



FIXING DRUM KIT
KIT DE FIJACIÓN PARA BIDÓN
KIT DE FIXATION POUR FÛT
FASSFIXIERUNGSKIT
KIT FIXADOR PARA TAMBOR

Parts and technical service guide
 Guía de servicio técnico y recambio
 Guide d'instructions et pièces de rechange
 Bedienungsanleitung und Teileliste
 Manual de Serviços Técnicos e Reposições

Part No. / Cód. / Réf. / Art. Nr. / Cód.:

741604 **741605** **741606**
741607 **741608**

Kits



FIG. 1



FIG. 2



- EN** Kit DPM-B. NC-741604. Grease service, drum 185 kg.
- ES** Kit DPM-B. NC-741604. Servicio grasa, bidón 185 kg.
- FR** Kit DPM-B. NC-741604. Distribution graisse, fût 185 kg.
- DE** Kit DPM-B. NC-741604. Fettservice, 185 kg Fass.
- PT** Kit DPM-B. NC-741604. Serviço de graxa, 185 kg tambor.



- EN** * Kit DPM-S. NC-741605. Grease service, drum 50 kg.
Kit DPM-B1. NC-741606. Grease service, drum 185 kg.

- ES** * Kit DPM-S. NC-741605. Servicio grasa, bidón 50 kg.
Kit DPM-B1. NC-741606. Servicio grasa, bidón 185 kg.

- FR** * Kit DPM-S. NC-741605. Distribution graisse, tonnelet 50 kg
Kit DPM-B1. NC-741606. Distribution graisse, fût 185 kg.

- DE** * Kit DPM-S. NC-741605. Fettservice, 50 kg Fass.
Kit DPM-B1. NC-741606. Fettservice, 185 kg Fass.

- PT** * Kit DPM-S. NC-741605. Serviço de graxa, 50 kg tambor.
Kit DPM-B1. NC-741606. Serviço de graxa, 185 kg tambor.



- EN** Kit DPM-B2. NC-741607. Oil service, drum 205 l.
Kit DPM-S1. NC-741608. Oil service, drum 60 l.

- ES** Kit DPM-B2. NC-741607. Servicio aceite, bidón 205 l.
Kit DPM-S1. NC-741608. Servicio aceite, bidón 60 l.

- FR** Kit DPM-B2. NC-741607. Distribution huile, fût 205 l.
Kit DPM-S1. NC-741608. Distribution huile, tonnelet 60 l.

- DE** Kit DPM-B2. NC-741607. Ölservice, 205 l Fass.
Kit DPM-S1. NC-741608. Ölservice, 60 l Fass.

- PT** Kit DPM-B2. NC-741607. Serviços de óleo, 205 l tambor.
Kit DPM-S1. NC-741608. Serviços de óleo, 60 l tambor.

Fixing drum / Fijación para bidón / Fixation pour fût / Fassfixierung / Fixador para tambor

**WARNING / ADVERTENCIA / AVERTISSEMENT /
WARNUNG / ADVERTÊNCIA**

EN

These operations must be performed with protective gloves and glasses. If you do not properly protect may cause a serious injury during handling.

ES

Estas operaciones deben realizarse con guantes y gafas. Si durante su manipulación no va correctamente equipado puede provocarle graves daños.

FR

Ces opérations doivent être effectuées avec des gants et des lunettes de protection. Si vous ne vous protégez pas correctement, vous courez un risque important de blessure grave lors de la manipulation.

DE

Diese Arbeitsgänge dürfen nur mit Schutzhandschuhen und Schutzbrille durchgeführt werden; andernfalls kann es während der Bearbeitung zu einer schwere Verletzung kommen.

PT

Estas operações devem ser realizadas com óculos de proteção e luvas. Se durante a manutenção do equipamento, acontecer alguma anomalia poderá provocar graves danos ao operador.

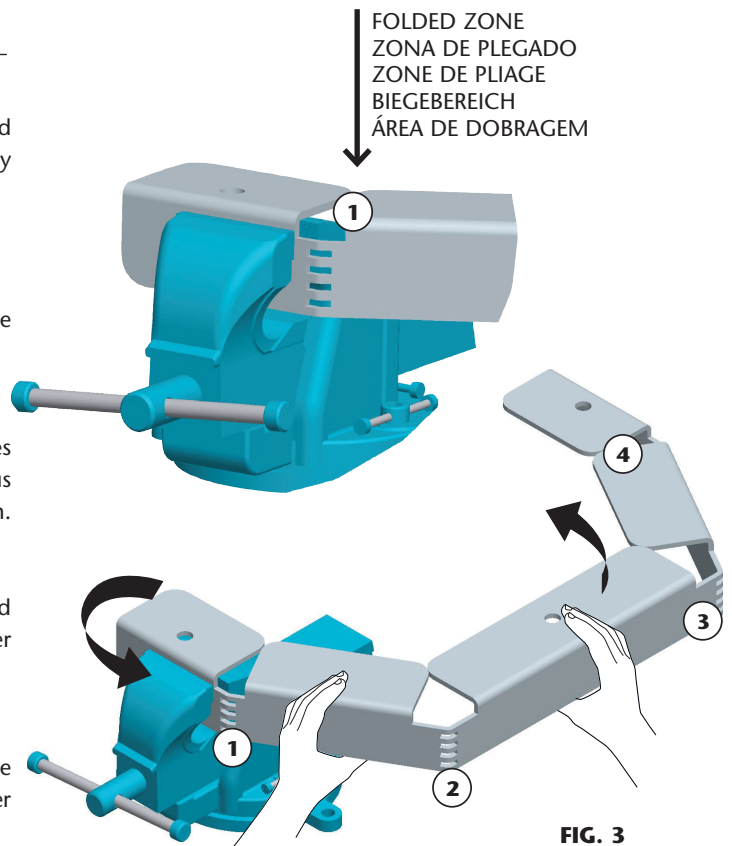

FIG. 3

**Dimensions of the fixing holes / Dimensiones de los agujeros de fijación /
Entraxes des trous de fixation / Maße der Fixierungsbohrungen / Dimensões dos furos para fixação**

WARNING / ADVERTENCIA / AVERTISSEMENT / WARNUNG / ADVERTÊNCIA

EN

If the structure is not properly anchored to the floor, could cause serious harm and accident.

* Dimensions of the fixing holes. For models (185 kg and 50 kg).

ES

Si la estructura no se ancla correctamente al suelo puede provocar graves daños personales o accidentes.

* Dimensiones de los agujeros de fijación de los dos modelos de perimetros (185 kg y 50 kg).

FR

Si la structure n'est pas correctement ancrée au sol, cela pourrait causer un préjudice grave ou un accident.

* Entraxes des trous de fixation des deux modèles (185 kg et 50 kg).

DE

Wenn die Halterung nicht sicher im Boden verankert ist, kann dies zu ernsthaften Verletzungen oder Unfällen führen.

* Maße der Fixierungsbohrungen der beiden Begrenzungsmodelle (185 kg und 50 kg).

PT

Se a estrutura não for fixada corretamente ao solo, poderá provocar graves acidentes, danificando o equipamento e danos aos usuários.

* Dimensões dos furos de fixação dos modelos em linha (185 Kg e 50 Kg).

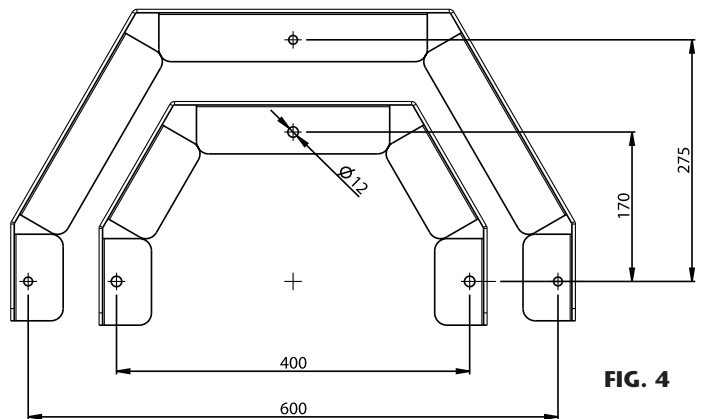

FIG. 4

2018.10.09-14:00