



www.larius.com

Zeus Liner

Street marking
with piston pump



IT https://www.larius.com/wp-content/uploads/ZEUS_LINER_ITA.pdf

EN https://www.larius.com/wp-content/uploads/ZEUS_LINER_UK.pdf

**This manual is to be considered as an English language translation of the original manual in Italian.
The manufacturer shall bear no responsibility for any damages or inconveniences that may arise due to
the incorrect translation of the instructions contained within the original manual in Italian.**

Due to a constant product improvement programme, the factory reserves the right to modify
technical details mentioned in this manual without prior notice.

ZEUS LINER

Street marking with piston pump

INDEX

A	WARNINGS	4
B	WORKING PRINCIPLE	5
C	TECHNICAL DATA.....	5
D	DESCRIPTION OF THE EQUIPMENT.....	5
E	TRANSPORT AND UNPACKING.....	6
F	CONDITIONS OF GUARANTEE.....	8
G	SAFETY RULES	10
H	TUBE CONNECTIONS	13
I	STARTING THE MOTOR	14
J	WASHING OF THE NEW EQUIPMENT	15
K	PRODUCT PREPARATION.....	17
L	REGULATIONS	18
M	WORKING	19
N	CLEANING AT THE END WORK.....	21
O	GENERAL MAINTENANCE.....	22
P	ROUTINE MAINTENANCE.....	22
Q	CORRECT PROCEDURE OF DECOMPRESSION	23
R	REPLACEMENT OF THE PUMPING GROUP'S GASKETS.....	24
S	PROBLEMS AND SOLUTIONS	30
	SPARE PARTS	
T	COMPLETE STEERING UNIT REF. 4555	33
U	COMPLETE FRAME UNIT REF. 4565 (REF. 4555 INCLUDED)	34
V	COMPLETE ZEUS LINER REF. 4554.....	36
W	COMPLETE 50L TANK REF. 4895.....	38
X	COMPLETE 20L TANK REF. 4890.....	39
Y	COMPLETE BOX REF. 4896	40
Z	COMPLETE BOX TRASFORMER REF. 4845.....	41
AA	COMPLETE MECHANICAL UNIT	42
AB	COMPLETE PUMPING UNIT	44
AC	FLOW COMPENSATOR.....	46
AD	RE-CIRCULATION UNIT COMPLETE REF. 4893	47
AE	GUNS ARM KIT REF. 26011	48
	CE DECLARATION OF CONFORMITY	49

**WE ADVISE THE USE OF THIS EQUIPMENT ONLY BY PROFESSIONAL OPERATORS.
 ONLY USE THIS MACHINE FOR USAGE SPECIFICALLY MENTIONED IN THIS MANUAL.**

Thank you for choosing a **SAMOA** product.
 As well as the product purchased, you will receive a range of support services
 enabling you to achieve the results desired, quickly and professionally.

A WARNINGS

The table below provides the meaning of the symbols used in this manual in relation to using, earthing, operating, maintaining, and repairing of this equipment.

	<ul style="list-style-type: none"> • Read this operator's manual carefully before using the equipment. • An improper use of this machine can cause injuries to people or things. • Do not use this machine when under the influence of drugs or alcohol. • Do not modify the equipment under any circumstances. • Use products and solvents that are compatible with the various parts of the equipment, and read the manufacturer's warnings carefully. • See the Technical Details for the equipment given in the Manual. • Check the equipment for worn parts once a day. If any worn parts are found, replace them using ONLY original spare parts. • Keep children and animals away from work area. • Comply with all safety standards.
	<ul style="list-style-type: none"> • It indicates an accident risk or serious damage to equipment if this warning is not followed.
   	<p>FIRE AND EXPLOSION HAZARD</p> <ul style="list-style-type: none"> • Solvent and paint fumes in work area can ignite or explode. • To help prevent fire and explosion: <ul style="list-style-type: none"> - Use equipment ONLY in well ventilated area. - Eliminate all ignition sources, such as pilot lights, cigarettes and plastic drop cloths (potential static arc). - Ground equipment and conductive objects. - Use only grounded hoses. - Do not use trichloroethane, methylene chloride, other halogenated hydrocarbon solvents or fluids containing such solvents in pressurized aluminium equipment. Such use can cause serious chemical reaction and equipment rupture, and result in death, serious injury, and property damage. - Do not form connections or switch light switches on or off if the air contains inflammable fumes. • If electrical shocks or discharges are encountered the operation being carried out using the equipment must be stopped immediately. • Keep a fire extinguisher at hand in the immediate vicinity of the work area.
	<ul style="list-style-type: none"> • It indicates wound and finger squashing risk due to movable parts in the equipment. • Tenersi lontano dalle parti in movimento. • Do not use the equipment without the proper protection. • Before any inspection or maintenance of the equipment, carry out the decompression procedure explained in this manual, and prevent any risk of the equipment starting unexpectedly.
 	<ul style="list-style-type: none"> • Report any risk of chemical reaction or explosion if this warning has not been given. • (IF PROVIDED) There is a risk of injury or serious lesion related to contact with the jet from the spray gun. If this should occur, IMMEDIATELY contact a doctor, indicating the type of product injected. • (IF PROVIDED) Do not spray before the guard has been placed over the nozzle and the trigger on the spray gun. • (IF PROVIDED) Do not put your fingers in the spray gun nozzle. • Once work has been completed, before carrying out any maintenance, complete the decompression procedure.
	<ul style="list-style-type: none"> • It indicates important recommendations about disposal and recycling process of products in accordance with the environmental regulations.
    	<ul style="list-style-type: none"> • Mark any clamps attached to earth cables. • Use ONLY 3-wire extension cords and grounded electrical outlets. • Before starting work make sure that the electrical system is grounded and that it complies with safety standards. • High-pressure fluid from gun, hose leaks, or ruptured components will pierce skin. • To help prevent injection, always: <ul style="list-style-type: none"> - (IF PROVIDED) Engage trigger lock when not spraying. - (IF PROVIDED) Do not put your hand over the spray tip. Do not stop or deflect leaks with your hand, body or other. - (IF PROVIDED) Do not point gun at anyone or at any part of the body. - (IF PROVIDED) Never spray without tip guard. - Do pressure relief if you stop spraying or being servicing sprayer and before any maintenance operations. - Do not use components rated less than sprayer Maximum Working Pressure. - Never allow children to use this unit - (IF PROVIDED) Brace yourself; gun may recoil when triggered. • If high pressure fluid pierces your skin, the injury might look like "just a cut", but it is a serious wound! Get immediate medical attention.
   	<ul style="list-style-type: none"> • It is obligatory to wear suitable clothing as gloves, goggles and face shield. • Wear clothing that complies with the safety standards in force in the country in which the equipment is used. • Do not wear bracelets, earrings, rings, chains, or anything else that may hinder the operator's work. • Do not wear clothing with wide sleeves, scarves, ties, or any other piece of clothing that could get tangled up in moving parts of the equipment during the work, inspection, or maintenance cycles.

B TRANSPORT AND UNPACKING

- The packed parts should be handled as indicated in the symbols and markings on the outside of the packing.
- Before installing the equipment, ensure that the area to be used is large enough for such purposes, is properly lit and has a clean, smooth floor surface.
- The manufacturer will not be responsible for the unloading operations and transport to the workplace of the machine.
- Check the packing is undamaged on receipt of the equipment. Unpack the machine and verify if there has been any damage due to transportation.

In case of damage, call immediately the manufacturer and the Shipping Agent. All the notices about possible damage or anomalies must arrive timely within 8 days at least from the date of receipt of the plant through Registered Letter to the Shipping Agent and to the manufacturer.

- The user is responsible for the operations of unloading and handling and should use the maximum care so as not to damage the individual parts or injure anyone. To perform the unloading operation, use only qualified and trained personnel (truck and crane operators, etc.) and also suitable hoisting equipment for the weight of the installation or its parts.

Follow carefully all the safety rules.

The personnel must be equipped with the necessary safety clothing.



The disposal of packaging materials is a customer's competence and must be performed in accordance with the regulations in force in the country where the plant is installed and used. It is nevertheless sound practice to recycle packaging materials in an environment-friendly manner as much as possible.

C CONDITIONS OF GUARANTEE



The conditions of guarantee do not apply in the following situations:

- improper washing and cleaning of components causing malfunction, wear or damage to the equipment or any of its parts;
- improper use of the equipment;
- use that does not conform with applicable national legislation;
- incorrect or faulty installation;
- modifications, interventions and maintenance that have not been authorised by the manufacturer;
- use of non-original spare parts or parts that do not correspond to the specific model;
- total or partial non-compliance with the instructions provided.

D SAFETY RULES

- THE EMPLOYER SHALL TRAIN ITS EMPLOYEES ABOUT ALL THOSE RISKS STEMMING FROM ACCIDENTS, ABOUT THE USE OF SAFETY DEVICES FOR THEIR OWN SAFETY AND ABOUT THE GENERAL RULES FOR ACCIDENT PREVENTION IN COMPLIANCE WITH INTERNATIONAL REGULATIONS AND WITH THE LAWS OF THE COUNTRY WHERE THE PLANT IS USED.
- THE BEHAVIOUR OF THE EMPLOYEES SHALL STRICTLY COMPLY WITH THE ACCIDENT PREVENTION AND ALSO ENVIRONMENTAL REGULATIONS IN FORCE IN THE COUNTRY WHERE THE PLANT IS INSTALLED AND USED.

Read carefully and entirely the following instructions before using the product. Please save these instructions in a safe place.



The unauthorised tampering/replacement of one or more parts composing the machine, the use of accessories, tools, expendable materials other than those recommended by the manufacturer can be a danger of accident. The manufacturer will be relieved from tort and criminal liability.

- KEEP YOUR WORK PLACE CLEAN AND TIDY. DISORDER WHERE YOU ARE WORKING CREATES A POTENTIAL RISK OF ACCIDENTS.
- ALWAYS KEEP PROPER BALANCE AVOIDING UNUSUAL STANCE.
- BEFORE USING THE TOOL, ENSURE THERE ARE NOT DAMAGED PARTS AND THE MACHINE CAN WORK PROPERLY.
- ALWAYS FOLLOW THE INSTRUCTIONS ABOUT SAFETY AND THE REGULATIONS IN FORCE.
- KEEP THOSE WHO ARE NOT RESPONSIBLE FOR THE EQUIPMENT OUT OF THE WORK AREA.
- **NEVER** EXCEED THE MAXIMUM WORKING PRESSURE INDICATED.
- **NEVER** POINT THE SPRAY GUN AT YOURSELVES OR AT OTHER PEOPLE. THE CONTACT WITH THE CASTING CAN CAUSE SERIOUS INJURIES. IN CASE OF INJURIES CAUSED BY THE GUN CASTING, SEEK IMMEDIATE MEDICAL ADVICE SPECIFYING THE TYPE OF THE PRODUCT INJECTED. NEVER UNDERVALUE A WOUND CAUSED BY THE INJECTION OF A FLUID.
- ALWAYS DISCONNECT THE SUPPLY AND RELEASE THE PRESSURE IN THE CIRCUIT BEFORE PERFORMING ANY CHECK OR PART REPLACEMENT OF THE EQUIPMENT.
- **NEVER** MODIFY ANY PART IN THE EQUIPMENT. CHECK REGULARLY THE COMPONENTS OF THE SYSTEM. REPLACE THE PARTS DAMAGED OR WORN.
- TIGHTEN AND CHECK ALL THE FITTINGS FOR CONNECTION BETWEEN PUMP, FLEXIBLE HOSE AND SPRAY GUN BEFORE USING THE EQUIPMENT.

- ALWAYS USE THE FLEXIBLE HOSE SUPPLIED WITH STANDARD KIT. THE USE OF ANY ACCESSORIES OR TOOLING OTHER THAN THOSE RECOMMENDED IN THIS MANUAL, MAY CAUSE DAMAGE OR INJURE THE OPERATOR.
- THE FLUID CONTAINED IN THE FLEXIBLE HOSE CAN BE VERY DANGEROUS. HANDLE THE FLEXIBLE HOSE CAREFULLY. DO NOT PULL THE FLEXIBLE HOSE TO MOVE THE EQUIPMENT. NEVER USE A DAMAGED OR A REPAIRED FLEXIBLE HOSE.
- NEVER SPRAY OVER FLAMMABLE PRODUCTS OR SOLVENTS IN CLOSED PLACES.
- NEVER USE THE TOOLING IN PRESENCE OF POTENTIALLY EXPLOSIVE GAS.

The high speed of travel of the product in the hose can create static electricity through discharges and sparks.

It is suggested to earth the equipment. The gun is earthed through the high pressure flexible hose.

All the conductors near the work area must be earthed.

Always check the product is compatible with the materials composing the equipment (*pump, spray gun, flexible hose and accessories*) with which it can come into contact.

Never use paints or solvents containing halogen hydrocarbons (as the methylene chloride).

If these products come into contact with aluminium parts can provoke dangerous chemical reactions with risk of corrosion and explosion.

If the product to be used is toxic, avoid inhalation and contact by using protection gloves, goggles and proper face shields.

Take proper safety measures for the protection of hearing in case of work near the plant.

E WORKING PRINCIPLE

The **ZEUS LINER** unit is defined “piston pump”. An piston pump is used for high pressure painting without air (from this process derives the term “airless”). The internal combustion engine, mounted upon the undercarriage, powers the alternative piston pump. A cam shaft and a connecting rod allow to obtain the reciprocating motion necessary to the working of the “pumping group” piston. The piston movement produces a “vacuum”. The product is sucked, pushed towards the pump outlet and then sent to the gun through the flexible hose. A electronic device, allows to adjust and control the pressure of the material coming out of the pump. A safety valve avoiding overpressure, guarantees the total reliability of the equipment.

The control zone allows for the possibility of:

- Activating the dispensing spray gun;
- Enabling or disabling the frontal steering wheel;
- Adjust the pressure of work;

This type of equipment is capable of painting one line at a time in a single color. The line can be either solid or dotted, based on the working requirements.

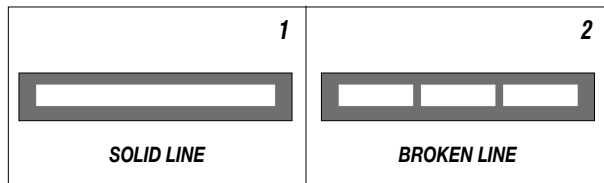

ZEUS LINER is ideal for medium marking and maintenance jobs.

Use water or non-refractive solvent filtered paint specifically designed for airless application.

ZEUS LINER allows for the marking and maintaining of all types lines on highways, freeways, pedestrian crossings, parking lots and squares, as well as every horizontal marking required by the highway code. Airless marking has numerous proven benefits with respect to line-markers with pressurised tanks, which have been rendered obsolete by airless-technology line markers.

Airless line-marking guarantees:

- Decreased Environmental Impact;
- Decreased drying time.

The paint dries quickly and the line is defined in a uniform manner with a single coat. The airless function requires the use of filtered paint which is specifically designed for airless application. This means that the paint is homogeneous, of a smooth and uniform consistency and will not form crusts, nor will it become gelatinous or thick. With this airless line-marker, the paint adheres firmly to all types of pavement, with optimal visibility, and is resistance to wear caused both by traffic as well as atmospheric agents.



Fig. 1

In this liner model, the paint canister can be loaded directly upon the undercarriage or else poured into the non-stick (20 l or 50 l, depending on the model). In every case, cleaning, maintenance and colour change operations are facilitated.

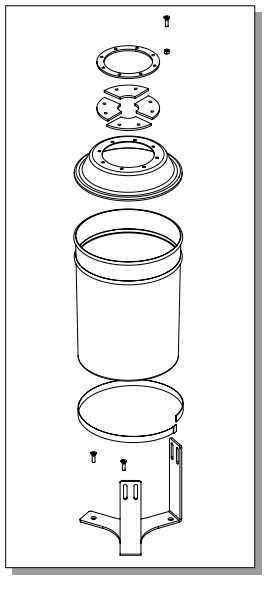

Fig. 4 - Versione 20L



Fig. 2

The line-marker is equipped with pivoting frontal wheel which even increases the agility of the larger models. High yield, high efficiency, high versatility.

This line-marker utilises non-premixed paints. This allows it to achieve about 30 % more yield with respect to standard line-markers. Every model is also an airless spray gun which can be used in the construction/decoration sector together with washable products, enamels, breathable paints and flooring resins.

A vast assortment of accessories is available to satisfy every customer demand.



Fig. 3 - Versione 50L



Fig. 5

F TECHNICAL DATA

ZEUS LINER	
Max. pressure	210 bar
Max. flow rate	4 - l/m
Motor power	4,8 HP
Airless paint capacity	23lt paint can - 50 lt gravity tank
Dimensions	1.105 x 1.700 x 850 mm
Weight	150 Kg

SECTORS OF USE

- External or underground parking lots (schools, hotels, airports, supermarkets, train stations, subway stations, ports);
- External public areas;
- Industrial and exhibition building zones;
- Freeway service areas and service stations;
- Pedestrian median lines, intersections, bicycle tracks, reserved lanes;
- Internal and external logistic area markings;
- Playing fields.



SFC - TSC SPRAY TIPS/NOZZLES TABLE

Ø nozzle (inch)	Spray angle (°)	Line Width		Flow rate (gpm)	Flow rate (lpm)
		inch	mm		
.013	13 - 20	2 - 4	51 - 102	.18	.69
.015	15 - 20	2 - 4	51 - 102	.24	.91
	15 - 30	4 - 6	102 - 152		
.017	17 - 20	2 - 4	51 - 102	.31	1.17
	17 - 30	4 - 6	102 - 152		
	17 - 40	4 - 8	102 - 204		
.019	19 - 20	2 - 4	51 - 102	.38	1.47
	19 - 30	4 - 6	102 - 152		
	19 - 40	4 - 8	102 - 204		
.021	21 - 30	4 - 6	102 - 152	.47	1.79
	21 - 40	4 - 8	102 - 204		
	21 - 60	8 - 12	204 - 305		
.023	23 - 30	4 - 6	102 - 152	.57	2.15
	23 - 40	4 - 8	102 - 204		
	23 - 60	8 - 12	204 - 305		
.025	25 - 30	4 - 6	102 - 152	.67	2.54
	25 - 40	4 - 8	102 - 204		
	25 - 60	8 - 12	204 - 305		
.027	27 - 30	4 - 6	102 - 152	.77	2.96
	27 - 40	4 - 8	102 - 204		
	27 - 60	8 - 12	204 - 305		

Ø nozzle (inch)	Spray angle (°)	Line Width		Flow rate (gpm)	Flow rate (lpm)
		inch	mm		
.029	29 - 30	4 - 6	102 - 152	.90	3.42
	29 - 40	4 - 8	102 - 204		
	29 - 60	8 - 12	204 - 305		
.031	31 - 30	4 - 6	102 - 152	1.03	3.90
	31 - 40	4 - 8	102 - 204		
	31 - 60	8 - 12	204 - 305		
.033	33 - 30	4 - 6	102 - 152	1.17	4.42
	35 - 30	4 - 6	102 - 152		
.035	35 - 40	4 - 8	102 - 204	1.31	4.98
	35 - 60	8 - 12	204 - 305		
	39 - 30	4 - 6	102 - 152		
.039	39 - 40	4 - 8	102 - 204	1.63	6.18
	39 - 60	8 - 12	204 - 305		
	43 - 30	4 - 6	102 - 152		
.043	43 - 40	4 - 8	102 - 204	1.98	7.51
	43 - 60	8 - 12	204 - 305		

Code	Manual push	23 lt paint can	50 lt gravity tank	Airless hose	AT250 Airless manual gun	Airless nozzle holder	Super Fast Clean airless nozzles
4561	•	•	–	N°1 Cod. 35015 Ø 1/4"-M16x1,5-10m	N°1 Cod. 11210 M16x1,5 inlet swivel	N°1 Cod. 18270	N°1 SFC 11-40 N°1 SFC 13-40 N°1 SFC 15-40
4560	•	–	•	N°1 Cod. 35015 Ø 1/4"-M16x1,5-10m	N°1 Cod. 11210 M16x1,5 inlet swivel	N°1 Cod. 18270	N°1 SFC 11-40 N°1 SFC 13-40 N°1 SFC 15-40

CONFIGURATIONS		
Part No.	4561	4560
Petrol engine power	4,8 HP	4,8 HP
Max. Flow rate	4 l/m	4 l/m
Max. Pressure	220 bar	220 bar
Manual push	•	•
Self propelled	–	–
Head control system	–	–
Automatic marking lines kit	–	–
Glass beads kit	–	–
Flashing telescopic rod kit	–	–
Working light kit	–	–
Operator footboard kit	–	–
Piston type accumulator	–	–
23 L Paint can	•	–
50 L Gravity tank	–	•

CONFIGURATIONS		
Part No.	4561	4560
Airless hose Ø 1/4" - M16 x 1,5 - 10M	•	•
Airless hose Ø 1/4" - M16 x 1,5 - 15M	–	–
Recirculation Hose	•	•
Filter with pressure gauge	•	•
1 AT250 Airless manual spray gun	•	•
2 AT250 Airless manual spray guns	–	–
2 LA96 Airless manual spray guns	–	–
Airless nozzle holder	•	•
Super fast clean airless spraying nozzles	•	•
1 colour	•	•
1 single line: continuous - dashed	•	•
2 double line: continuous - dashed -mixed	–	–
Tools kit	•	•

ACCESSORIES	
Part No.	Description
35015	Airless hose Ø 1/4" - M16 x 1,5 - 10 m
11200	AT250 manual airless spray gun - M16x1,5 inlet swivel+ Nozzle holder
11210	AT250 manual airless spray gun - M16x1,5 inlet swivel
18270	Airless nozzle holder
SFC	Super Fast Clean airless nozzle. Size from 11-20 to 51-80
TSC	Super Fast Clean airless nozzle. Size from 7-20 to 31-60
18240	50 l Gravity tank
18245	50 l Gravity tank + Cover
18241	50 l Gravity tank + Cover + Basket
4500	11 l Gravity tank + Glass beads diffuser hose

KITS	
Part No.	Description
4307/1	Mounting kit for second airless gun (airless gun not included)
18359	11 l Gravity tank + 1 Diffuser hose + 1 Glass beads manual spray gun kit
18354	11 l Gravity tank + 1 Diffuser hose + 2 Glass beads manual spray guns kit
4038	Laser pointer kit
4840	Gun handling + Front pivot wheel kit (manual push airless line strippers models)

G DESCRIPTION OF THE EQUIPMENT

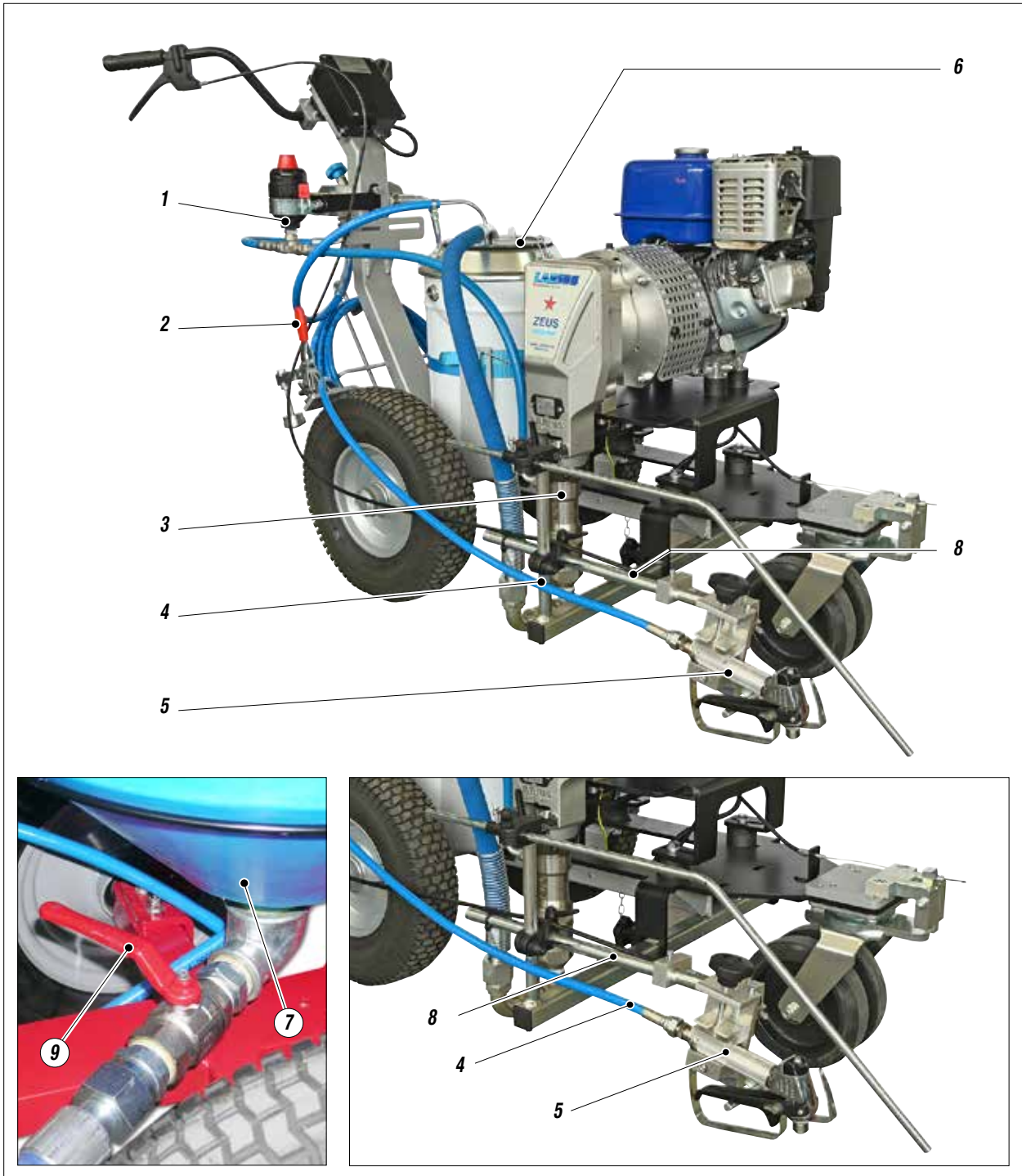

Fig. 1

Pos.	Description
1	Flow compensator
2	Brake
3	Pumping group
4	Product supply tube
5	Gun AT250

Pos.	Description
6	lt. 20 tank
7	lt. 50 tank
8	Gun-holder arm
9	Suction intake valve (lt. 50 tank version)



Fig. 1

Pos.	Description
10	Draught hose (ft. 20 tank version)
11	Recirculation tube (ft. 20 tank version)
12	Recirculation lines (ft. 50 tank version)

Pos.	Description
13	Gasoline tank
14	Pivoting wheel

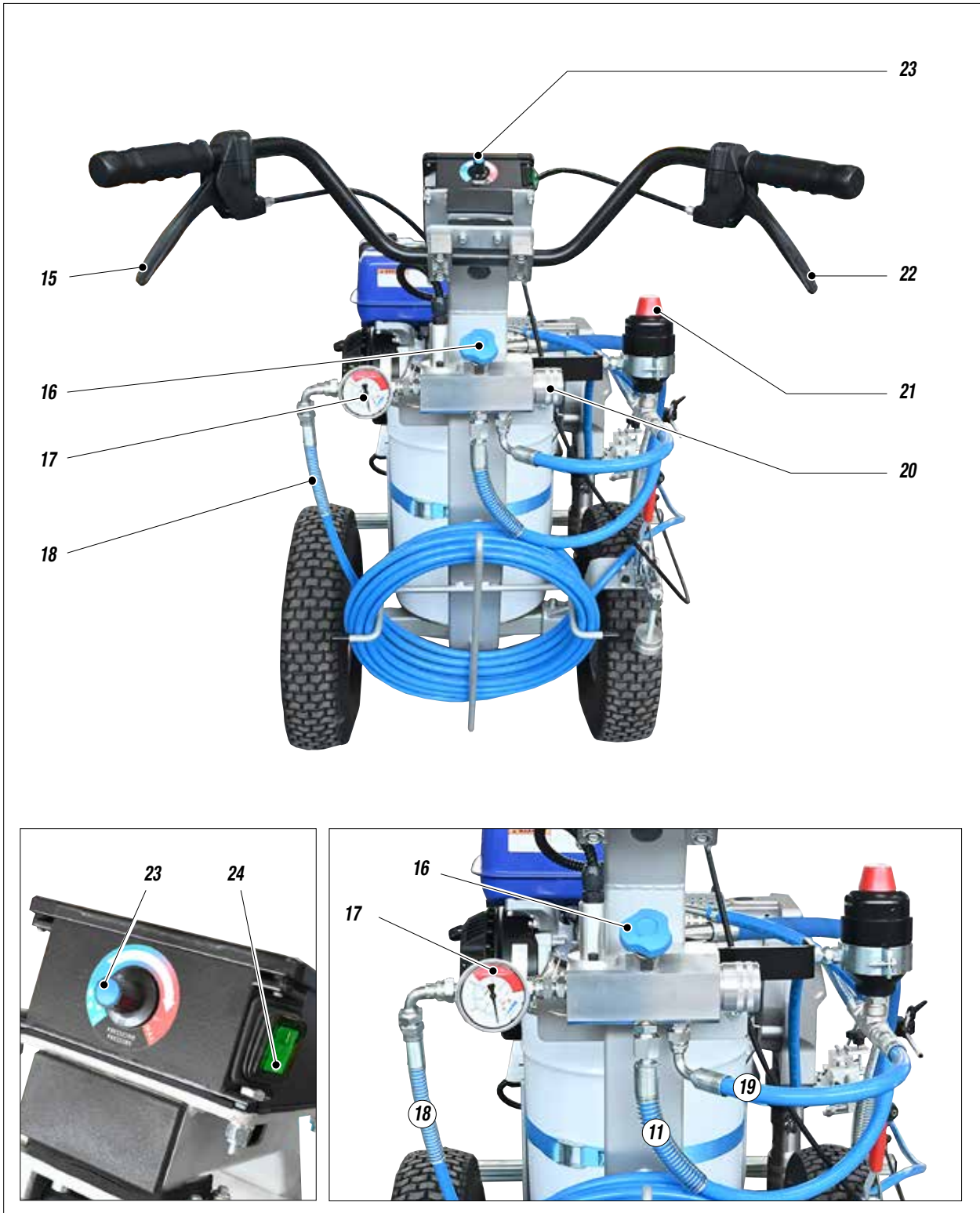

Fig. 1

Pos.	Description
15	Directional wheel lock/release lever
16	Safety-recirculation valve
17	Manometer
18	Gun connection lines
19	Pumping unit connection lines

Pos.	Description
20	Plug for filter
21	Compensation valve
22	Gun operating lever
23	Potentiometer for adjusting the operating pressure
24	ON/OFF switch

H TUBE CONNECTIONS

Flexible re-circulation tube connection

- Connect the flexible re-circulation tube (1) to the connector (2) ensuring to tighten the fittings (*the use of two wrenches is suggested*).

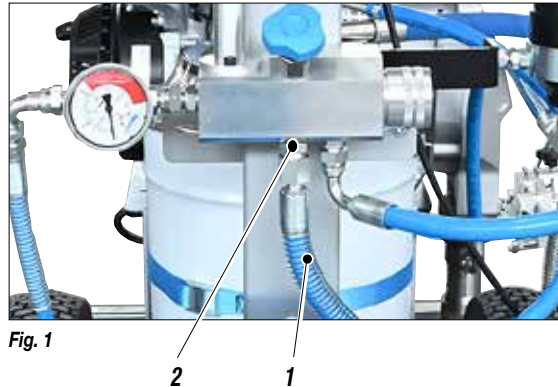

Pump unit flexible tube connection

- Connect the pump unit's flexible tube (3) to the connector (4) of the compensation valve and then to the connector (5) of the pumping unit, taking care to tighten the fittings well (*we recommend using two wrenches*).

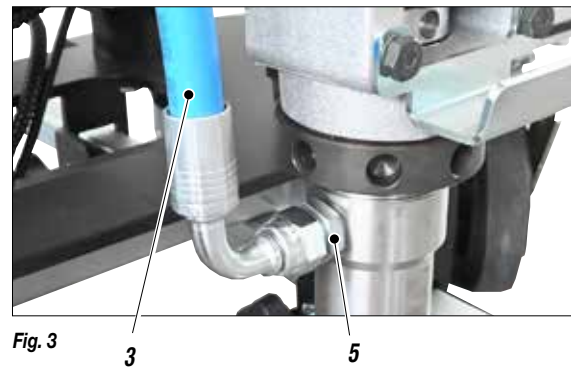

Hose connection to the flow compensator

- Connect the hose (6) between the flow compensator (7) to the recirculation group (8) (*the use of two wrenches is suggested*).

Flexible tube and spray gun connection

- Connect the flexible tube (9) to the connector (10) ensuring to tighten the fittings (*the use of two wrenches is suggested*).

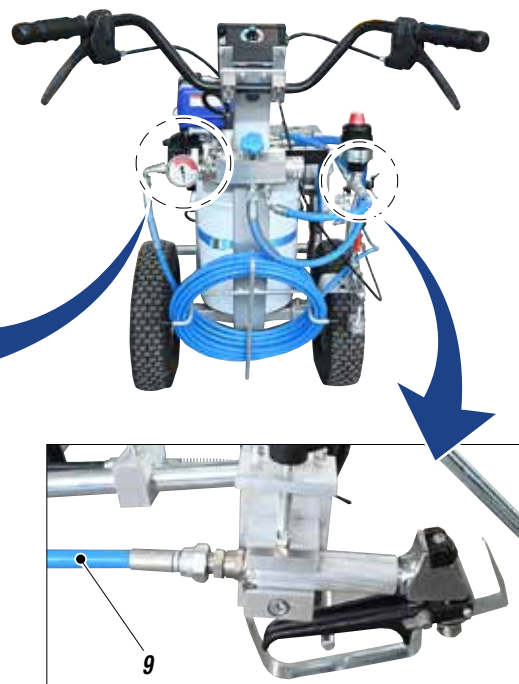

Fig. 5

- It is recommended to use the hose provided with the standard kit.
NEVER use a damaged or a repaired flexible hose.
NEVER use sealants on fittings' threads.

I STARTING THE MOTOR

In order to start the motor, proceed as follows:

1

- Fill the gasoline tank (1).

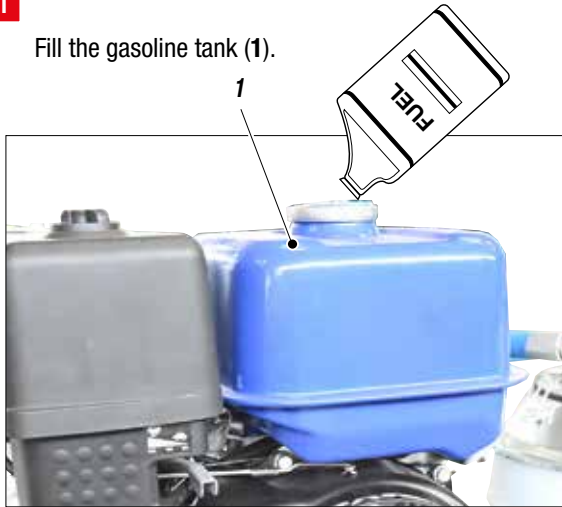

Fig. 1

2

- Open the fuel tap (2) and position it to "OPEN" (I).



Fig. 2

3

- Position lever (3) for first start-up cold ("START" position).



Fig. 3

4

- Press the switch (4) to ON (I).



Fig. 4

5

- Bring the accelerator lever (5) to about 1/2 of its run.

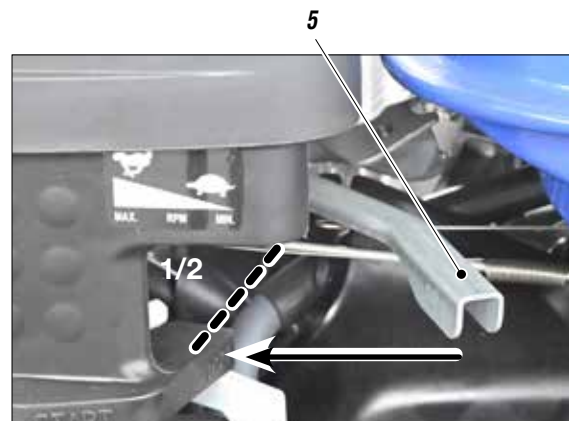

Fig. 5

6

- Pull the rope to start (6).

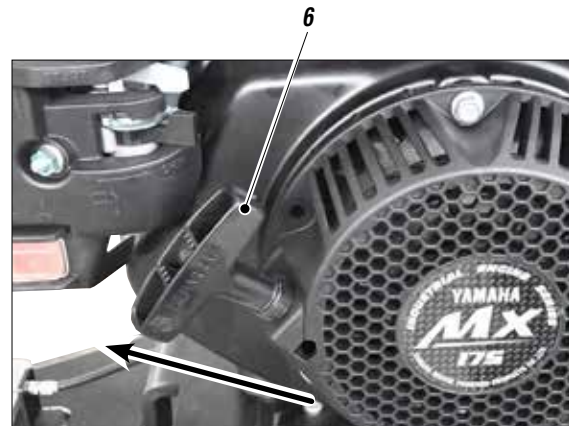

Fig. 6

J WASHING OF THE NEW EQUIPMENT

- The equipment has already been adjusted at our factory with light mineral oil left inside the pumping group as protection. Therefore, wash with diluent before sucking the product.
- Lift the suction pipe and dip it into the solvent tank.
- Clean the inside of the tank with a brush.
- Ensure the gun (1) is without nozzle.
- Start the motor following the indications provided in the chapter “STARTING THE MOTOR”.
- Press the switch (3) of the equipment “ON” (I).

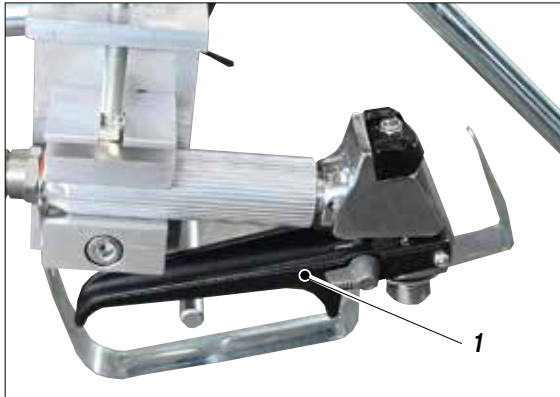

Fig. 1

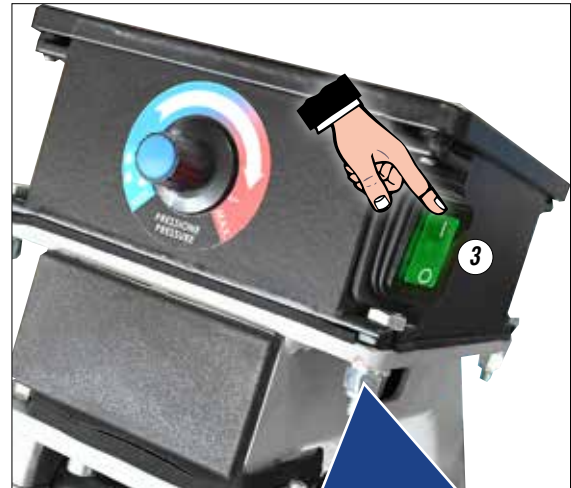
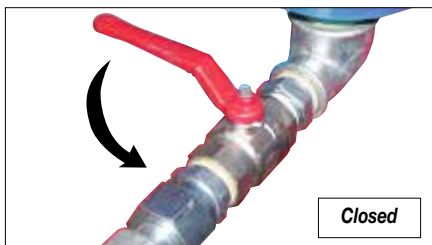
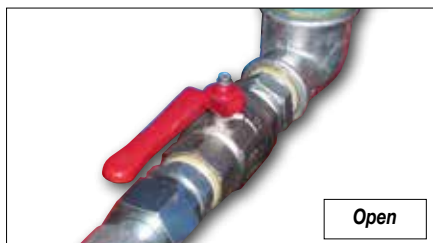

Fig. 3

- Open the product output tap (2). (It. 50 tank version)



Closed



Open

Fig. 2



- Open the recirculating-safety valve (4).

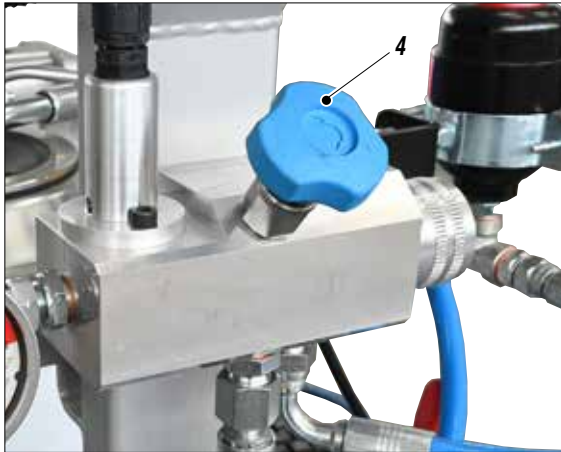

Fig.4

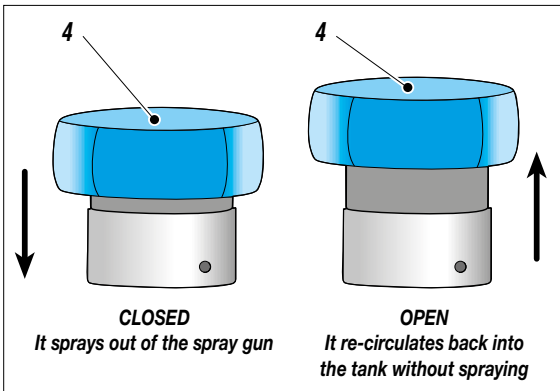

Fig. 5

- Turn the pressure setting knob (5) clockwise to the “CIRCULATION & WASHING” position (drop symbol).

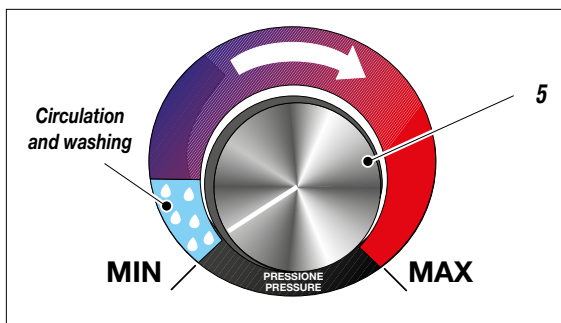

Fig. 6

- Visually check that the wash fluid starts to re-circulate within the tank (6).

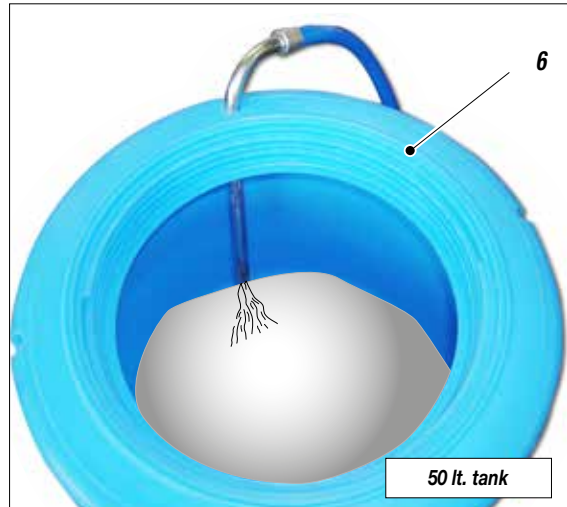

Fig.7



Fig.8

- Turn the pressure adjustment handle (5) clockwise to stop the pump.
- Closed the recirculating-safety valve (4).



Fig. 9

- Turn pressure regulating knob (5) clockwise a little so that the machine idles.

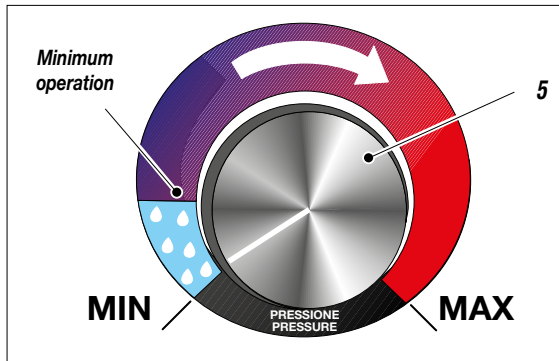

Fig. 9

- Remove the gun (7) from its support and point it into a container (8). Hold the trigger down (to perform the cleaning) until clean solvent comes out, or else until all of the wash fluid has been expelled from the tank.

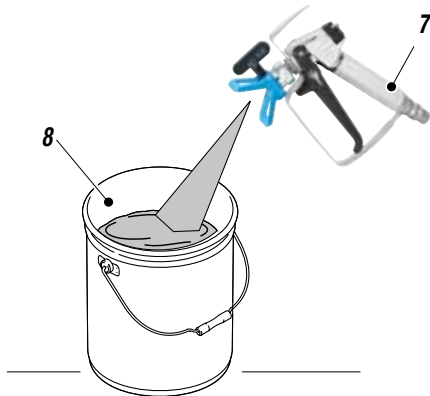

Fig. 10



Repeat the same operations with clean solvent if necessary.

- After having completed the wash operations, bring the handle to its "MIN" position (5) and point the gun (7) into a collection container (8) and press the trigger to release the residual pressure. Release the trigger when finished.



Absolutely avoid to spray solvents indoors. In addition, it is recommended to keep away from the pump in order to avoid the contact between the solvent fumes and the motor.

- Shut off the equipment by turning the switch to its **OFF** position "(0)".
- Stop the combustion engine.
- At this point the machine is ready. If water-based paints are to be used, after the wash with solvent wash the tank again with soap and water, then rinse with clean water (repeating the previously described procedures).
- Insert the manual gun trigger lock and assemble the nozzle.

K PRODUCT PREPARATION



MAKE SURE THE PRODUCT IS SUITABLE TO BE USED WITH A SPRAY GUN.

- Mix and filter the product before using it. For filtration use **CLOSE-MESH** and **LARGE-MESH LARIUS METEX** braids.



Make sure the product to be used is compatible with the materials employed for manufacturing the equipment (stainless steel and aluminium). Because of that, please contact the supplier of the product.

Never use products containing halogen hydrocarbons (as *methylene chloride*). If these products come into contact with aluminium parts of the equipment, can provoke dangerous chemical reactions with risk of explosion.

- Fill the tank (1) with the paint.



Fig.1



Fig.2

L REGULATIONS

ADJUSTING THE GUN POSITION

In order to adjust the position of the spray gun (1) use the knobs (2-3).

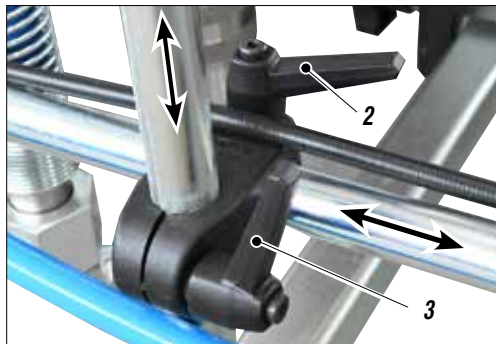
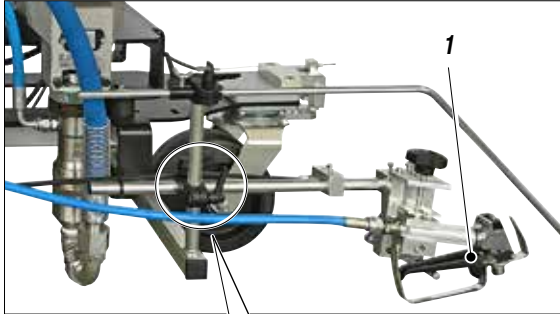
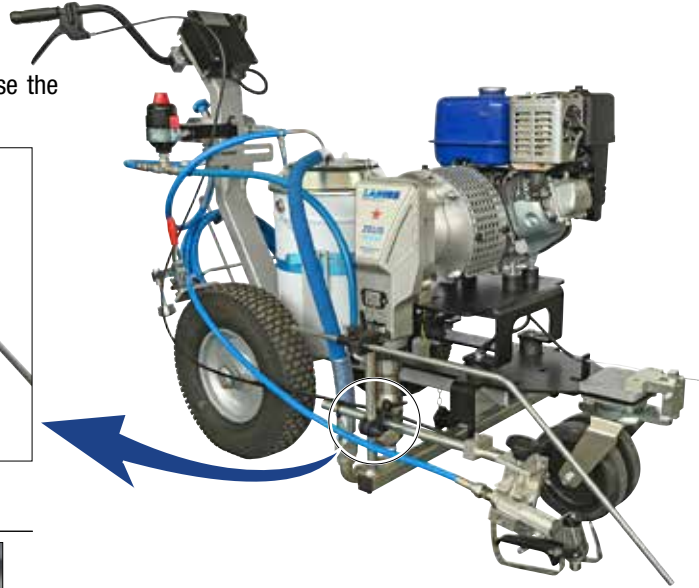

Fig. 1



ADJUSTING THE GUIDE ROD

In order to adjust the position of the guide rod (4) use the knobs (5-6).

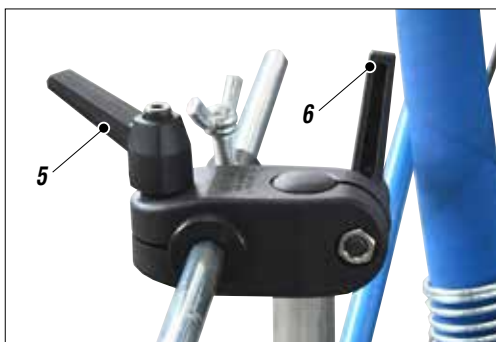
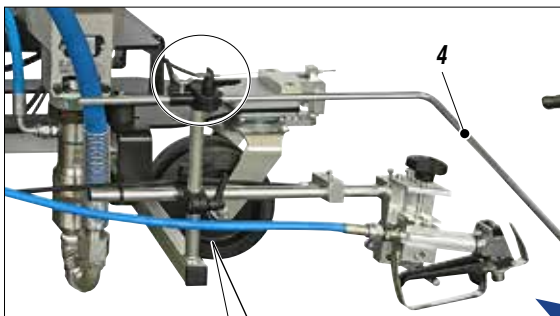
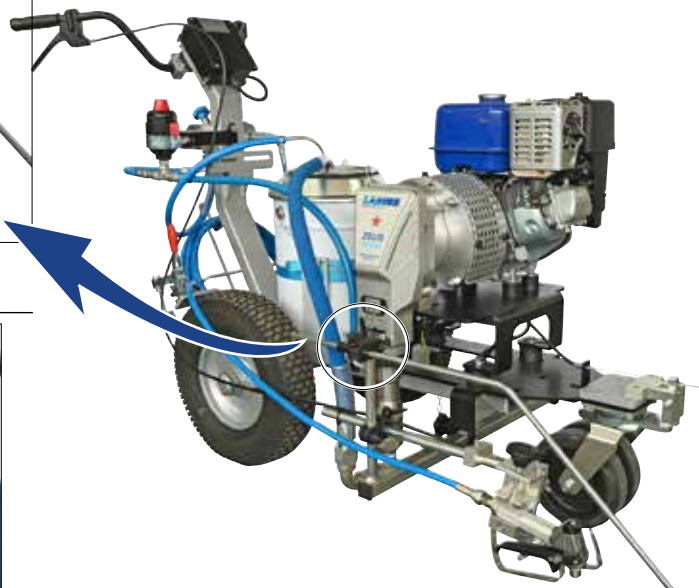

Fig. 2



ADJUSTING THE GUN SUPPORT ARM

In order to adjust the position of the spray gun support arm (7) use the knobs (8-9).

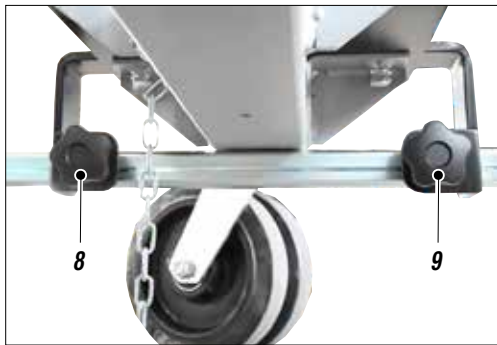
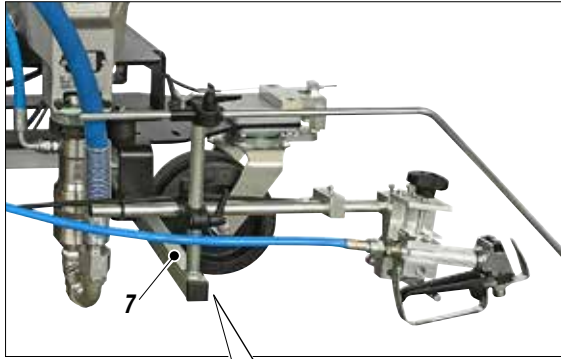
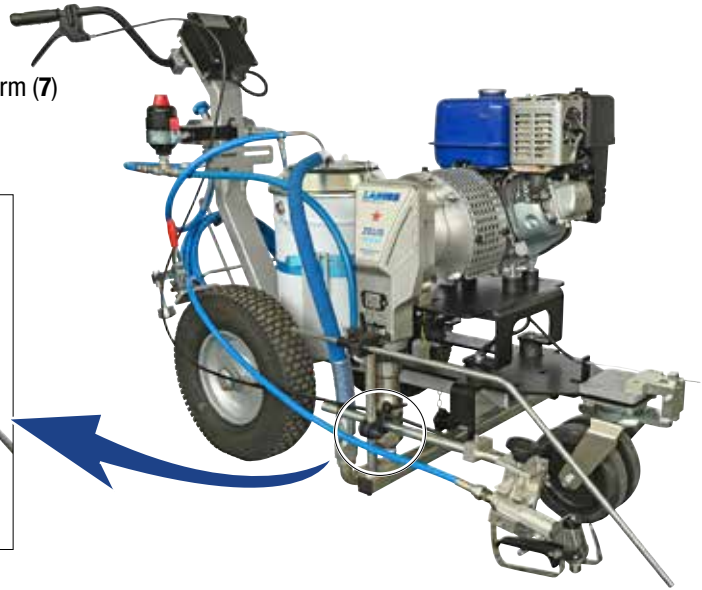

Fig. 3



M WORKING

SETUP PROCEDURE

- Use the tooling after performing all the **SETTING UP** operations above described.
- Check that there is enough petrol.
- Open the product output tap (1) (*lt. 50 tank version*).

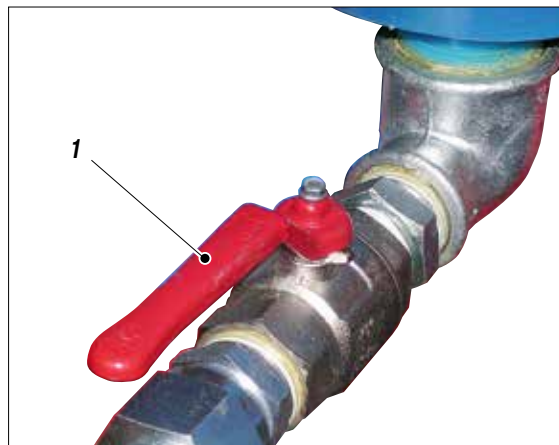

Fig. 1

- Start the motor following the indications provided in the chapter “**STARTING THE MOTOR**”.
- Make sure that the re-circulation/safety valve (2) is closed (*spray enabled*).

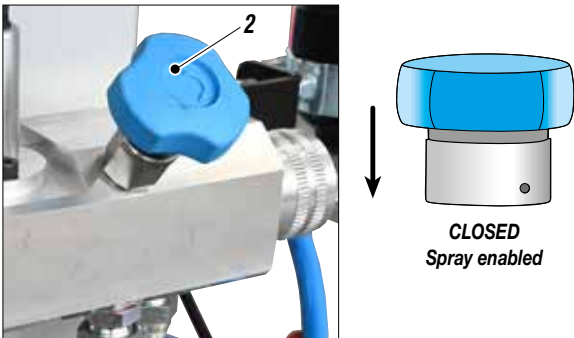

Fig. 2

- Press the switch (3) of the equipment “ON” (I).
- Turn the pressure adjustment handle clockwise until the desired setting has been reached.



Fig. 3

ADJUSTING PUMP UNIT SPEED

- Move the motor acceleration lever (4) gently to increase or decrease the speed of the pump.

During the painting operation it is normally recommended to maintain the position of the accelerator lever (4) at about 3/4 of its maximum run.

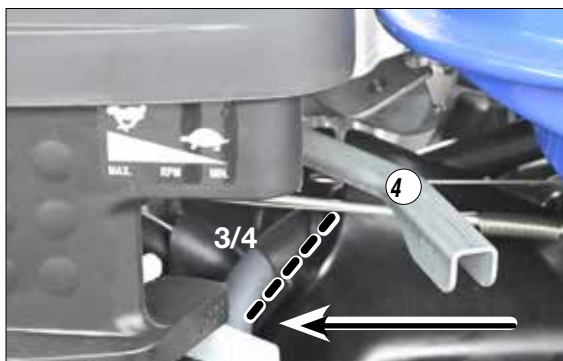

Fig. 4

SPRAY ADJUSTMENT

- Slowly turn clockwise the pressure control knob to reach the pressure value in order to ensure a good atomization of the product.
- An irregular and marked spray on the sides indicates a low working pressure. On the contrary, a too high pressure causes a high fog (“overspray”) and waste of product.
- Pull the lever on the right (5) to activate the spray gun and begin working, advancing the machine in a continuous manner.



Fig. 5



NEVER point the spray gun at yourselves or at other people. The contact with the casting can cause serious injuries. In case of injuries caused by the gun casting, seek immediate medical advice specifying the type of the product injected.



Recirculating-safety valve: when working at the maximum pressure available, releasing the gun trigger sudden increases of pressure can occur. In this case, the recirculating-safety valve opens automatically eliminating part of the product from the recirculating tube. Then it closes so as to go back to the first working conditions.

N CLEANING AT THE END WORK

- Reduce pressure to the minimum (turn the pressure control knob (1) counterclockwise).



Fig. 1

- Release the residual pressure by holding down the trigger of the gun and pointing it into a container.
- Eliminate the paint remaining within the tank (2) by placing the re-circulation tube (3) into a container.
- Open the recirculating-safety valve (4).

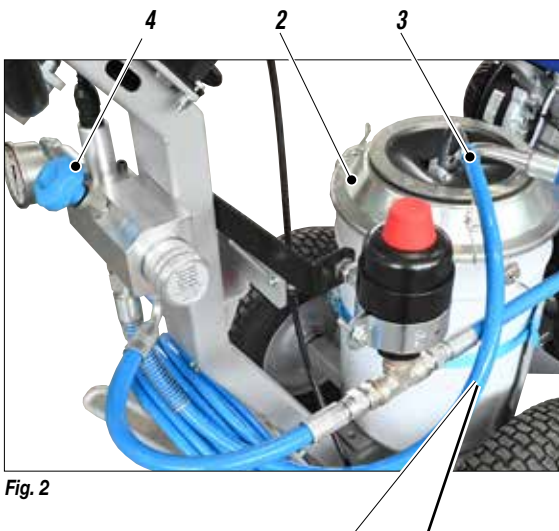
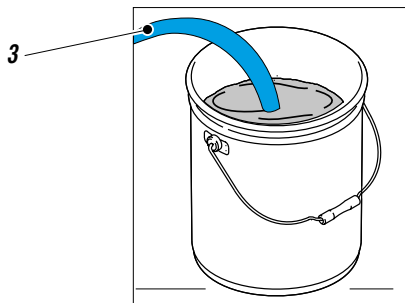

Fig. 2



- Turn the pressure adjustment (1) handle slightly clockwise to make the machine function at minimum pressure (pump activated), until the tank has been completely emptied then shut off the pump by bringing the handle (1) to its minimum position.

- Fill the tank (2) with wash fluid.
- Clean the walls of the tank with a brush.
- Turn the pressure adjustment (1) handle slightly clockwise to make the machine function at minimum pressure (pump activated).
- Make sure the re-circulation tube (3) is inserted into a container and wait for clean wash fluid to come out of it.
- Turn the pressure adjustment handle (1) to minimum (pump stopped).
- Place the re-circulation tube back into the tank.
- Keep the gun's trigger pressed to release any residual pressure.
- Remove the nozzle from the gun and wash it separately.
- Closed the recirculating-safety valve
- Turn the pressure adjustment handle (1) slightly clockwise to make the machine function at minimum pressure (pump activated).
- Point the manual gun (5) into a container (6), drain the residual paint and wait for the wash fluid to come out clean the entire spraying circuit.

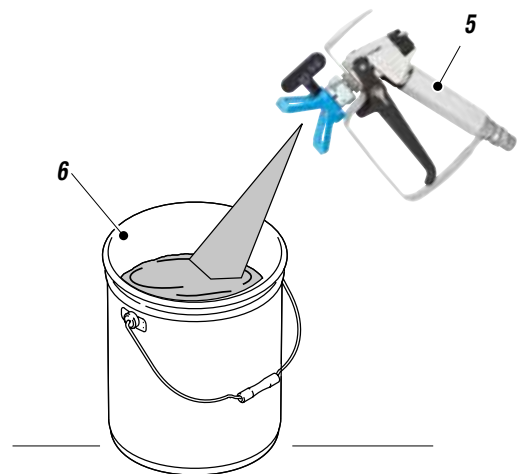

Fig. 3

- Empty all of the wash fluid from the tank and turn off the equipment.
- Turn the pressure adjustment handle (1) to minimum (pump stopped).
- Shut off the motor.
- In case of long storage, we recommend you to suck and to leave light mineral oil inside the pumping group and the flexible hose.



Follow the washing procedure before using again the equipment.

O GENERAL MAINTENANCE



Discharge the pressure in the pump unit (*open the discharge valve*) before carrying out any maintenance.

DAILY

- Clean the filters;
- Clean the nozzles;
- Clean all the varnish circuit with a specific product;
- Check the fuel motor (*see the maintenance table*).

PERIODICALLY

- Check the pumping gaskets draft (*if the product draws, replace gaskets*);
- Clean the mobile parts from the varnish deposits (*spray guns, etc.*);
- Check the gun cables tightening, the wheel block;
- Check that the tubes and all the fittings are correctly locked.

P ROUTINE MAINTENANCE



Always check that there is oil in the motor.

Check the motor oil every 100 working hours via the relevant measuring caps positioned on the bottom of the petrol motor.

Top up if necessary.

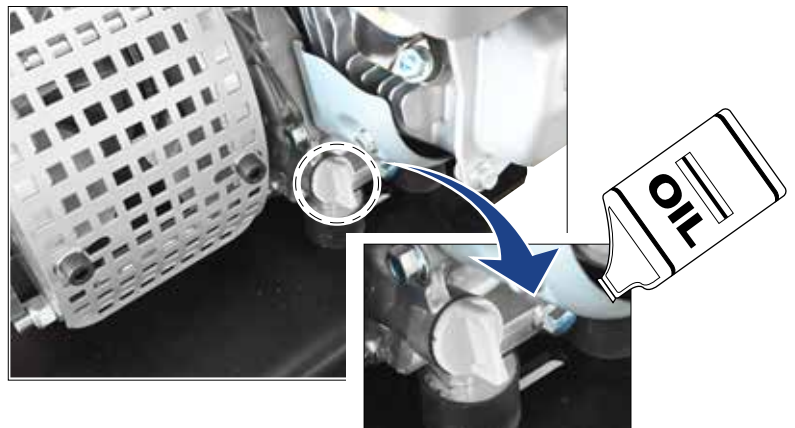

Fig. 1



Fig. 2



CHECK ON THE PACKING NUT

Daily check the packing nut is tight in order to avoid wastes but **not excessively to prevent the piston from seizing and the gaskets from wearing.**

- Use the lubricant (1) supplied (*ref. 16340*) to allow an easy sliding of the piston inside the gasket group.

Daily top up the packing nut.



At the start of each working day check that the ring nut is full of hydraulic oil (Ref. 16340). This oil makes it easier for the piston to slide and prevents any material that escapes via the seal gasket drying when the equipment is stopped.

- For tightening, use the wrench supplied (*ref. 11503*).



Check the packing nut is tight in order to avoid wastes but not excessively to prevent the piston from seizing and the gaskets from wearing.

Ref. 11503
Closing/opening pin

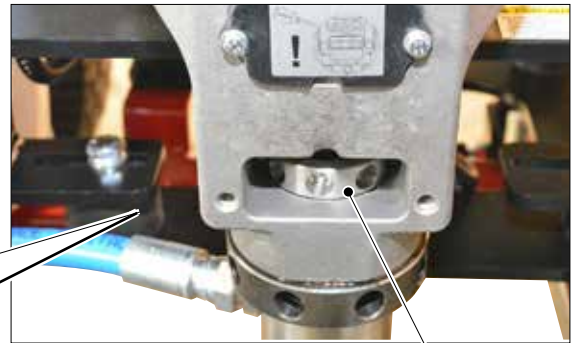
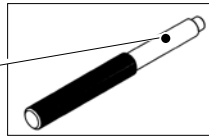

Fig. 3

Oil ring

Q CORRECT PROCEDURE OF DECOMPRESSION

- Move the switch (1) to the **OFF (0)** position to stop the equipment.
- Point the gun (4) at the receptacle (5) used to collect the product and press the trigger to release the pressure. When completed, activate the safety catch again.



Fig. 1

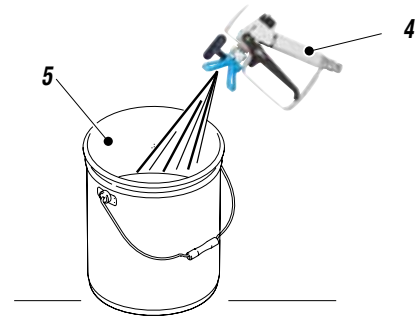

Fig. 4

- Reduce pressure to the minimum (*turn the pressure control knob (2) counterclockwise*).



Fig. 2

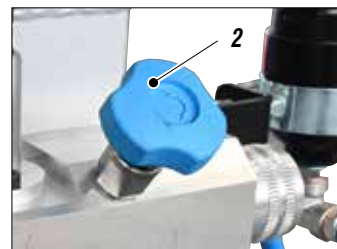
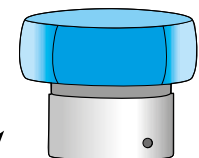

Fig. 5



OPEN
Never spray but
recirculate into the tank

- Unlock the safety clamp (3).

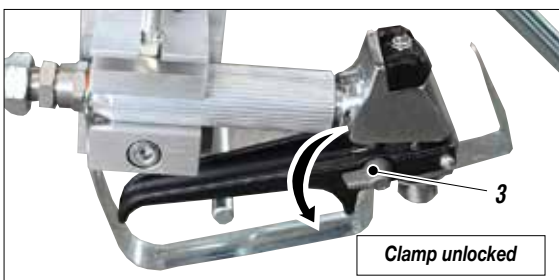

Fig. 3

Clamp unlocked



WARNING:

If the equipment is still under pressure after performing the operations above described because of the nozzle or the flexible hose clogged, proceed as follows:

- Loosen very slowly the gun nozzle.
- Release the clamp.
- Point the gun at the container of the product and press the trigger to release pressure.
- Loosen very slowly the fitting of connection from the flexible hose to the gun.
- Clean or replace the flexible hose and the nozzle.

R REPLACEMENT OF THE PUMPING GROUP'S GASKETS

Each time you use the machine, check for material leaking from the top of the ring nut.

If any material leaks out when the pump is working at the set pressure, proceed as follows:

- Carry out this operation after cleaning the tooling.



Always disconnect the power supply and release pressure before going on with the operations (follow the "correct procedure of decompression").



The gaskets are self-adjusting. If a leak occurs they must be replaced.

- Disconnect the product feed hose (1) from the pump unit by unscrewing the nut (2).
- Unscrew the fixing ring nut (3) using the relevant closing pin (Ref. 20144).

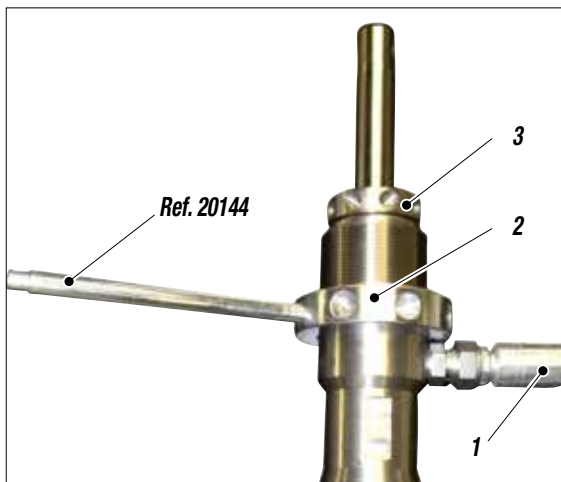

Fig. 1

- Release the plastic cover (4).

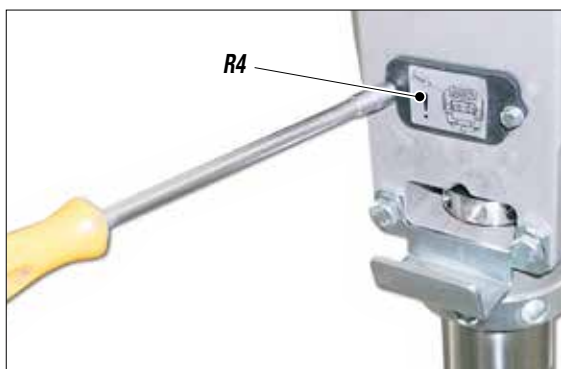

Fig. 2

- Screw the appropriate supplied tool (5) (rif. 20213) into the threaded hole on the holding pin (6).



Fig. 3

- Remove the pin (6) from its seating.

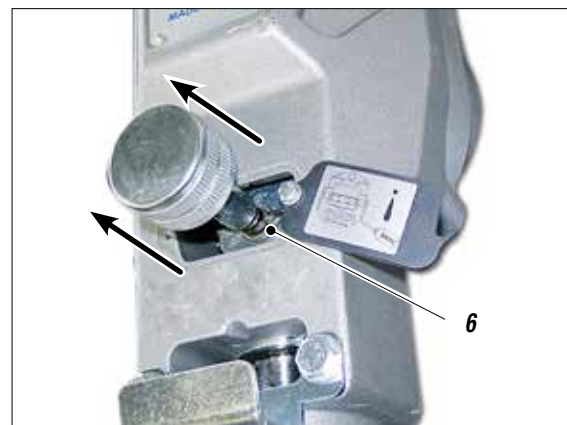

Fig. 4

- Unscrew the pump unit (7) from the frontal flange (8).



Fig. 5

PIT STOP MAINTENANCE

Replacement of upper and lower gaskets 20 minutes.

- Lock the pump unit into a vice and unscrew it with a 50mm wrench;
- Release the pump unit from the body of the suction valve;

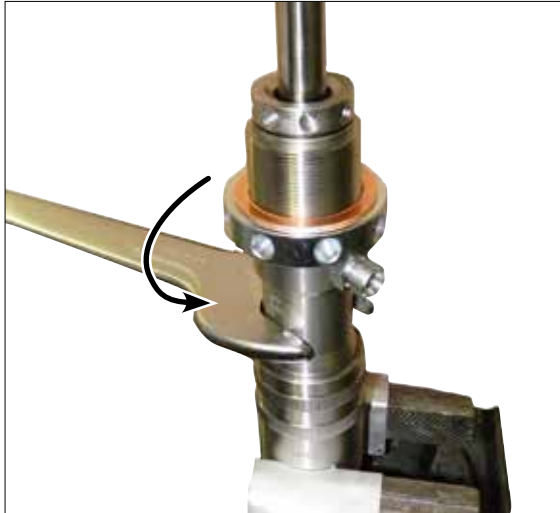

Fig. 6

Lower seal

- Remove the piston stem (9) and remove the pump unit sleeve (10);



Fig. 7

- Grip the stem valve (11) in a vice;



Fig. 8

- Use a size 22 spanner to unscrew the lower stem (12);

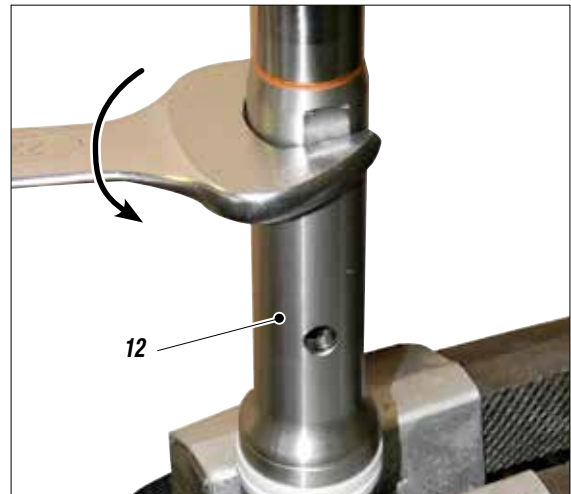

Fig. 9

- Use a screwdriver to remove the two open-ring guide bands (13) and replace them;

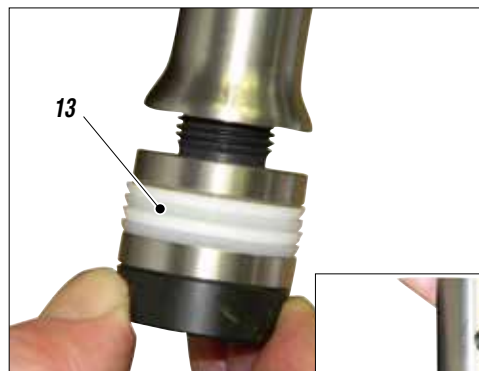

Fig. 10



- Unscrew the stem valve (14) altogether, check the surface of the ball seating (15) that comes into contact with the ball (16). If worn, replace them;



Fig. 11

- Use a screwdriver to remove the O-Ring (17) and replace it making sure it is aligned correctly (as illustrated);

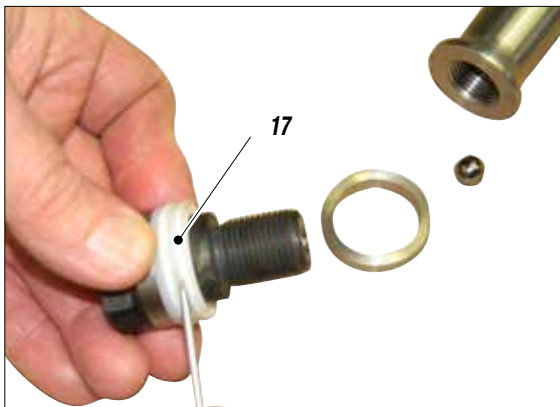

Fig. 12

- Screw the valve stem (14) on again and tighten fully, gripping the valve in a vice. To tighten, use a 22 mm spanner; the use of a thread paste is recommended;

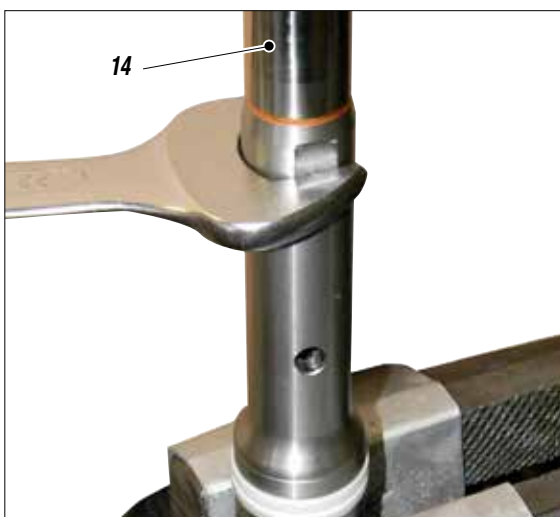

Fig. 13

Upper seal

- Remove the ring nut (18);

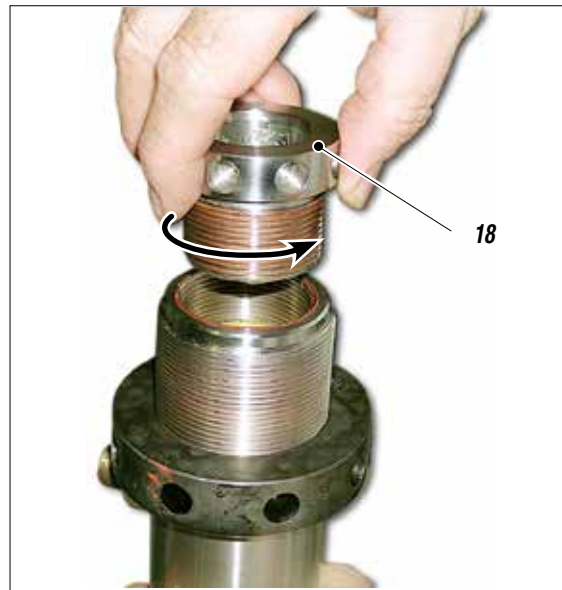

Fig. 14

- Remove the ring (19);

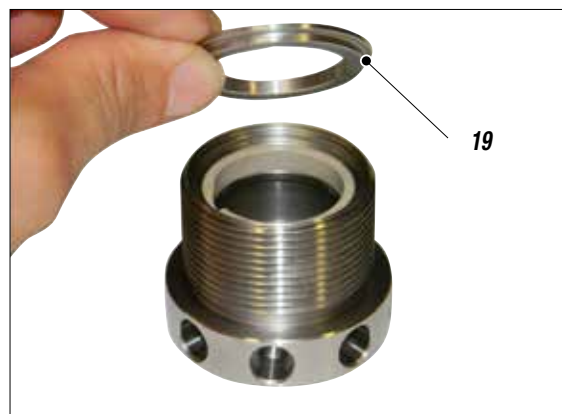

Fig. 15

- Remove the guide band () with a screwdriver and replace it with a new one;

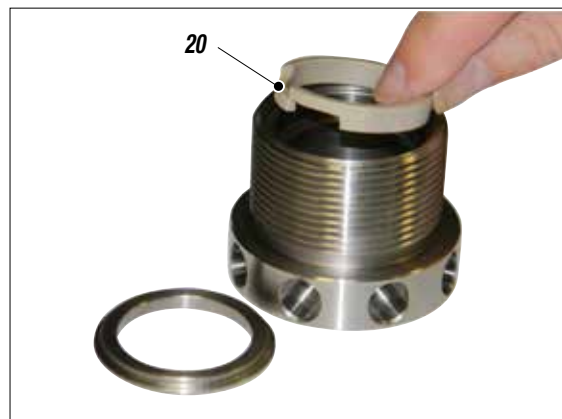

Fig. 16

- Remove the seal (21) with a screwdriver;



Fig. 17

- Using a screwdriver, extract the second band (22) located below the seal (21) and insert a new band in the same position;

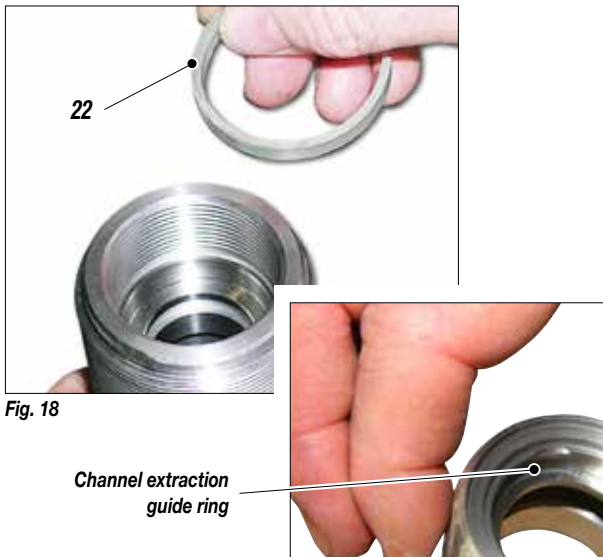

Fig. 18



The positioning of the seal (21) requires special care during assembly.

- Assist insertion by applying leverage to the outside of the ring (21), pushing from the outside inwards and helping the ring to lodge in the seating, while being careful not to damage the ring's contact surfaces.



Lubricate with grease before fitting.

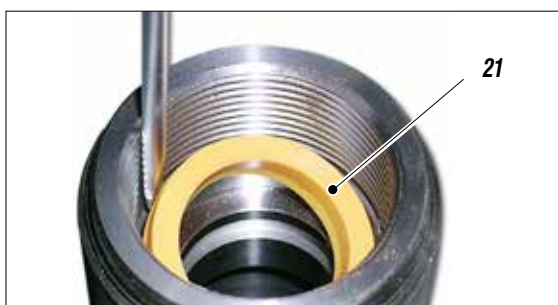

Fig. 19



Only if damaged



- Remove the OR (23-24) from the body of the foot valve (26) and from the ball seat holder (25) and, if necessary, replace them. Reassemble the components in their proper order (as indicated in the diagram);

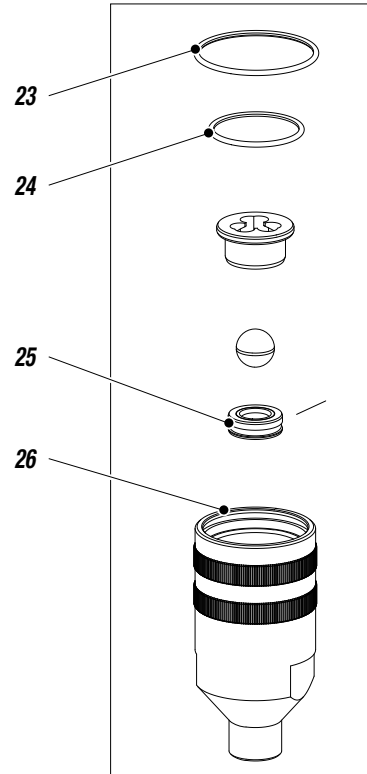

Fig. 20



To facilitate fitting the O-ring (25) it is advisable to warm it slightly with a blast of hot air.

- Check the integrity of the surface area of the sphere in contact with the ball (15). If worn replace the complete detail.

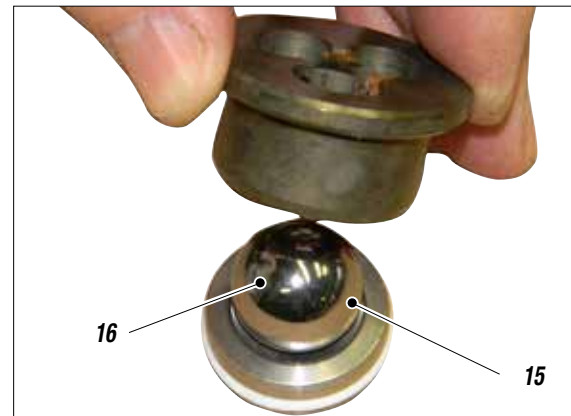

Fig. 21



The ball seating (17) is countersunk on one side, where the ball (18) must sit.

- Screw the locking ring nut (18) back onto the body of the pump unit until it makes contact, then loosen it by one turn;

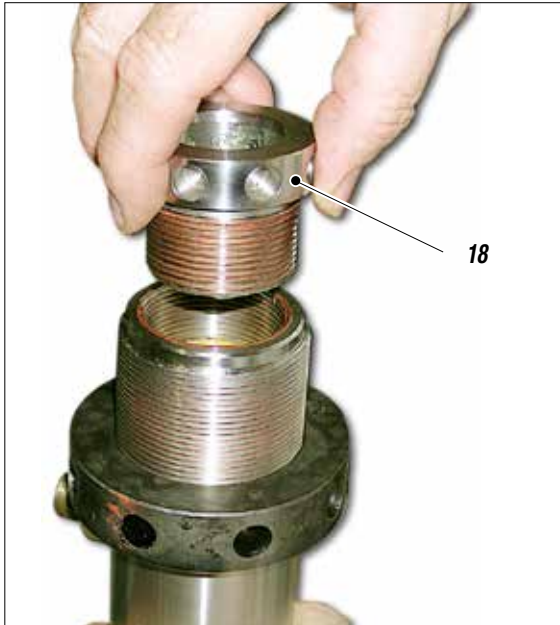
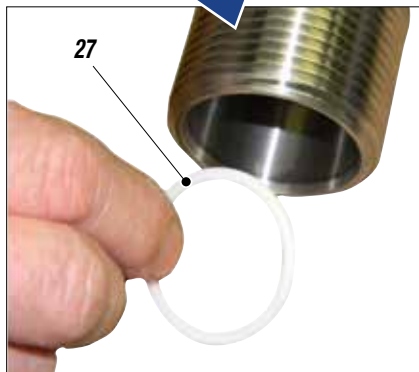

Fig. 22

- Remove the sleeve/cylinder seal (27) and replace it with a new one;



Fig. 23



- Check the wear status of the surfaces inside the jacket. Replace it if necessary;
- Grease the sleeve (28) using a paintbrush;



Fig. 24

- Insert the sleeve (28) into the lower pump unit (29);

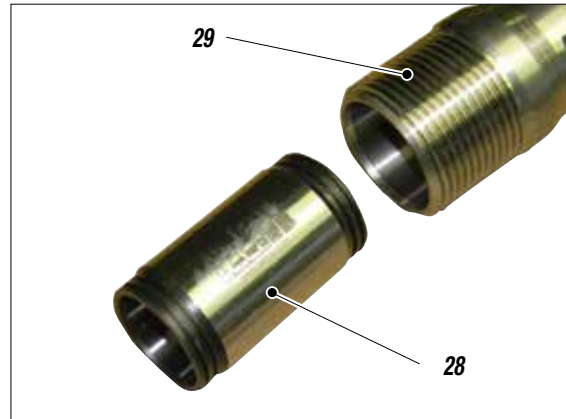

Fig. 25



Insert the complete piston stem (30) after greasing the gaskets (31);



Fig. 26

- Screw on the complete foot valve (26) with the sleeve assembly (27);



In order to guarantee a proper seal, tighten the foot valve (26) fully, using a 50 mm spanner.

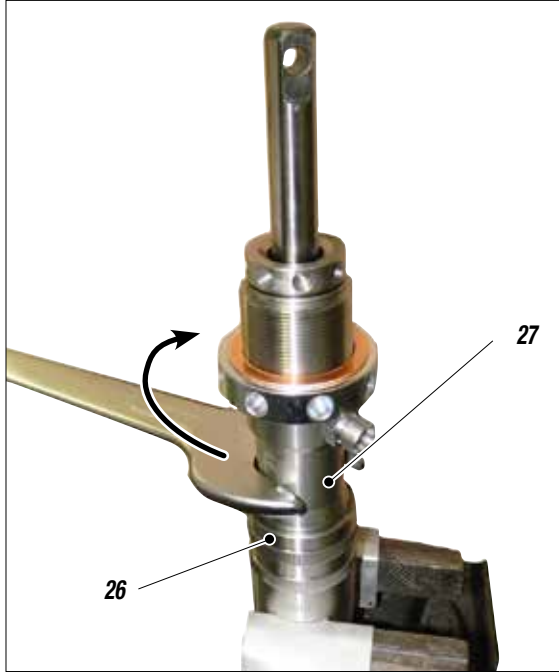

Fig. 27

- When refitting the pump unit on the machine, the stem must be at its highest point possible.
- Insert the stem into the connecting rod and insert the fixing pin (6).



Fig. 28

- Tighten the pump casing all the way and, if the delivery pipe is not correctly aligned, unscrew the pump casing until the connection is in the correct position before tightening by using the ring nut (32) and the pin (33) supplied (Ref. 20144).

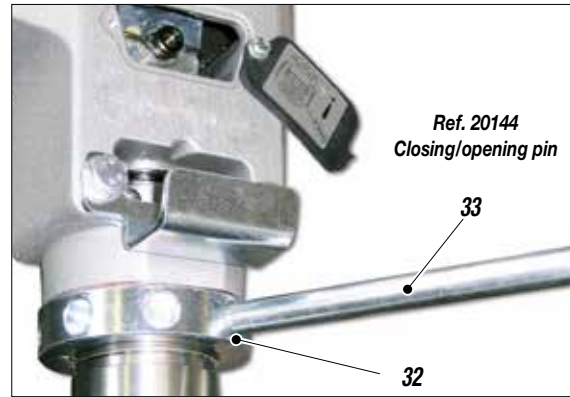

Fig. 29

- Close the seal ring nut (35) all the way.



Fig. 30

- Lubricate the upper crown (36) using oil (37) (Ref. 16325);

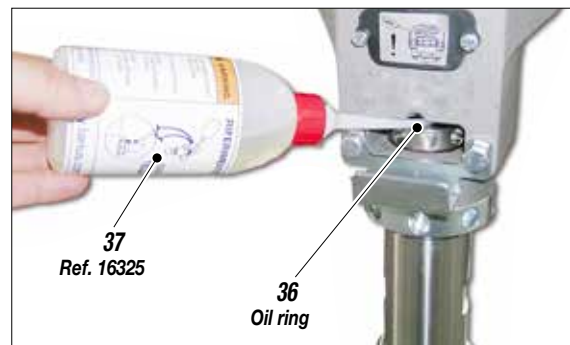

Fig. 31

- Refit the inspection barrier (38);

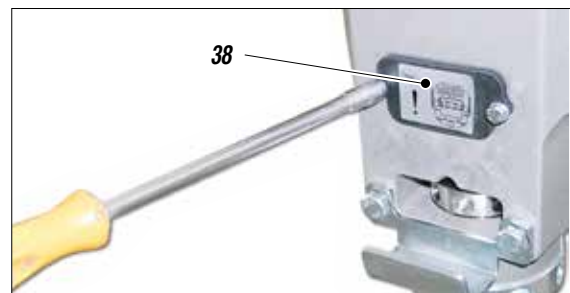

Fig. 32



To assemble all the parts in the correct sequence, see the exploded diagram on page 44.

S PROBLEMS AND SOLUTIONS

Problem	Cause	Solution
The equipment does not start	On/Off switch disconnected;	Ensure the On/Off switch is on the "on" position and turn clockwise the pressure control knob;
	Lack of gasoline;	Add gasoline;
	Breakdown of motor electric control box;	Verify and replace it, if necessary;
	The line of material coming out of the pump is already under pressure;	Open the drain valve to release pressure in the circuit;
	The product is solidified inside the pump;	Open the drain valve to release pressure in the circuit and stop the machine. Disassemble the pumping group and the pressure transmitter and clean;
The equipment does not suck the product	Suction filter clogged;	Clean or replace it;
	Suction filter too fine;	Replace it with a larger-mesh filter (with very dense products, remove the filter);
	Product output valve closed;	Open the product output valve;
	The equipment sucks air;	Check the suction pipe;
The equipment sucks but does not reach the pressure desired	Lack of product;	Add the product;
	The equipment sucks air;	Check the suction pipe;
	The recirculating-safety valve is open;	Close the recirculating-safety valve;
	The gaskets of the pumping group are worn;	Replace the gaskets;
	Suction or delivery valve dirty;	Disassemble the pumping group;
When pressing the trigger, the pressure lowers considerably	Nozzle too big or worn;	Replace it with a smaller one;
	The product is too dense;	Dilute the product, if possible;
	The filter of the gun-butt is too fine;	Replace it with a larger-mesh filter;
The pressure is normal but the product is not atomized Leakage from the seal-tightening screw	The nozzle is partially clogged;	Clean or replace it;
	The product is too dense;	Dilute the product, if possible;
	The filter of the gun-butt is too fine;	Replace it with a larger-mesh filter;
The atomization is imperfect	The nozzle is worn;	Replace it;
When releasing the trigger of the gun, the equipment does not stop (the motor runs slowly and the piston rod keeps on going up and down)	The gaskets of the pumping group are worn;	Replace the gaskets;
	Suction or delivery valve dirty;	Disassemble the pumping group and clean;
	Recirculating-safety valve defective.	Verify and replace it, if necessary.



Always close the air compressed supply and unload the plant pressure before performing any check or replacement of pump parts (see "*correct procedure of decompression*").

SPARE PARTS

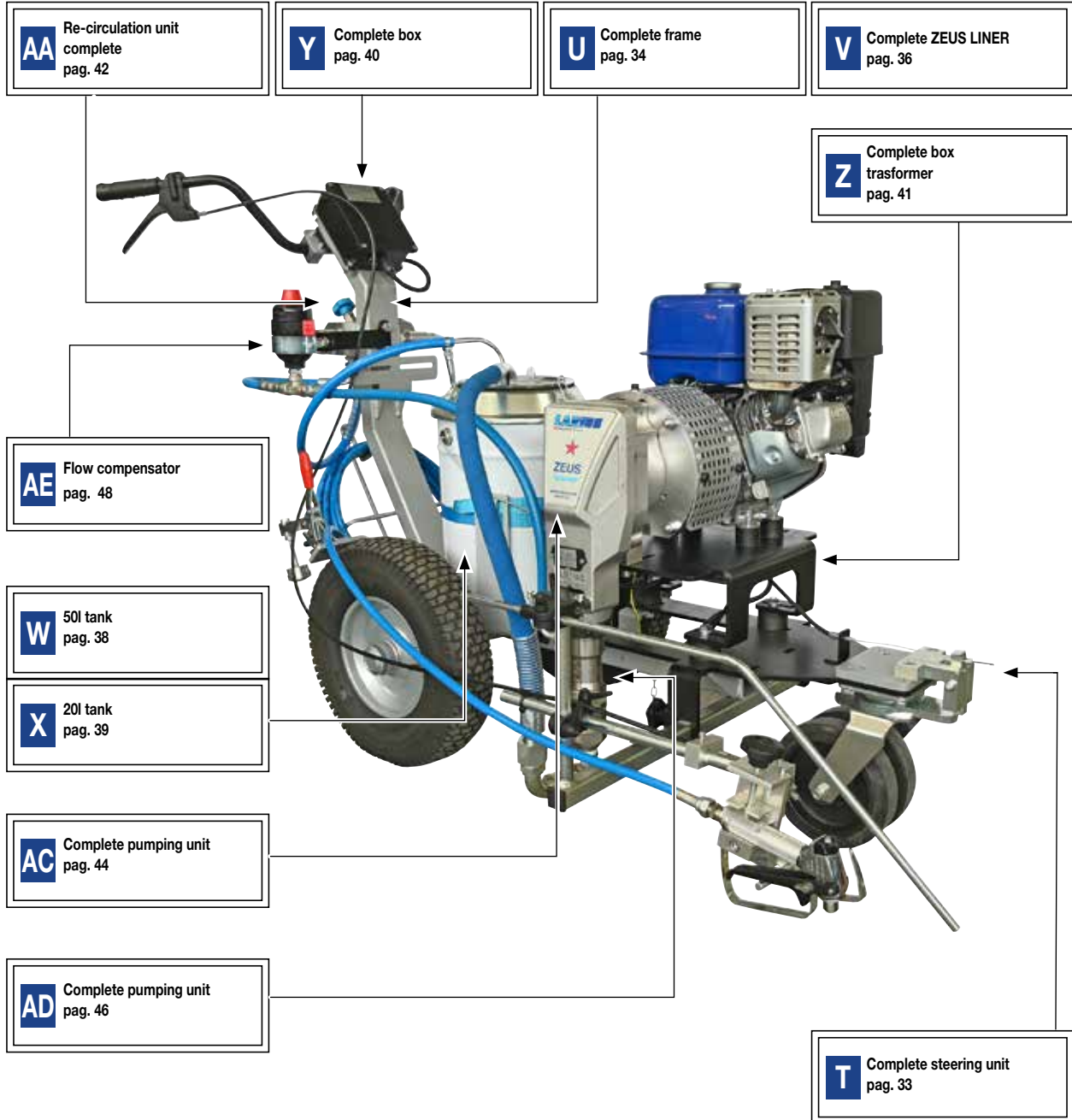

Intentionally blank page

T COMPLETE STEERING UNIT REF. 4555

WARNING: Always indicate code and quantity for each part required.

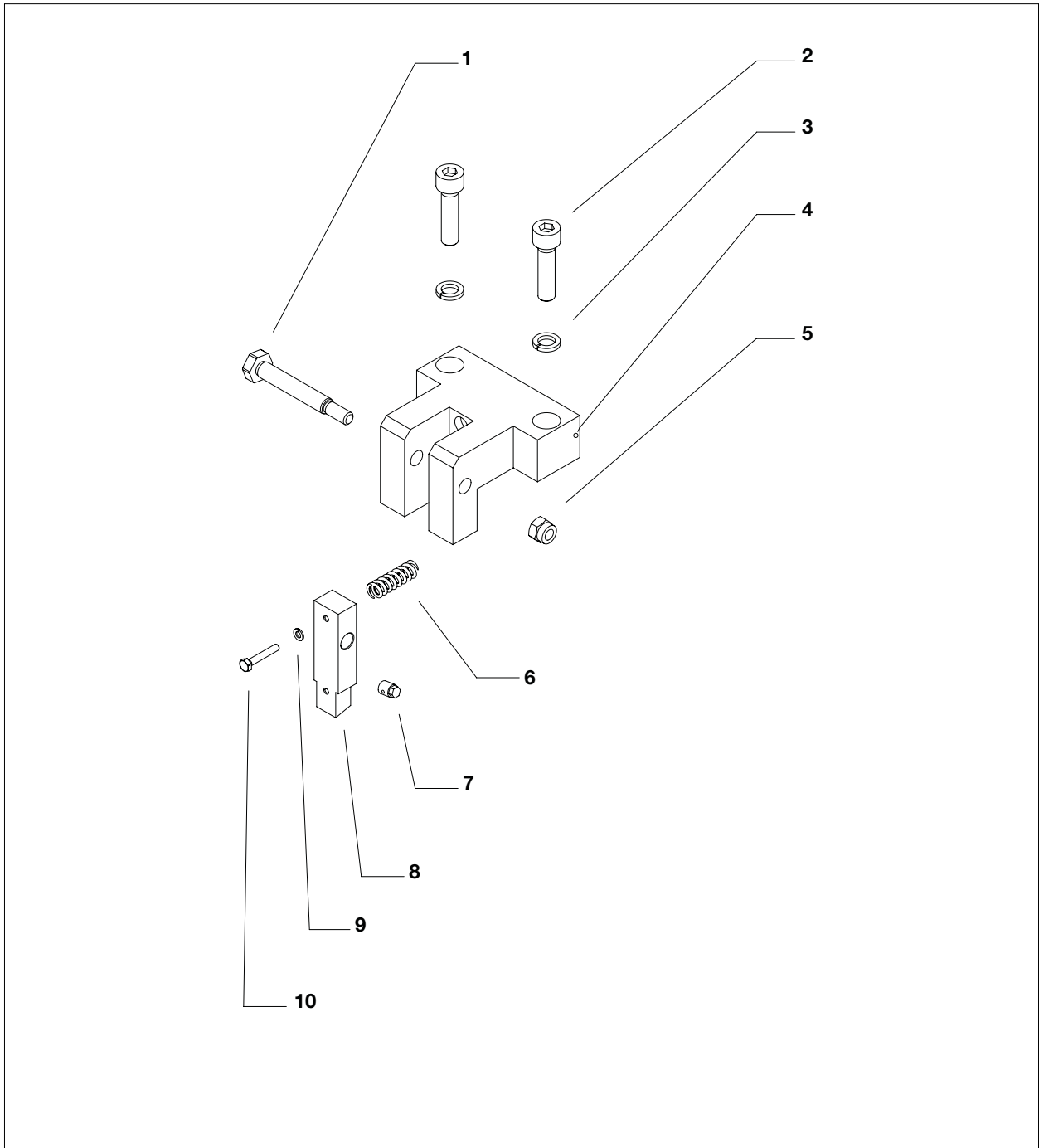

Pos.	Code	Description
-	4555	Complete steering unit
1	4735	Screw
2	4841	Screw
3	330058	Washer
4	4737	Base
5	3637	Nut

Pos.	Code	Description
6	92038	Spring
7	4253	Wire stopper
8	4736	Pin
9	5339	Washer
10	4739	Screw

U COMPLETE FRAME UNIT REF. 4565 (REF. 4555 INCLUDED)

WARNING: Always indicate code and quantity for each part required.

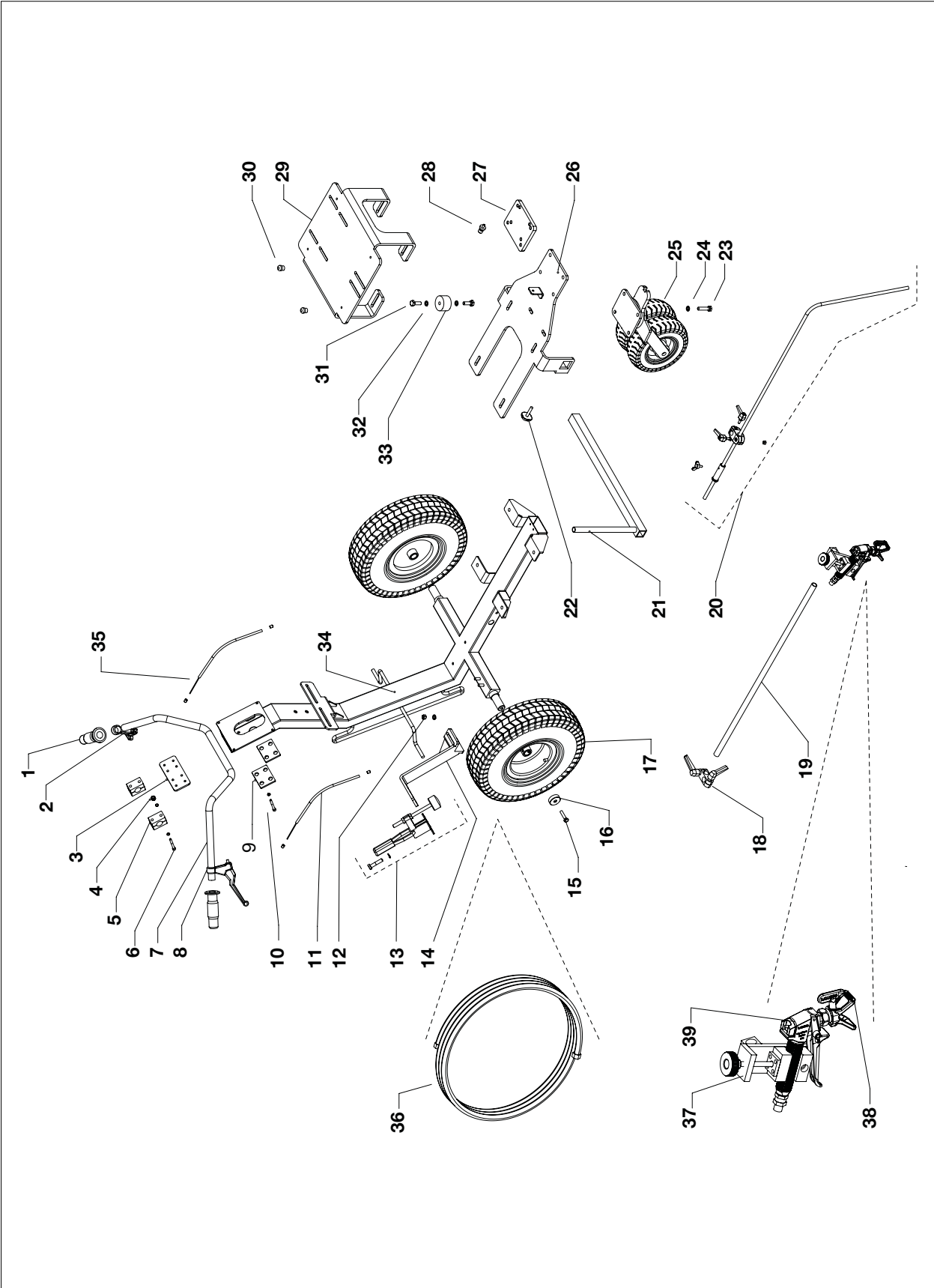

Pos.	Code	Description
-	4565	Full frame group
1	4256	Handle
2	4463	Left lever
3	4562	Plate
4	8042	Self-locking nut
5	4866	Block
6	7043	Screw
	32005	Washer
7	4865	Handlebar
8	4464	Right Lever
9	4824	Plate
10	7043	Screw
	32005	Washer
11	4873	Complete cable
12	3637	Nut
	34009	Washer
13	4868	Complete brake
14	4867	Brake support
15	8371	Screw
16	4492	Washers
	96030	
17	4461	Wheel
18	4869	Block

Pos.	Code	Description
19	4450	Rod
20	26020	Pointer unit
21	4429	Gun support
22	4490	Block
23	95156	Screw
24	95096	Washer
25	4732	Pivoting wheel
26	4566	Primary plate
27	4872	Plate
28	4265	Wire lock
29	4559	Motor plate
30	20450	Cable fastener Gj1/4
31	95156	Screw TE M10x30
32	81033	Washers
	95096	
33	20537	Anti-vibration 50x30 m10
34	4864	Frame
35	4873	Cable complete with control
36	18026	Compensation tube 1/4" 15m rac.M16x1.5
37	4448	Complete spray gun support unit
38	4833	Fast Clean small Liner accessory
39	11210	Complete spray gun AT 250
-	8079	Technical data plate

V COMPLETE ZEUS LINER REF. 4554

WARNING: Always indicate code and quantity for each part required.

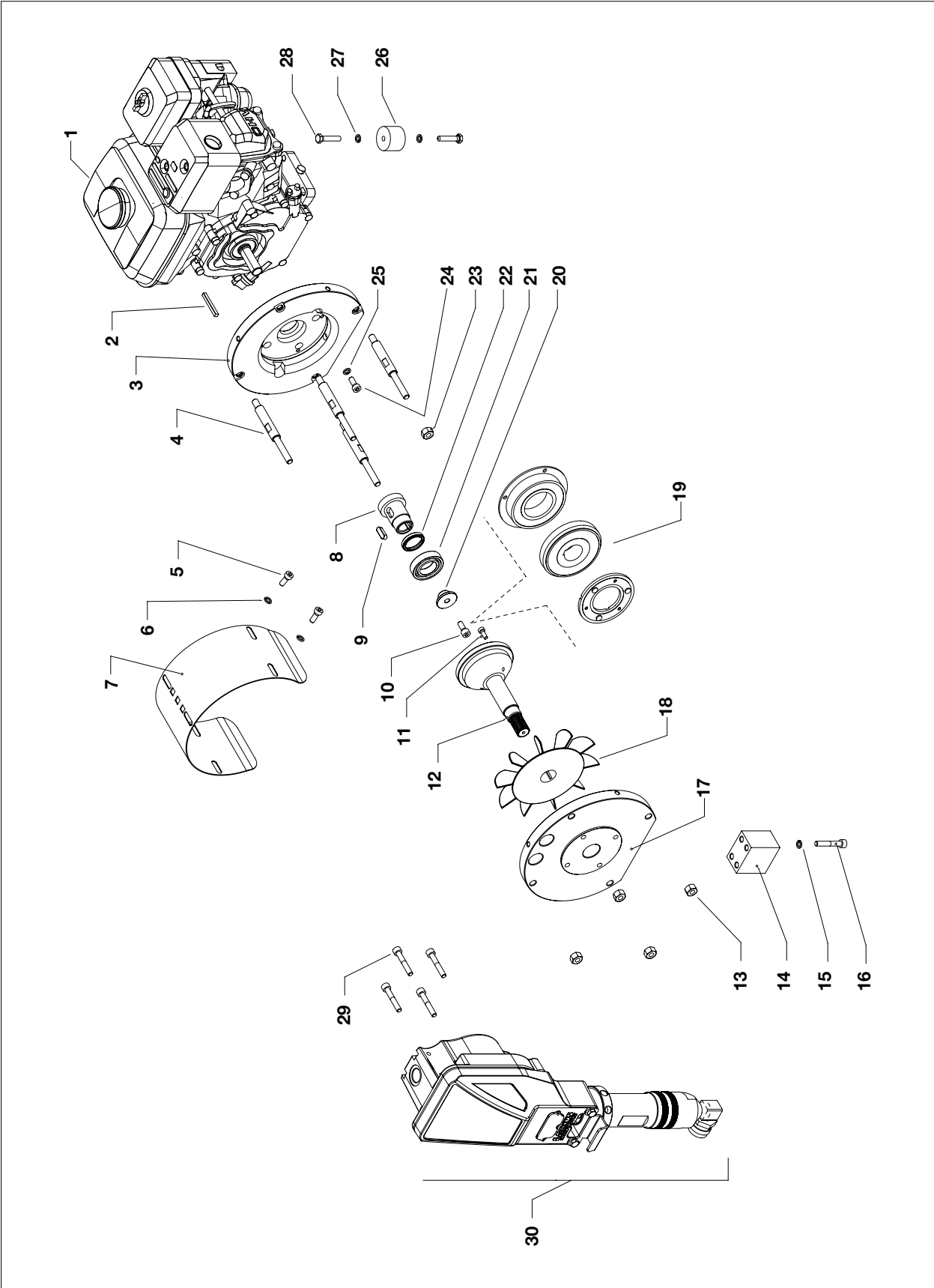

Pos.	Code	Description
-	4554	Complete ZEUS LINER unit
1	4889	Motor
-	18392	Yamaha MZ 175 motor exhaust kit
2	4244	Tab
3	4887/1	Flange
4	4886	Tightening rod
5	96031	Screw
6	34009	Washer
7	4888/1	Cover
8	4885/1	Bush
9	4435	Tab
10	96031	Screw
11	32032	Screw
12	4558	Pinion
13	96080	Nut
14	4556	Spacer
15	34009	Washer

Pos.	Code	Description
16	5783	Screw M8x80
17	4557	Reduction flange
18	20531	Fan
19	4416	Complete clutch MK3
20	4882/1	Washer
21	4883	Bearing
22	4884	Spacer
23	95158	Nut
24	54004	Screw
25	32005	Washer
26	81107	Vibration-damping pad 40x30 M8
27	34009	Washer
28	69016	Screw
29	96031	Screw
30	4553	Zeus Liner reduction unit
-	16656	Warning tags
-	16325/1	

W COMPLETE 50L TANK REF. 4895

WARNING: Always indicate code and quantity for each part required.

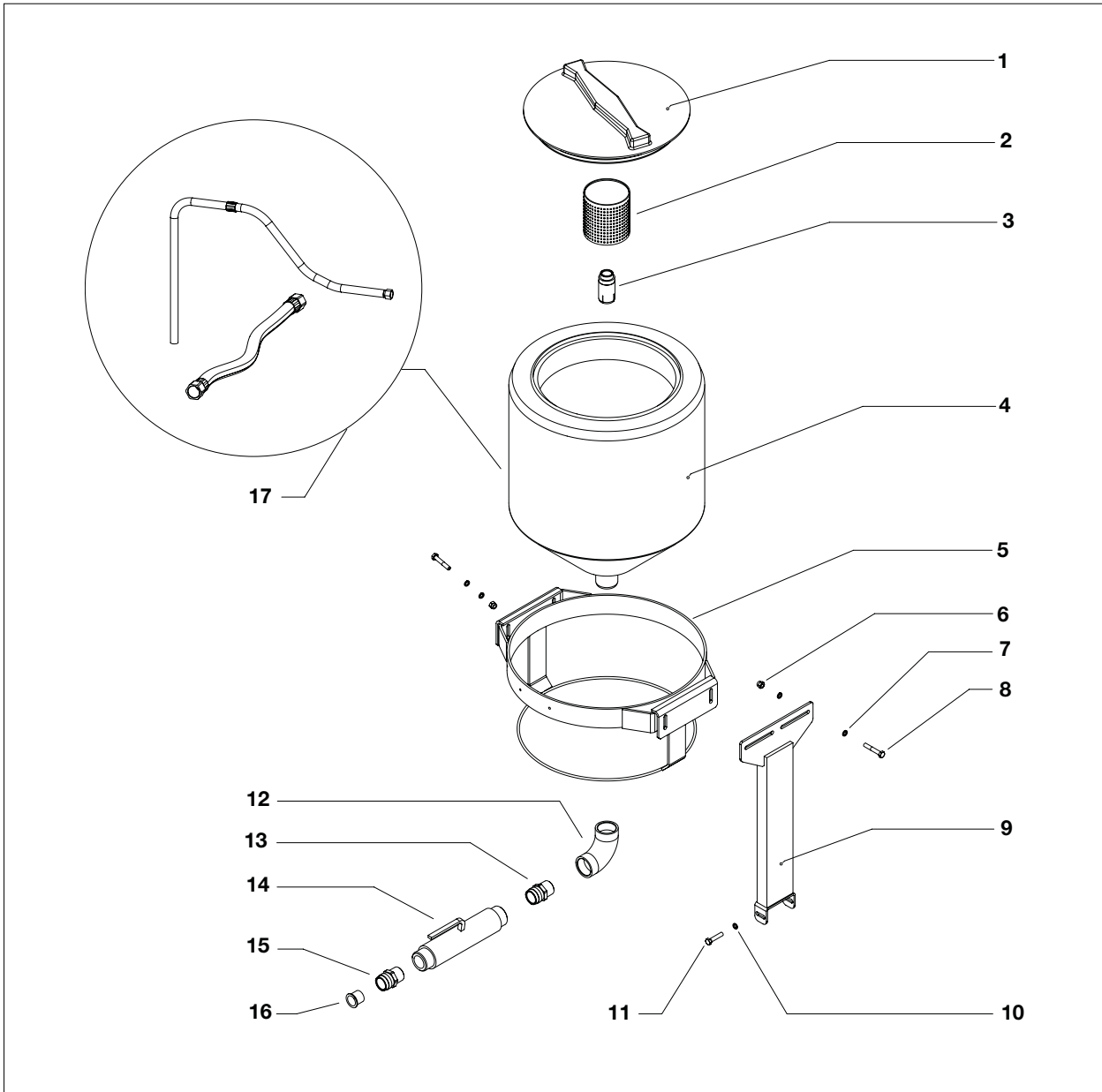

Pos.	Code	Description
-	4895	Complete 50L Tank
1	18249/1	Cover
2	85014	Filter
3	18231	Support
4	18249	50L Tank
5	18246	Support
6	3637	Nut
7	96030	Washer
8	901568	Screw
9	4894	Support

Pos.	Code	Description
10	96030+ 32024/1	Washers
11	901568	Screw
12	20833	Elbow
13	8375	Union
14	30532	Valve
15	95032	Union
16	96099	Seal
17	4834	Complete suction+output system

X COMPLETE 220L TANK REF. 4890

WARNING: Always indicate code and quantity for each part required.

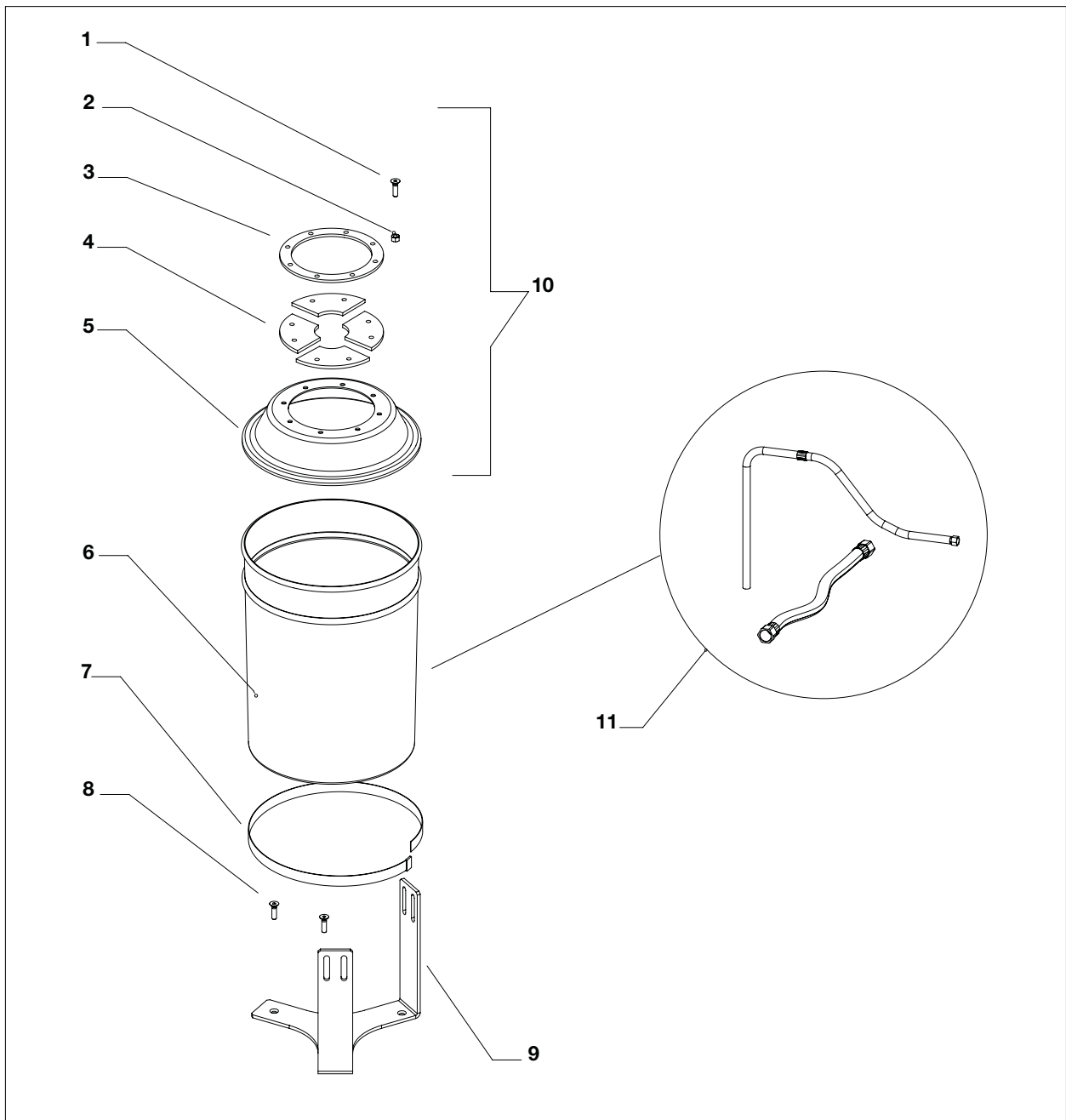

Pos.	Code	Description
-	4890	Complete 20L Tank
1	4314	Screw
2	52017	Nut
3	4308	Ring
4	4309	Rubber
5	4109	Cover

Pos.	Code	Description
6	4064	20l Tank
7	4274	Belt
8	69014	Screw
9	4250	Base
10	4111	Cover complet
11	16676	Complete suction+output system

Y COMPLETE BOX REF. 4896

WARNING: Always indicate code and quantity for each part required.

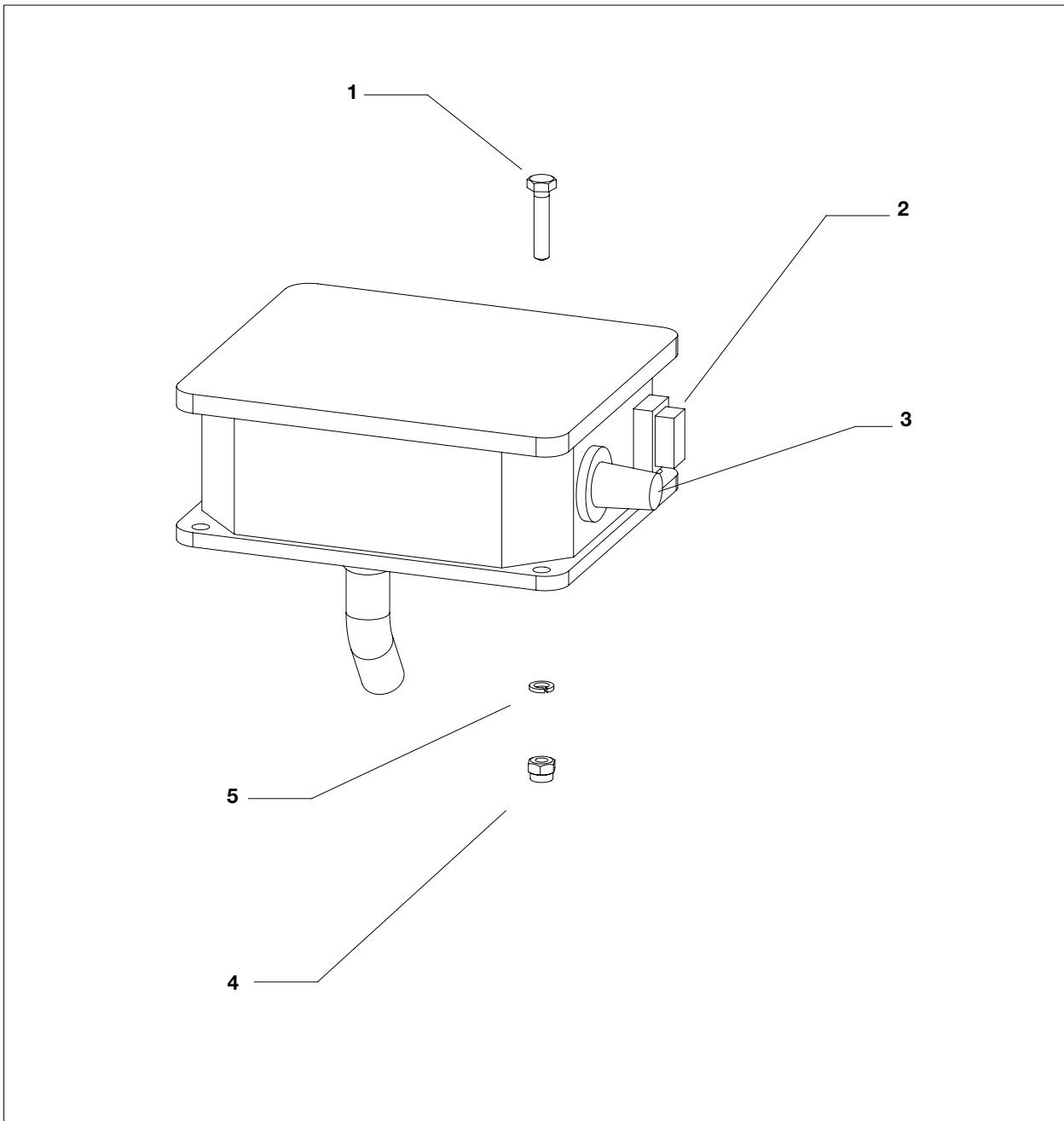

Pos.	Code	Description
-	4896	Complete box
1	91062	Screw
2	5933	Switch ON/OFF
3	30549	Potentiometer

Pos.	Code	Description
4	8042	Nut
5	32005	Washer
6	16850	Warning stickers

Z COMPLETE BOX TRASFORMER REF. 4845

WARNING: Always indicate code and quantity for each part required.

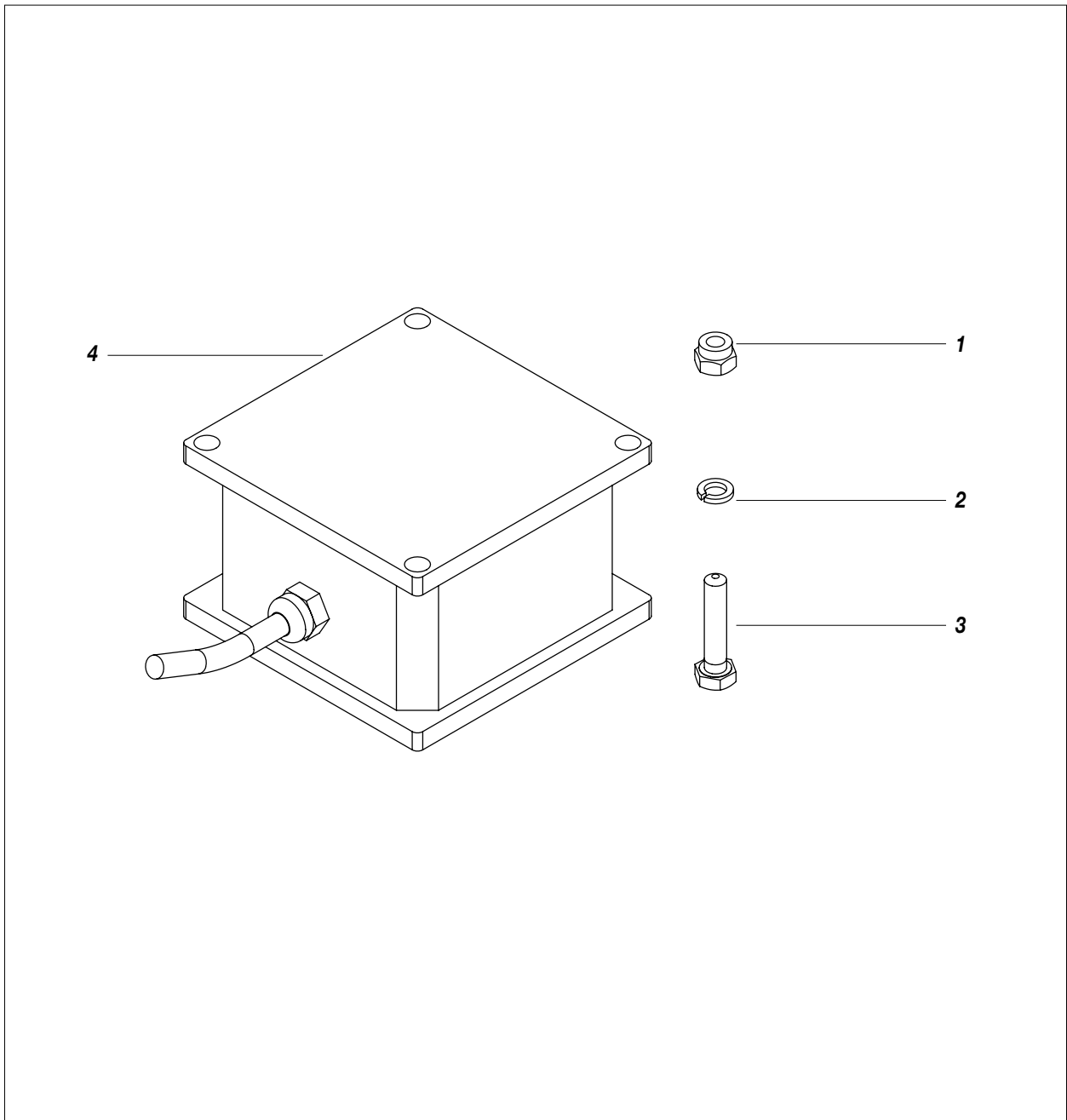

Pos.	Code	Description
-	4845	Complete box transformer
1	8042	Nut
2	32005	Washer

Pos.	Code	Description
3	91062	Screw
4	4846	Transformer box

AA COMPLETE MECHANICAL UNIT

WARNING: Always indicate code and quantity for each part required.

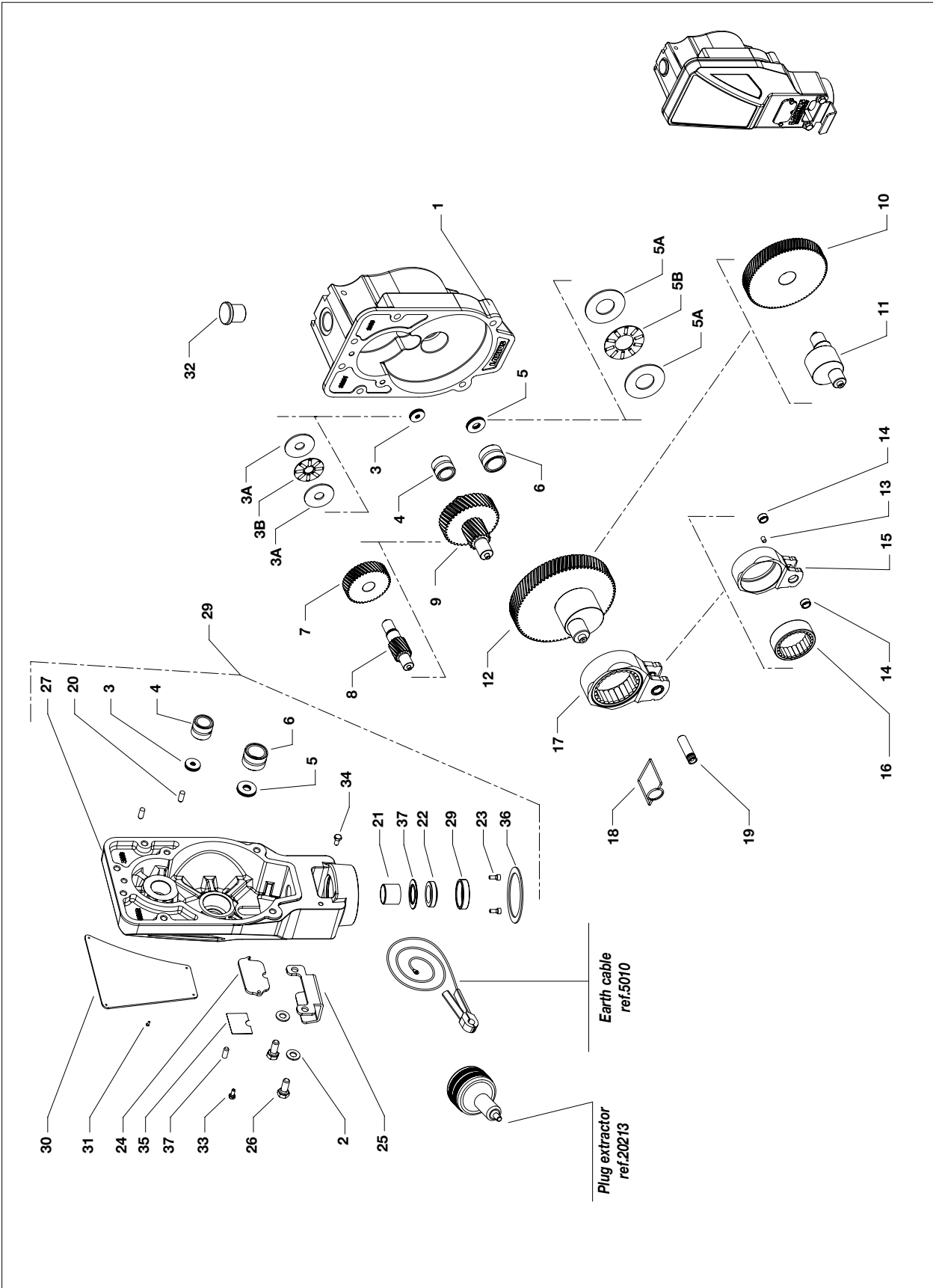

Pos.	Code	Description	Q.ty
-	35144	Complete mechanical unit	1
1	30201	Flange motor	1
2	34009	Washer Ø 8	6
3	20250	INA Thrust bearing complete	2
3A	20251	Fifth wheel	4
3B	20252	Cage	2
4	20253	INA Roller bearing	2
5	30254	Thrust	2
5A	30255	Fifth wheel	4
5B	30256	Cage	2
6	30257	INA Roller bearing	2
7	20205	Toothed wheel court	1
8	20204	Court toothed	1
9	20258	Toothed driving assembly	1
10	20207	Eccentric sprocket	1
11	30206	Eccentric cam	1
12	30259	Cam assembly	1
13	30272	Spacer pin Ø 6X10	1
14	30208	Guide bushing	2
15	30209	Connecting rod	1
16	30261	INA Roller bearing	1

Pos.	Code	Description	Q.ty
17	30262	Complete connecting rod	1
18	30263	Positioning spring	1
19	30210	Pump unit pivot	1
20	20264	Centring pin Ø 6X20	2
21	30665	Guide bushing	1
22	30266	Scraper	1
23	5378	Screw M4X10	2
24	30211	Inspection hatch	1
25	30212	Tin plate door	1
26	69011	Screw M8X20	2
27	30202	Reduction unit cover	1
28	35141	Cover assembly	1
29	30214	Fixing ring	1
30	35143	Front sticker	1
31	34020	Rivet Ø 2 mm	6
32	21688	Plug	1
33	20245	Screw M4X10	1
34	96211	Screw M6X10	1
35	30274	Warning stickers	1
36	30666	Tightening ring	1
37	30225	Fixing ring	1
38	20278	Cylindrical pin	1

AB COMPLETE PUMPING UNIT

WARNING: Always indicate code and quantity for each part required.

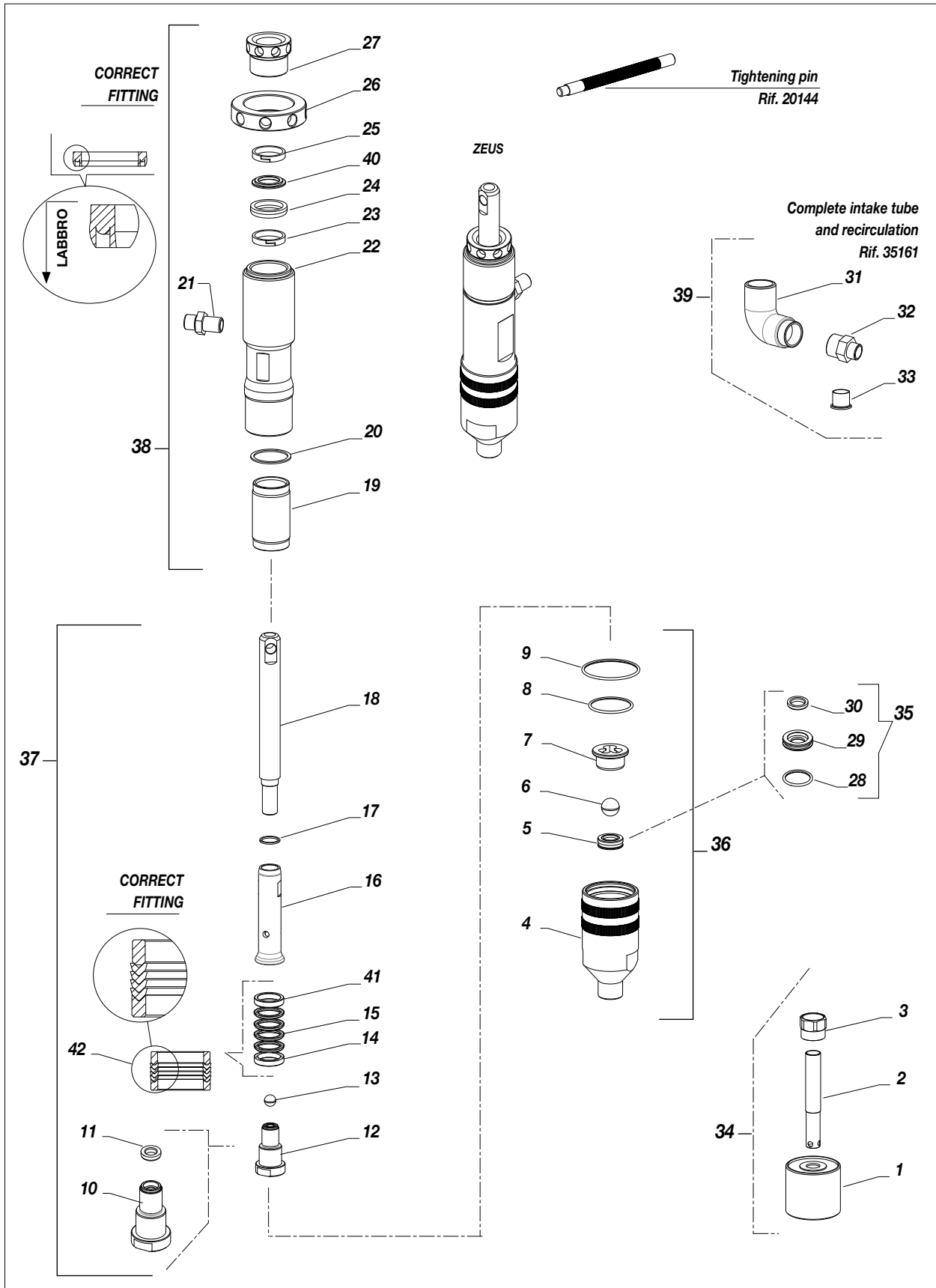

Pos.	Code	Description	Q.ty
-	35110	Complete standard pump unit	-
-	35111	Complete pumping with suction hose	-
-	35112	Foot valve seal kit	-
-	35113	Complete seal kit	-
-	35114	Jacket+piston kit	-
-	35161	Suction hose kit + recirculation	-
1	37216	Suction filter	1
2	35118	Hard suction hose	1
3	37229	Connection	1
4	35115	Foot valve	1
5	35116	Assembled at Ball	1
6	35163	Ball Ø 3/4"	1
7	35138	Ball guide	1
8	35121	OR 3156	1
9	35122	OR 3206	1
10	35124	Valve stem	1
11	7062	See ball	1
12	35125	Complete valve stem	1
13	7071	Ball Ø 9	1
14	35151	Ring female lower	1
15	35154	Polyethylene gasket	2
	35157	PTFE gasket	2
16	35129	Lower stem	1
17	37180	O-Ring	1
18	35131	Upper stem	1

Pos.	Code	Description	Q.ty
19	35133	Sleeve	1
20	35134	Seal	1
21	95230/1	Adapter 3/8 AP M-M	1
22	35135	Pump unit casing	1
23	30142	67806-X0220-56Z	1
24	30139	EAR 148856-02	1
25	30138	67806-X0220-A22Z	1
26	30114	Tightening ring nut	1
27	30113	Stuffing nut	1
28	35162	OR 3087	1
29	35119	Accommodation ball seat	1
30	96836/2	See ball	1
31	98374	Elbow joint F-F Gj 3/4	1
32	98376	Suction fitting Jas M-M Gc 3/4 - M36x2	1
33	96099	Seal sleeve	1
34	35139	Assembly float rigid	
35	35117	Assembly the valve seat F	
36	35123	Assembly the group see fund	
37	35132	Assembly the stem	
38	35136	Assembly cylinder	
39	35137	Suction hose Assembly kit	
40	30122	Ring seal top awards	1
41	35142	Ring male lower	1
42	35159	Pack lower packing	1

AC FLOW COMPENSATOR

WARNING: Always indicate code and quantity for each part required.

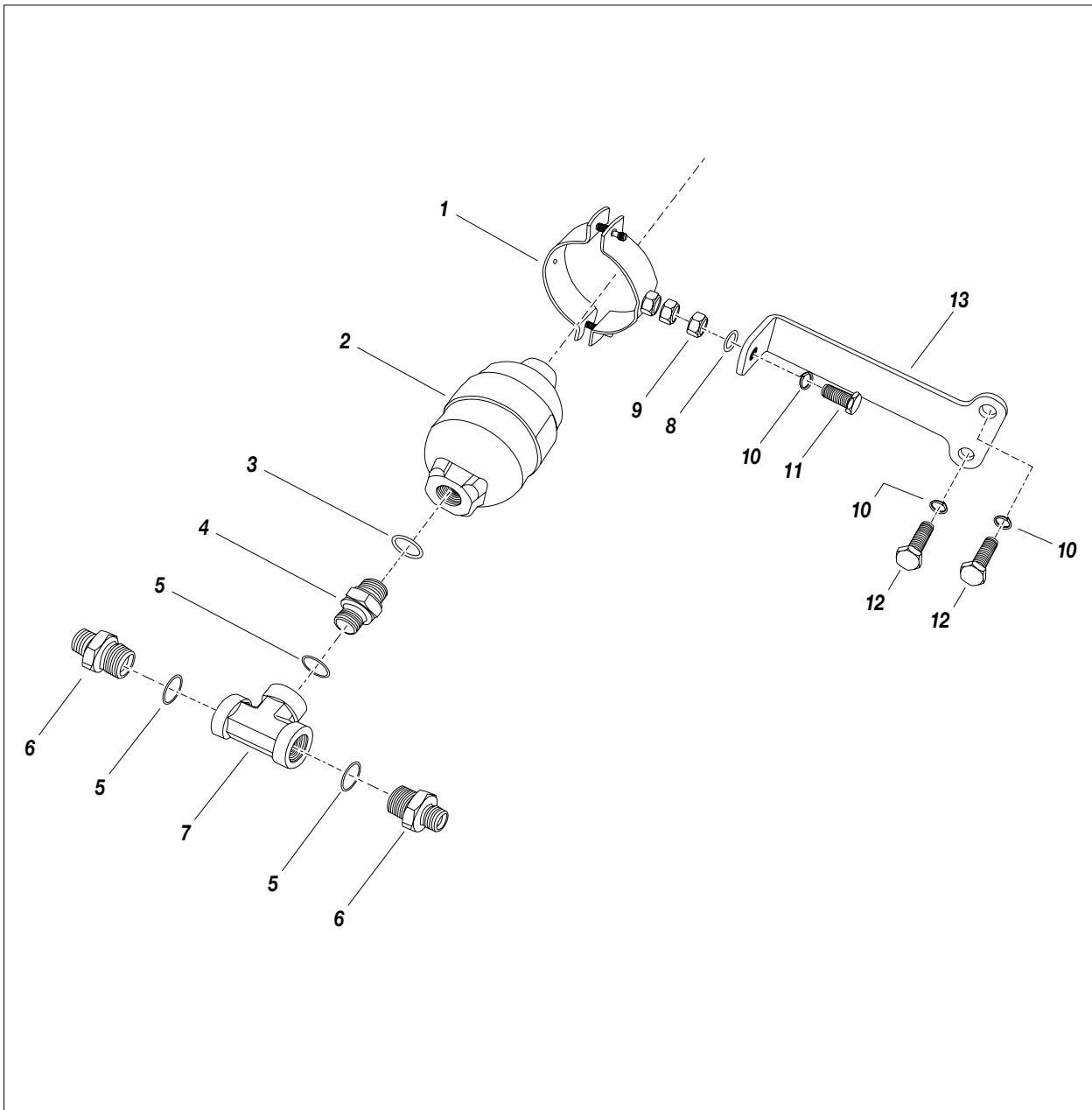

Pos.	Code	Description	Q.ty
1	4522	Collar	1
2	3372	Flow compensator	1
3	37180	Gasket	1
4	3283	Union	1
5	33010	Gasket	3
6	34109	Union	2
7	8078/1	T fitting	1

Pos.	Code	Description	Q.ty
8	81033	Washer	1
9	96080	Nut	1
10	95096	Washer (Typ Grower)	3
11	4407	Screw	1
12	20560	Screw	2
13	4847	Bracket	1

AD RE-CIRCULATION UNIT COMPLETE REF. 4893

WARNING: Always indicate code and quantity for each part required.

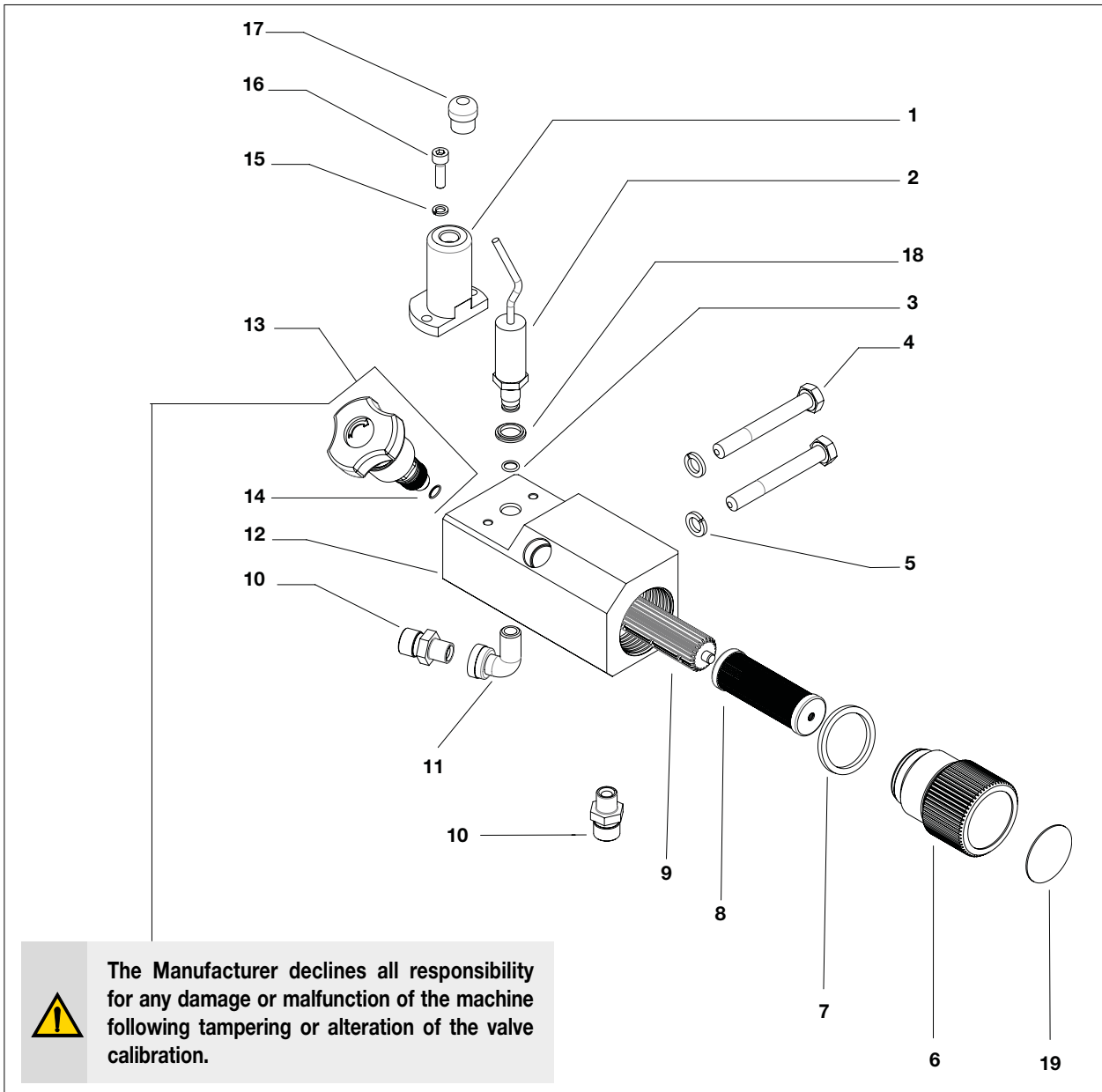

Pos.	Code	Description
-	4893	Re-circulation unit complete
1	4891	Cover
2	18692	Sensor
3	18689	Or Seal
4	33004	Screw
5	33005	Washer
6	56534	Plug
7	56535	Seal
8	16205	Filter
9	18627	Sieve

Pos.	Code	Description
10	96206	Union
11	18614	Union
12	4892	Base
13	16400	Valve
14	4033	O-Ring
15	32005	Washer
16	91062	Screw
17	18871	Cable fastener
18	18684	Copper gasket
19	18657	Pressure label

AE GUNS ARM KIT REF. 26011

WARNING: Always indicate code and quantity for each part required.

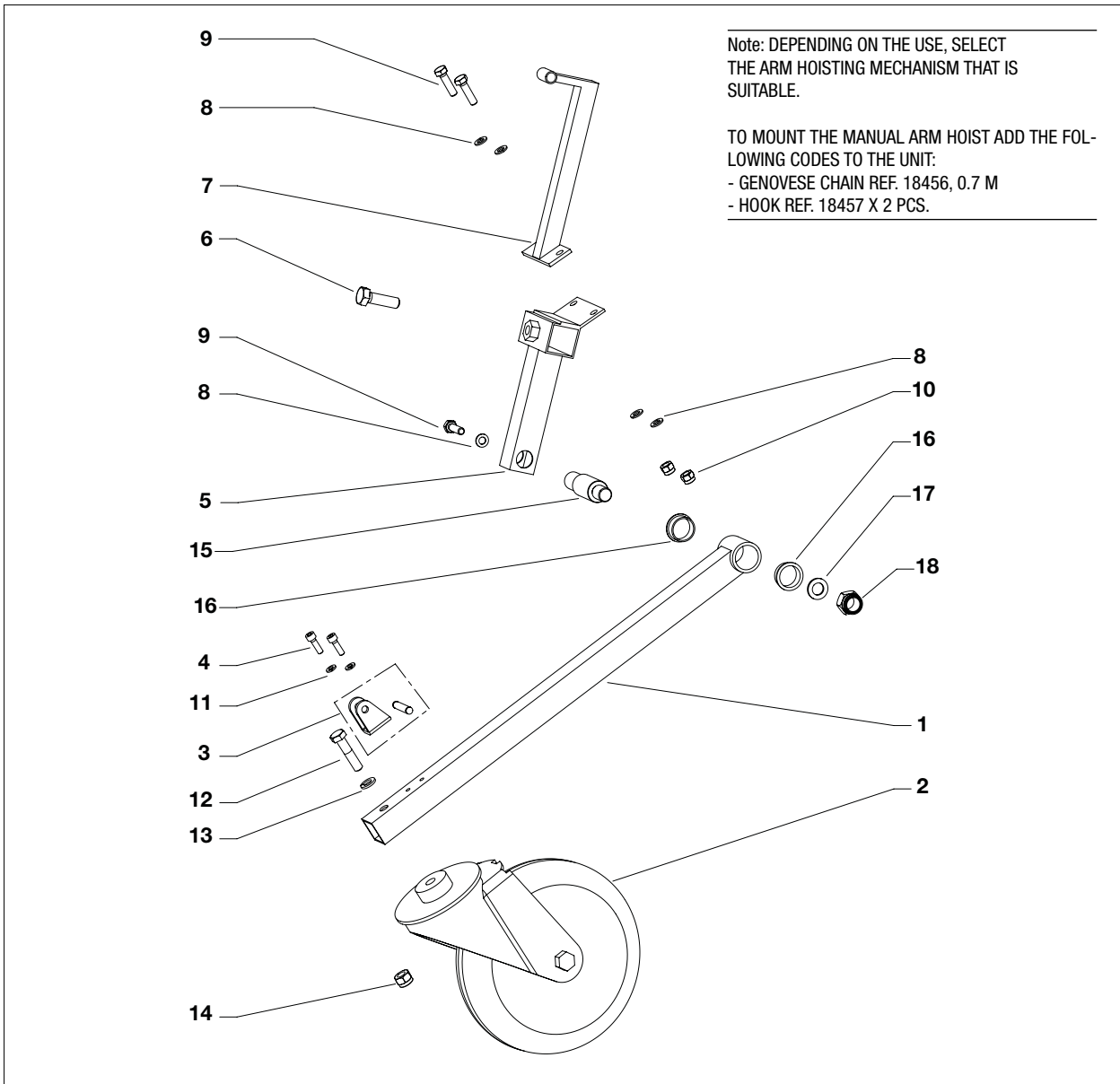

Pos.	Code	Description
-	26011	Guns arm unit
1	26012	Guns arm
2	23444	Pivoting wheel 160/40-80
3	4757	Hinge complete with pin
4	91062	Screw TCE UNI M6x20
5	26013	Joint for gun arm
6	95083	Screw TCE UNI M12x40
7	26015	Joint to connect gun arm
8	510026	Washer ø 8
9	8385	Screw UNI M8x30

Pos.	Code	Description
10	3637	Self-locking nut M8
11	32005	Washer Schnor ø 6
12	20539	Screw TE UNI M10x75
13	95096	Washer Grower ø 10
14	96080	Self-locking nut M10
15	26017	Joint pin
16	26972	Bush
17	95666	Flat washer ø 16
18	95013	Self-locking nut M16



CE DECLARATION OF CONFORMITY



Company



LARIUS srl
Via Antonio Stoppani 21 - 23801 Calolziocorte (LC) ITALY
Tel: +39 0341 621152
Fax: +39 0341 621243
E-mail: larius@larius.com

Declares under his owns responsibility that the product:

ZEUS LINER **Street marking with piston pump**

complies with the directives:

- EC Directive 2006/42 Machinery Directive
- EU Directive 2014/30 Electromagnetic Compatibility (EMC)
- EU Directive 2014/35 Low Voltage (LVD)

furthermore to the
harmonized standards:

- UNI EN ISO 12100-1/-2
Machinery safety, basic concepts, general principles of design. Basic terminology, methodology. Technical principles.

This declaration relates exclusively to the product in the state in which it was placed on the market, and excludes components or modifications which are added or carried out subsequently by end user.

Signature

Pierangelo Castagna
Managing Director

Calolziocorte, 22 December 2023
Location / Date



SAMOA INDUSTRIAL, S.A. - HEADQUARTERS
SPAIN AND EXPORT MARKETS
 POL. IND. PORCEYO, I-14 - CAMINO DEL FONTÁN, 831
 E-33392 GIJÓN (ASTURIAS), SPAIN
 TEL.: +34 985 381 488 - FAX: + 34 985 147 213

SAMOA S.A.R.L.
FRANCE
 P.A.E.I. DU GIESSEN
 3, RUE DE BRISCHBACH
 67750 SCHERWILLER, FRANCE
 TEL.: +33 3 88 82 79 62 - FAX: +33 3 88 82 77 88

SAMOA ITALIA - LARIUS
ITALY
 VIA ANTONIO STOPPANI,21
 23801 CALOLZIOCORTE (LC) ITALY
 Tel.: +39 0341 621152 - Fax: + 39 0341 621242

SAMOA FLOWTECH GMBH
 GERMANY, AUSTRIA, SWITZERLAND, THE NETHERLANDS AND GREECE
 AM OBEREICHHOLZ 4
 D - 97828 MARKTHEIDENFELD, GERMANY
 TEL.: +49 9391 9826 0 - FAX: +49 9391 98 26 50



SAMOA LTD.
UNITED KINGDOM AND REP. OF IRELAND
 ASTURIAS HOUSE - BARRS FOLD ROAD
 WINGATES INDUSTRIAL PARK
 WESTHOUGHTON, BL5 3XP, UK
 TEL.: +44 1942 850600 - FAX: +44 1942 812160

SAMOA CORPORATION
 USA AND CANADA
 90 MONTICELLO ROAD
 WEAVERVILLE, NC 28787, USA
 TEL. +1 (828) 645-2290 - FAX: +1 (828) 658 0840



©Copyright, SAMOA INDUSTRIAL, S.A.
 SAMOA Industrial, S.A. is an ISO 9001, ISO 14001 and ISO 45001 certified company.

»»» Contact us today!
 Visit www.samoaindustrial.com for more information.

OPERATING AND MAINTENAINCE MANUAL AVAILABLE IN:		
	IT	https://www.larius.com/wp-content/uploads/ZEUS_LINER_ITA.pdf
	EN	https://www.larius.com/wp-content/uploads/ZEUS_LINER_UK.pdf