



ZEUS

Electric piston
pump

www.larius.com



IT	https://www.larius.com/wp-content/uploads/ZEUS_I.pdf
EN	https://www.larius.com/wp-content/uploads/ZEUS_GB.pdf
DE	https://www.larius.com/wp-content/uploads/ZEUS_D.pdf
ES	https://www.larius.com/wp-content/uploads/ZEUS_ES.pdf
FR	https://www.larius.com/wp-content/uploads/ZEUS_F.pdf
PL	https://www.larius.com/wp-content/uploads/ZEUS_PL.pdf

LAK 35105	ZEUS motor 220V + gun
LA 35105	ZEUS motor 220V
LAK 35170	ZEUS motor 110V + gun
LA35170	ZEUS motor 110V



This manual is to be considered as an English language translation of the original manual in Italian. The manufacturer shall bear no responsibility for any damages or inconveniences that may arise due to the incorrect translation of the instructions contained within the original manual in Italian.

Due to a constant product improvement programme, the factory reserves the right to modify technical details mentioned in this manual without prior notice.

ZEUS

Electric piston pump

INDEX

A	WARNINGS	2
B	TRANSPORT AND UNPACKING	3
C	CONDITIONS OF GUARANTEE	3
D	SAFETY RULES.....	3
E	WORKING PRINCIPLE	5
F	TECHNICAL DATA	6
G	DESCRIPTION OF THE EQUIPMENT	7
H	SETTING-UP	10
I	WORKING	14
J	CLEANING AT THE END OF THE WORK	17
K	ROUTINE MAINTENANCE	21
L	PROBLEMS AND SOLUTIONS	23
M	CORRECT PROCEDURE OF DECOMPRESSION	24
N	REPLACEMENT OF THE PUMPING GROUP'S GASKETS.....	25
SPARE PARTS		
O	COMPLETE ELECTRO-MECHANICAL UNIT	32
P	BASIC HYDRAULIC BLOCK REF. 30400	34
Q	COMPLETE PUMPING ELEMENT	36
R	ELECTRICAL CONTROL - EXPLODED VIEW	38
S	CARRIAGE.....	39
T	ELECTRIC MOTOR	40
U	ELECTRICAL DIAGRAM.....	41
	DECLARATION OF CONFORMITY	45

**WE ADVISE THE USE OF THIS EQUIPMENT ONLY BY PROFESSIONAL OPERATORS.
 ONLY USE THIS MACHINE FOR USAGE SPECIFICALLY MENTIONED IN THIS MANUAL.**

Thank you for choosing a **SAMOA** product.
 As well as the product purchased, you will receive a range of support services
 enabling you to achieve the results desired, quickly and professionally.

A WARNINGS

The table below provides the meaning of the symbols used in this manual in relation to using, earthing, operating, maintaining, and repairing of this equipment.

	<ul style="list-style-type: none"> • Read this operator’s manual carefully before using the equipment. • An improper use of this machine can cause injuries to people or things. • Do not use this machine when under the influence of drugs or alcohol. • Do not modify the equipment under any circumstances. • Use products and solvents that are compatible with the various parts of the equipment, and read the manufacturer’s warnings carefully. • See the Technical Details for the equipment given in the Manual. • Check the equipment for worn parts once a day. If any worn parts are found, replace them using ONLY original spare parts. • Keep children and animals away from work area. • Comply with all safety standards.
	<ul style="list-style-type: none"> • It indicates an accident risk or serious damage to equipment if this warning is not followed.
	<p>FIRE AND EXPLOSION HAZARD</p>
	<ul style="list-style-type: none"> • Solvent and paint fumes in work area can ignite or explode. • To help prevent fire and explosion: <ul style="list-style-type: none"> - Use equipment ONLY in well ventilated area. - Eliminate all ignition sources, such as pilot lights, cigarettes and plastic drop cloths (potential static arc). - Ground equipment and conductive objects. - Use only grounded hoses. • Do not use trichloroethane, methylene chloride, other halogenated hydrocarbon solvents or fluids containing such solvents in pressurized aluminium equipment. Such use can cause serious chemical reaction and equipment rupture, and result in death, serious injury, and property damage. • Do not form connections or switch light switches on or off if the air contains inflammable fumes. • If electrical shocks or discharges are encountered the operation being carried out using the equipment must be stopped immediately. • Keep a fire extinguisher at hand in the immediate vicinity of the work area.
	<ul style="list-style-type: none"> • It indicates wound and finger squashing risk due to movable parts in the equipment. • Keep away from moving parts. • Do not use the equipment without the proper protection. • Before any inspection or maintenance of the equipment, carry out the decompression procedure explained in this manual, and prevent any risk of the equipment starting unexpectedly.
	<ul style="list-style-type: none"> • Report any risk of chemical reaction or explosion if this warning has not been given. • (IF PROVIDED) There is a risk of injury or serious lesion related to contact with the jet from the spray gun. If this should occur, IMMEDIATELY contact a doctor, indicating the type of product injected. • (IF PROVIDED) Do not spray before the guard has been placed over the nozzle and the trigger on the spray gun. • (IF PROVIDED) Do not put your fingers in the spray gun nozzle. • Once work has been completed, before carrying out any maintenance, complete the decompression procedure.
	<ul style="list-style-type: none"> • It indicates important recommendations about disposal and recycling process of products in accordance with the environmental regulations.
	<ul style="list-style-type: none"> • Mark any clamps attached to earth cables. • Use ONLY 3-wire extension cords and grounded electrical outlets. • Before starting work make sure that the electrical system is grounded and that it complies with safety standards. • High-pressure fluid from gun, hose leaks, or ruptured components will pierce skin. • To help prevent injection, always: <ul style="list-style-type: none"> - (IF PROVIDED) Engage trigger lock when not spraying. - (IF PROVIDED) Do not put your hand over the spray tip. Do not stop or deflect leaks with your hand, body or other. - (IF PROVIDED) Do not point gun at anyone or at any part of the body. - (IF PROVIDED) Never spray without tip guard. - Do pressure relief if you stop spraying or being servicing sprayer and before any maintenance operations. - Do not use components rated less than sprayer Maximum Working Pressure. - Never allow children to use this unit - (IF PROVIDED) Brace yourself; gun may recoil when triggered.
	<p>If high pressure fluid pierces your skin, the injury might look like “just a cut”, but it is a serious wound! Get immediate medical attention.</p>
	<ul style="list-style-type: none"> • It is obligatory to wear suitable clothing as gloves, goggles and face shield. • Wear clothing that complies with the safety standards in force in the country in which the equipment is used. • Do not wear bracelets, earrings, rings, chains, or anything else that may hinder the operator’s work. • Do not wear clothing with wide sleeves, scarves, ties, or any other piece of clothing that could get tangled up in moving parts of the equipment during the work, inspection, or maintenance cycles.

B TRANSPORT AND UNPACKING

- The packed parts should be handled as indicated in the symbols and markings on the outside of the packing.
- Before installing the equipment, ensure that the area to be used is large enough for such purposes, is properly lit and has a clean, smooth floor surface.
- The user is responsible for the operations of unloading and handling and should use the maximum care so as not to damage the individual parts or injure anyone. To perform the unloading operation, use only qualified and trained personnel (truck and crane operators, etc.) and also suitable hoisting equipment for the weight of the installation or its parts. Follow carefully all the safety rules. The personnel must be equipped with the necessary safety clothing.
- The manufacturer will not be responsible for the unloading operations and transport to the workplace of the machine.
- Check the packing is undamaged on receipt of the equipment. Unpack the machine and verify if there has been any damage due to transportation.

In case of damage, call immediately the Manufacturer and the Shipping Agent.

All the notices about possible damage or anomalies must arrive timely within 8 days at least from the date of receipt of the plant through Registered Letter to the Shipping Agent and to the manufacturer.

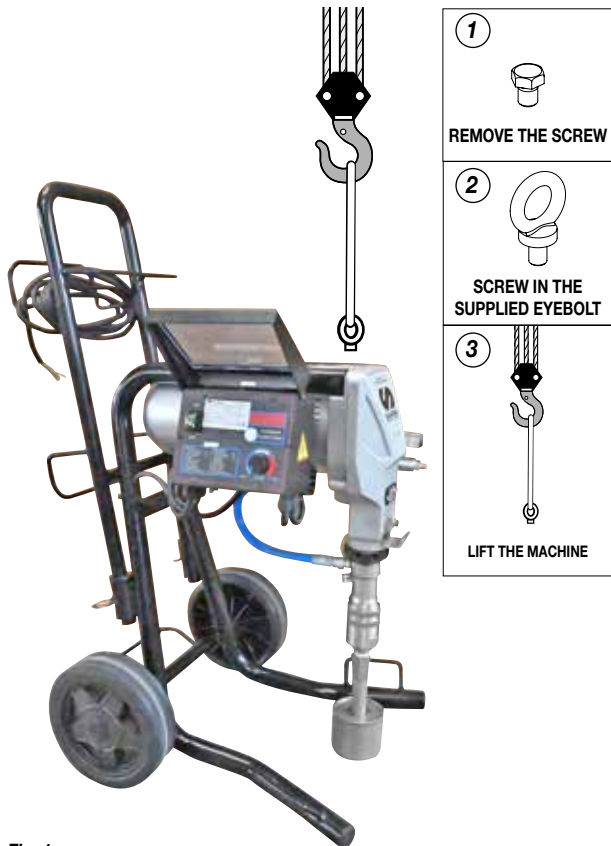

Fig. 1

LIFTING POINTS

There are no precise lifting points for the machine in its entirety. In order to determine the most appropriate lifting points, refer to the geometric characteristics of the machine itself (*proceed as shown*).



The disposal of packaging materials is a customer's competence and must be performed in accordance with the regulations in force in the country where the plant is installed and used. It is nevertheless sound practice to recycle packaging materials in an environment-friendly manner as much as possible.

C CONDITIONS OF GUARANTEE



The conditions of guarantee do not apply in the following situations:

- improper washing and cleaning of components causing malfunction, wear or damage to the equipment or any of its parts;
- improper use of the equipment;
- use that does not conform with applicable national legislation;
- incorrect or faulty installation;
- modifications, interventions and maintenance that have not been authorised by the manufacturer;
- use of non-original spare parts or parts that do not correspond to the specific model;
- total or partial non-compliance with the instructions provided.

D SAFETY RULES



Read carefully and entirely the following instructions before using the product. Please save these instructions in a safe place.



The unauthorised tampering/replacement of one or more parts composing the machine, the use of accessories, tools, expendable materials other than those recommended by the manufacturer can be a danger of accident.



The manufacturer will be relieved from tort and criminal liability.

- THE EMPLOYER SHALL TRAIN ITS EMPLOYEES ABOUT ALL THOSE RISKS STEMMING FROM ACCIDENTS, ABOUT THE USE OF SAFETY DEVICES FOR THEIR OWN SAFETY AND ABOUT THE GENERAL RULES FOR ACCIDENT PREVENTION IN COMPLIANCE WITH INTERNATIONAL REGULATIONS AND WITH THE LAWS OF THE COUNTRY WHERE THE PLANT IS USED.

- THE BEHAVIOUR OF THE EMPLOYEES SHALL STRICTLY COMPLY WITH THE ACCIDENT PREVENTION AND ALSO ENVIRONMENTAL REGULATIONS IN FORCE IN THE COUNTRY WHERE THE PLANT IS INSTALLED AND USED.
- KEEP YOUR WORK PLACE CLEAN AND TIDY. DISORDER WHERE YOU ARE WORKING CREATES A POTENTIAL RISK OF ACCIDENTS.
- ALWAYS KEEP PROPER BALANCE AVOIDING UNUSUAL STANCE.
- BEFORE USING THE TOOL, ENSURE THERE ARE NOT DAMAGED PARTS AND THE MACHINE CAN WORK PROPERLY.
- ALWAYS FOLLOW THE INSTRUCTIONS ABOUT SAFETY AND THE REGULATIONS IN FORCE.
- KEEP THOSE WHO ARE NOT RESPONSIBLE FOR THE EQUIPMENT OUT OF THE WORK AREA.
- **NEVER** EXCEED THE MAXIMUM WORKING PRESSURE INDICATED.
- (IF PROVIDED) **NEVER** POINT THE SPRAY GUN AT YOURSELVES OR AT OTHER PEOPLE. THE CONTACT WITH THE CASTING CAN CAUSE SERIOUS INJURIES.
- IN CASE OF INJURIES CAUSED BY THE GUN CASTING, SEEK IMMEDIATE MEDICAL ADVICE SPECIFYING THE TYPE OF THE PRODUCT INJECTED. **NEVER** UNDERVALUE A WOUND CAUSED BY THE INJECTION OF A FLUID.
- ALWAYS DISCONNECT THE SUPPLY AND RELEASE THE PRESSURE IN THE CIRCUIT BEFORE PERFORMING ANY CHECK OR PART REPLACEMENT OF THE EQUIPMENT.
- NEVER MODIFY ANY PART IN THE EQUIPMENT. CHECK REGULARLY THE COMPONENTS OF THE SYSTEM. REPLACE THE PARTS DAMAGED OR WORN.
- (IF PROVIDED) TIGHTEN AND CHECK ALL THE FITTINGS FOR CONNECTION BETWEEN PUMP, FLEXIBLE HOSE AND SPRAY GUN BEFORE USING THE EQUIPMENT.
- ALWAYS USE THE FLEXIBLE HOSE SUPPLIED WITH STANDARD KIT.
- THE USE OF ANY ACCESSORIES OR TOOLING OTHER THAN THOSE RECOMMENDED IN THIS MANUAL, MAY CAUSE DAMAGE OR INJURE THE OPERATOR.
- THE FLUID CONTAINED IN THE FLEXIBLE HOSE CAN BE VERY DANGEROUS. HANDLE THE FLEXIBLE HOSE CAREFULLY. DO NOT PULL THE FLEXIBLE HOSE TO MOVE THE EQUIPMENT. NEVER USE A DAMAGED OR A REPAIRED FLEXIBLE HOSE.



Avoid approaching too much to the pump piston rod when the pump is working or under pressure. A sudden movement of the piston rod can cause wounds or finger squashing.



The high speed of travel of the product in the hose can create static electricity through discharges and sparks. It is suggested to earth the equipment. The pump is earthed through the earth cable of the supply. The gun is earthed through the high pressure flexible hose. All the conductors near the work area must be earthed.



Never spray over flammable products or solvents in closed places.

Never use the tooling in presence of potentially explosive gas.

Always check that the product is compatible with the materials composing the equipment (pump, spray gun, flexible hose and accessories) with which it can come into contact. Never use paints or solvents containing Halogen Hydrocarbons (as the Methylene Chloride). If these products come into contact with aluminium parts can provoke dangerous chemical reactions with risk of corrosion and explosion.

ELECTRICAL SAFETY PRECAUTIONS

- Check the switch is on the “OFF” position before connecting the cable to the mains.
- Never carry a plugged-in equipment.
- Disconnect the equipment before storing it and before performing any maintenance operation or replacing of accessories.
- Do not carry the equipment neither unplug it by pulling the electric cable.
- Protect the cable from heat, oil and sharp edges.
- When the tool is used outdoors, use only an extension cable suited for outdoor use and so marked.
- Take care when the pumping rod is moving. Stop the machine whenever someone is within its vicinity.
- Repairs of the electrical equipment should only be carried out by skilled personnel, otherwise considerable danger to the user may result.



Never attempt to tamper with the calibre of instruments.

E WORKING PRINCIPLE

The **ZEUS** unit is defined “electric piston pump”.
An electric piston pump is used for high pressure painting without air (from this process derives the term “airless”).
The pump is controlled by an electric motor coupled with a reduction gear.
A cam shaft and a connecting rod allow to obtain the reciprocating motion necessary to the working of the “pumping group” piston.
The piston movement produces a “vacuum”.

The product is sucked, pushed towards the pump outlet and then sent to the gun through the flexible hose.
An electronic device located next to the reduction box, is used to regulate and control the pressure of the material leaving the pump.
When the pump reaches the set value, the motor stops and starts again when the value decreases.
A safety valve avoiding overpressure, guarantees the total reliability of the equipment.



Fig. 1

Fields of application	Application materials	
Indoor	Top-coat plaster	Intumescent
Outdoor	Self-levelling plasters	Encapsulators
Industrial buildings	Fillers	Insulation
Industrial constructions	Stuccos	Water proofing
Redeveloping	Plasters	Elastomers
Roofing	Pre-mixed plasters (granulometry 0,0)	Epoxi resins Bitumen

COD.	MOTOR	HOSE	GUN
35170	110 V		
K35170	110 V	•	Cod. 11255
35105	220 V		
K35105	220 V	•	Cod. 11255

F TECHNICAL DATA

	ZEUS
Version	Trolley
Max. delivery	4 l/m
Max. working pressure	220 bar
Motor power	2 Kw
Voltage	110 VAC
	220 VAC
Weight	58 Kg
Max. nozzle size	0,031" Paint
	0,033" Stucco

	ZEUS
Power generation	5 Kw single phase
Material outlet	1/4" NPT-NPSM
Livello pressione sonora	≤60 dB (A)
Length (A)	560 mm
Width (B)	945 mm
Height (C)	1040 mm
Minimum encumbrance (D)	790 mm

PARTS OF THE PUMP IN CONTACT WITH THE MATERIAL:
 Stainless Steel AISI 420B, PTFE; Aluminium, Galvanised steel

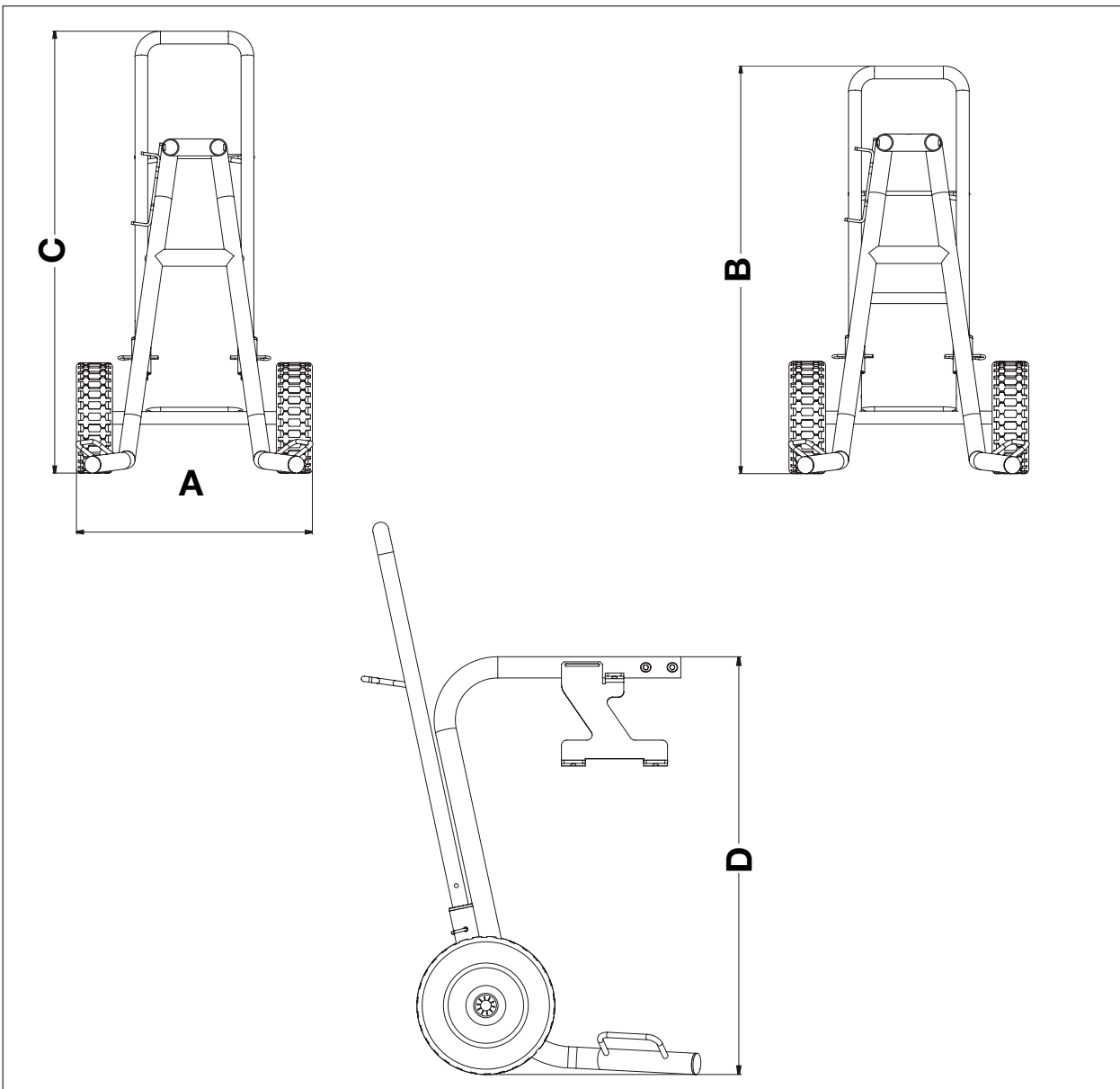

Fig. 1

D DESCRIPTION OF THE EQUIPMENT

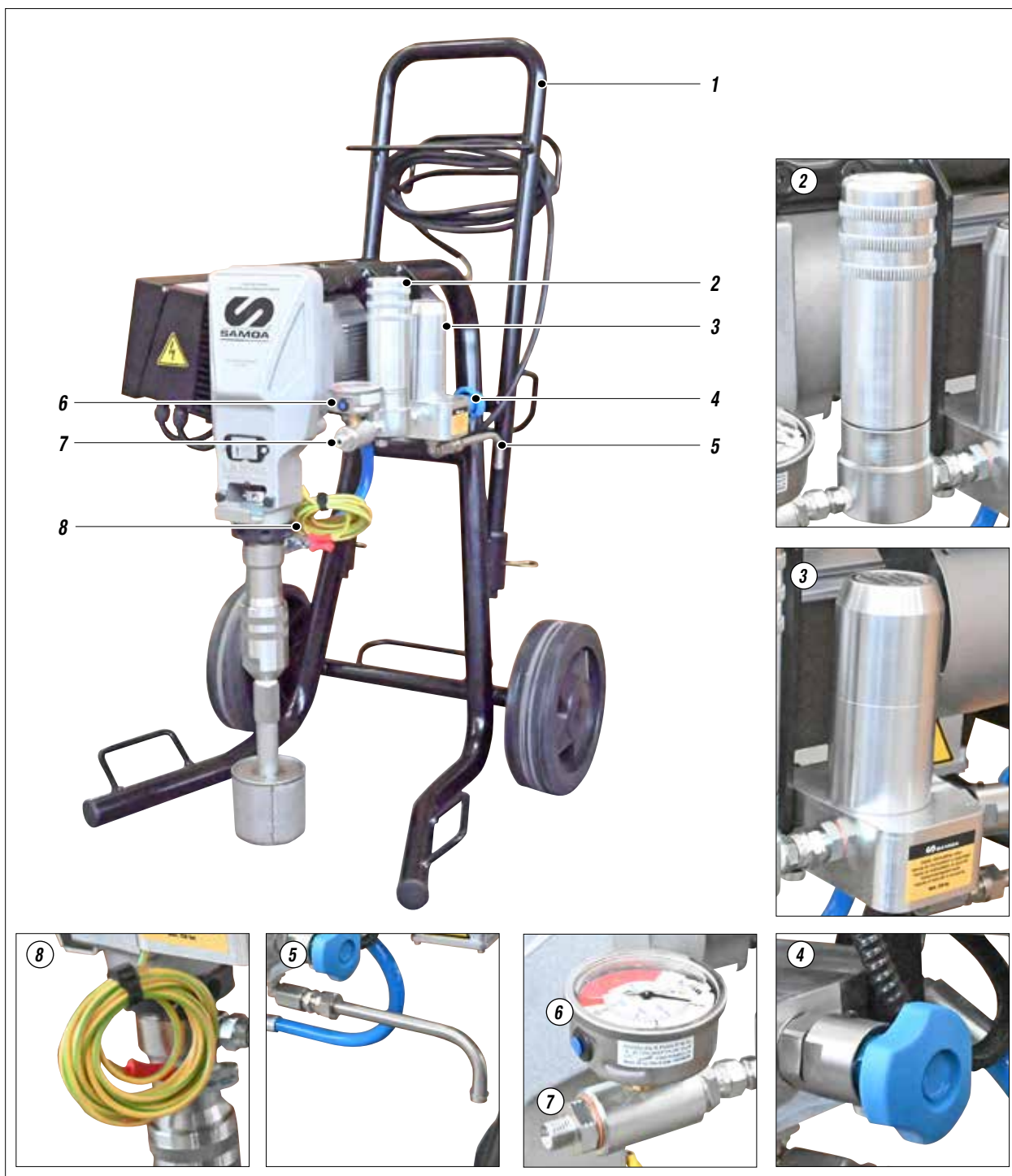

Fig. 1

Pos.	Description
1	Carriage
2	Line filter
3	Pressure transmitter
4	Recirculation valve

Pos.	Description
5	Recirculation tube
6	Manometer
7	Flexible pipe connection
8	Earth cable

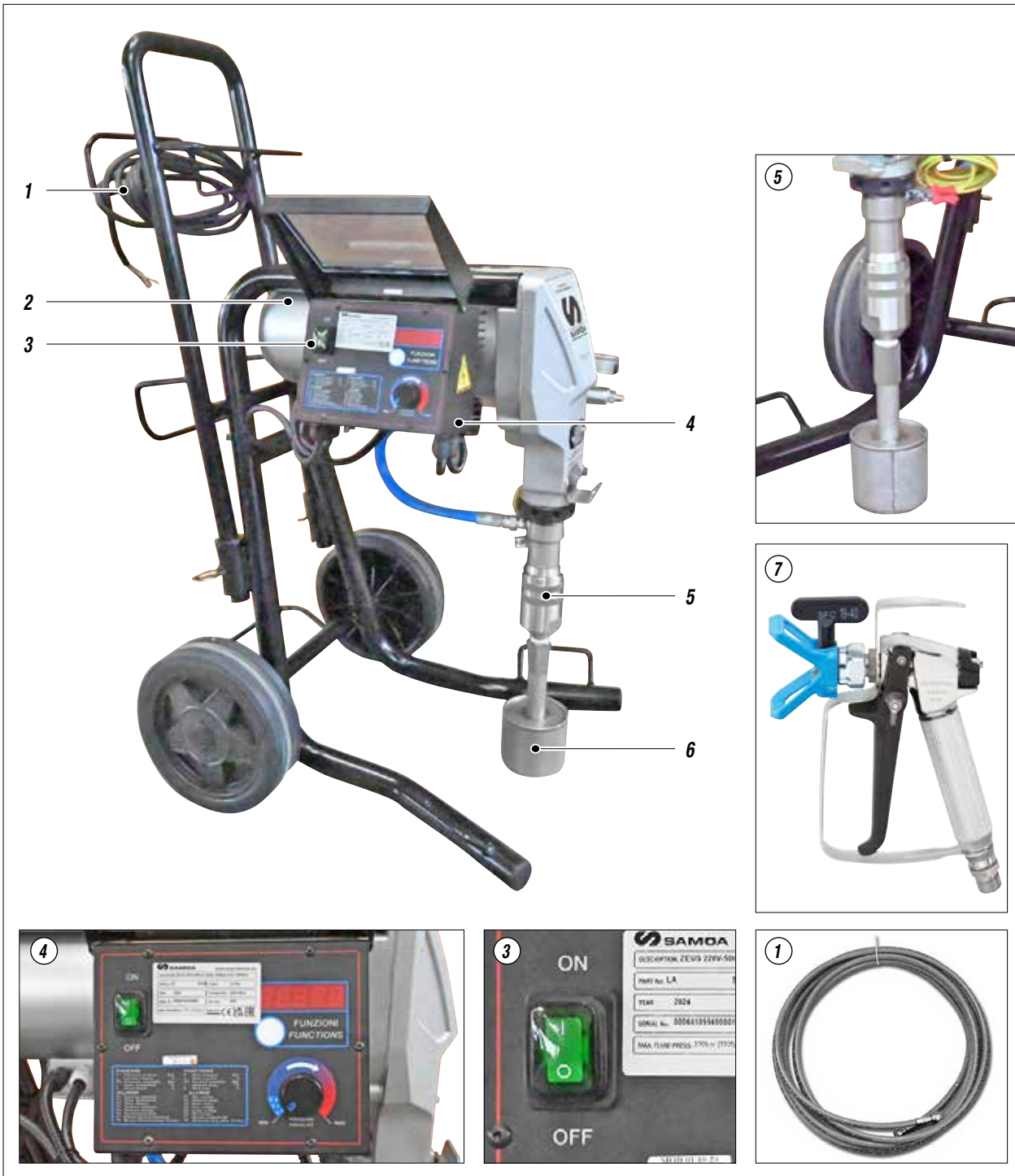

Fig. 1

Pos.	Description
1	High pressure flexible pipe
2	Electric motor
3	ON/OFF switch
4	Control equipment

Pos.	Description
5	Pumping group
6	Filtro di aspirazione
7	Airless manual gun AT250

ALARM MESSAGES

When the product to be applied is finished the pump “sucks air” and automatically switches to the minimum number of cycles. The alarm messages function is described on the area sign (6).

Each time key (8) is pushed, the messages are displayed on the screen (7).



When an alarm message has been indicated the machine has to be switched off and on again using switch (1).

Each time the machine is switched off, the condensers remain charged for about 5 minutes. To avoid risk of shock, when removing the electrical box wait until the condensers have discharged altogether.



Fig. 3

Pos.	Description
1	ON/OFF switch
2	Work pressure adjustment knob
3	Maximum pressure
4	Minimum pressure

Pos.	Description
5	Material circulation and machine washing position
6	Alarms
7	Message screen
8	Function keys

FUNCTIONS TABLE

Function symbol	Type of function	Description of function
P	Working pressure (bar)	Indicates the real time pressure used during the work cycle
J	Motor current (A)	Indicates the real time amperage on the equipment's motor during the work cycle
Pd	Pressure setting (bar)	Indicates the pressure set before the work cycle begins
c	Dissipator temp. (°C)	Indicates the dissipator temperature (in degrees Centigrade) during the work cycle
h	Working hours (h)	Indicates the total number of hours the equipment has worked

ALARM MESSAGE TABLE

Alarm symbol	Type of alarm	Cause	Solution
F1	Maximum current	The motor's current absorption is too high	Check the mechanical and hydraulic condition of the equipment. If necessary, take action
F2	Dissipator temp.	The dissipator temperature is too high	Check that the dissipator surfaces are clean and that the dissipator is properly ventilated
F3	Motor temp.	The motor temperature is too high	Check that the motor's heat dissipation surfaces are clean. Check that cooling ventilation is correct
F4	Maximum voltage	The voltage is too high	Check the connection to the electrical line and reinstate the correct nominal voltage
F5	Minimum voltage	The voltage is too low	Check the connection to the electrical line and reinstate the correct nominal voltage
F6	Earth connection	The earth connection is disconnected or non-existent	Check the earth cable and, if necessary, replace it. Make sure that the machine is earthed
F7	Pressure sensor missing	The pressure sensor is damaged or not fitted	Replace it
F8	Automatic switch-off during circulation phase (15 minutes)	The equipment is in cleaning mode	Wait until the equipment has stopped completely before using it for a new job

H SETTING-UP

CONNECTION OF THE FLEXIBLE HOSE TO THE GUN

- Connect the high pressure flexible hose (1) to the pump (2) and to the gun (3), ensuring to tighten the fittings (*the use of two wrenches is suggested*).

NEVER use sealants on fittings' threads.

It is **ADVISED** to mount a high pressure manometer at the pump outlet (*see on page "Accessories"*) to read the product pressure.

- It is recommended to use the hose provided with the standard kit (*ref. 18036*). **NEVER** use a damaged or a repaired flexible hose.

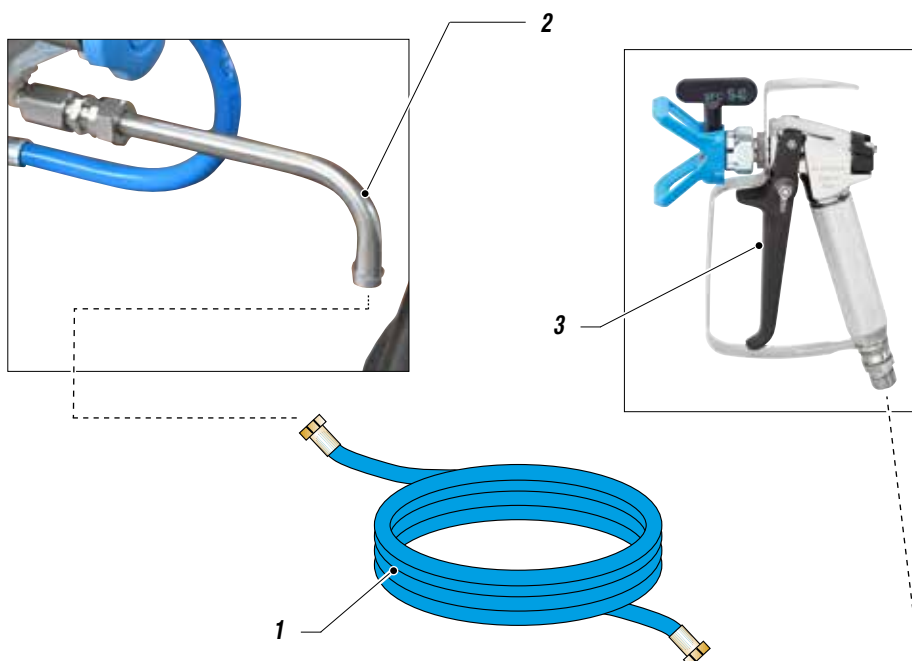

Fig. 1

Fig. 1

CHECK ON POWER SUPPLY



Make sure that the electrical system is earthed and complies with regulations.

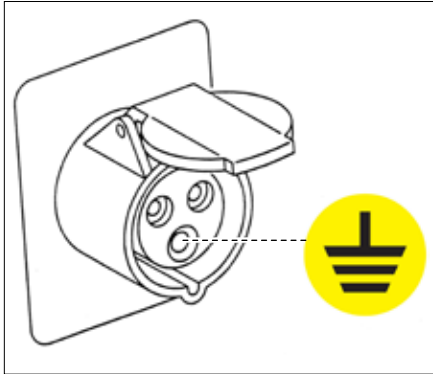
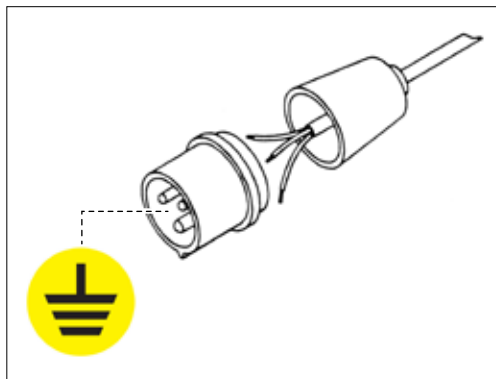

Fig. 2

- Check the mains voltage corresponds to the equipment's rating.
- The supply cable is provided without plug. Use a plug which guarantees the plant earthing. Only a technician or a skilled person should perform the connection of the plug to the electric cable.



Should anyone use an extension cable between the tooling and the socket, it must have the same characteristics as the cable supplied (*minimum diameter of the wire 4 mm²*) with a maximum length of 50 mt. Higher lengths and lower diameters can provoke excessive voltage falls and also an anomalous working of the equipment.

ZEUS equipment is fitted with an additional external earth cable that is connected to the stem on the pump unit by means of a specific clamp (4), in order to protect the operator against any risk of static or electric shock.



Fig. 4

To avoid electric shock when disassembling or checking the electronic equipment, wait 5 minutes after having disconnected the power supply cable, so that the electricity stored in the condensers while working can be dissipated.

Also check the condition of the earth cable to avoid any risk of shock.



Before carrying out any checks on the machine (*maintenance, cleaning, or replacing parts*) switch off the machine and wait until it has stopped altogether.





While checking stay away from electrical or moving parts to avoid any risk of shock or crushing of hands.



WARNING :

- **DO NOT** modify the plug for the earth socket in any way.
- **ONLY** use electrical connections that are earthed.
- Make sure that any earth extension cords are in good condition.
- **ONLY** use three-core extension cables.
- **Avoid direct contact with the rain. Keep the equipment in a dry place.**

CONNECTION OF THE TOOLING TO THE POWER SUPPLY

 Before connection up the power supply to the equipment, make sure that the electrical system is earthed and complies with regulations.  Make sure that the clamp (4) provided is positioned correctly, in order to earth the pump unit in the equipment properly.

- Check the switch (5) is on the “OFF” (0) position before connecting the cable to the mains.
- Place the pressure control knob (H6) on the “MIN” position (turn counterclockwise).

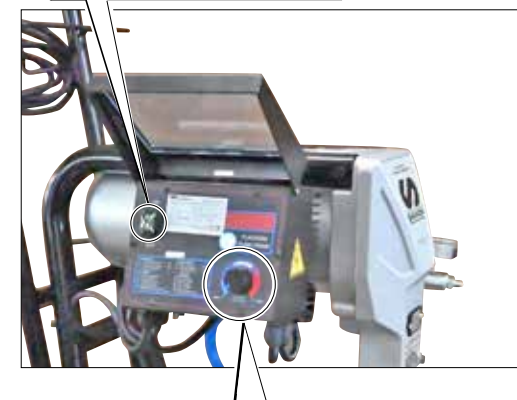
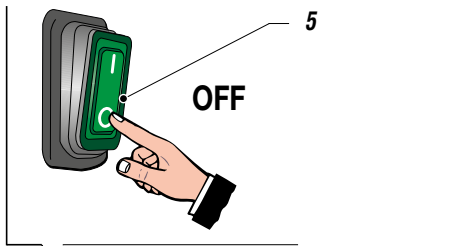

Fig. 5

WASHING OF THE NEW EQUIPMENT

- The equipment has already been adjusted at our factory with light mineral oil left inside the pumping group as protection. Therefore, wash with diluent before sucking the product.

- Lift the suction unit and immerse it in the bucket that contains the washing liquid.



Fig. 6

- Ensure the gun is without nozzle (3).



Fig. 7

- Press the switch (5) of the equipment “ON” (I).



Fig. 8

- Turn the pressure setting knob (6) clockwise to the "CIRCULATION & WASHING" position (drop symbol).

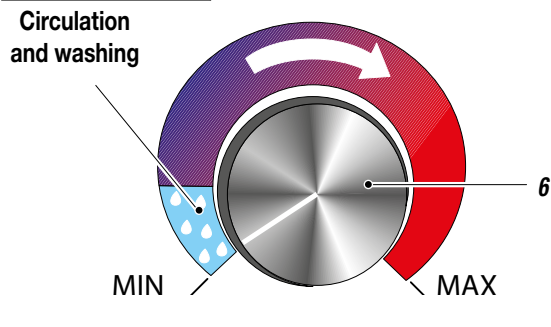

Fig. 9



Hold the spray gun against the edge of the metal contained (7).

- Point the spray gun into the collection container (7) and hold the trigger down (in order to expel the oil contained) until clean liquid flows out.
Now, release the trigger.



Use a metal container (7).
To avoid any risk of electric shock connect the collection container to a surface that is earthed (e.g. concrete) and not to surfaces that will insulate the container from the earth.



- Remove the suction hose and remove the bucket of cleaning liquid.
- Now point the spray gun (8) into the container (7) and press the trigger to recover any cleaning liquid left.
- As the pump idles, press the "OFF" (0) switch (H5) to stop the tooling.
When this is complete, release the trigger.

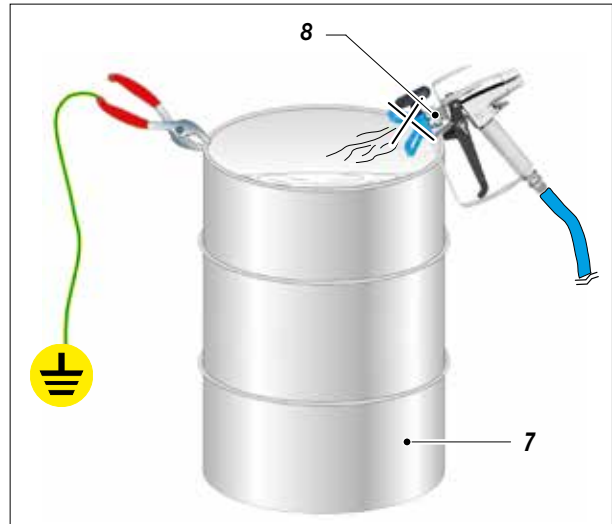

Fig. 10



Absolutely avoid to spray solvents indoors. In addition, it is recommended to keep away from the pump in order to avoid the contact between the solvent fumes and the electric motor.



For disposing of the washing liquid, see the requirements laid down in the Standards in force in the country in which the equipment is used and act accordingly.

The Client is solely responsible for any irregular action taken before, during, or after disposing of washing liquid, or in interpreting and applying the current Standards in this regard.

- Now the machine is ready. When water-based paint has been used, in addition to washing using the cleaning liquid, we recommend washing with soapy water and then clean water.

PREPARING THE PRODUCT



MAKE SURE THE PRODUCT IS SUITABLE TO BE USED WITH AN AIRLESS SPRAY GUN.

- Mix and filter the product before using it.



Make sure the product to be used is compatible with the materials employed for manufacturing the equipment (stainless steel and aluminium). Because of that, please contact the supplier of the product.

Never use products containing halogen hydrocarbons (as *methylene chloride*). If these products come into contact with aluminium parts of the equipment, can provoke dangerous chemical reactions with risk of explosion.



REMOVE THE FILTER (H9) FOR DENSE PRODUCTS.



Fig. 11

I WORKING

START OF THE WORKING OPERATIONS



Make sure that the electrical system is earthed and complies with regulations.
 Make sure that the earth clamp is positioned correctly to ensure a safe earth on the pump unit.

- Use the tooling after performing all the **SETTING UP** operations above described.
- Dip the suction pipe (1) into the product tank.

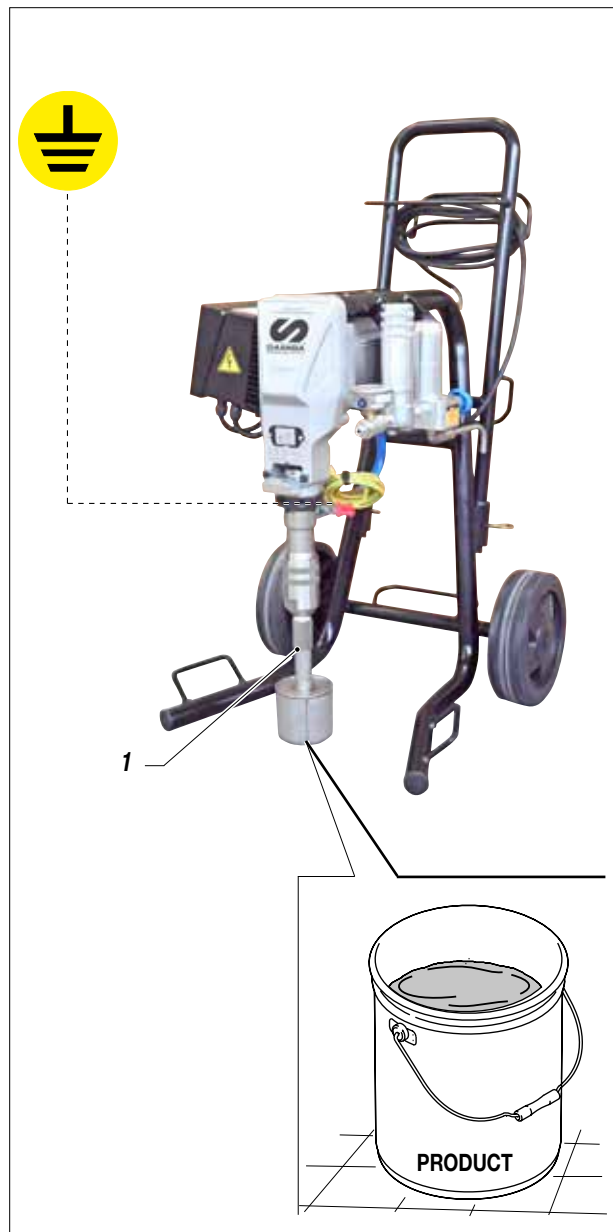

Fig. 1

- Open the recirculation - safety valve (2).

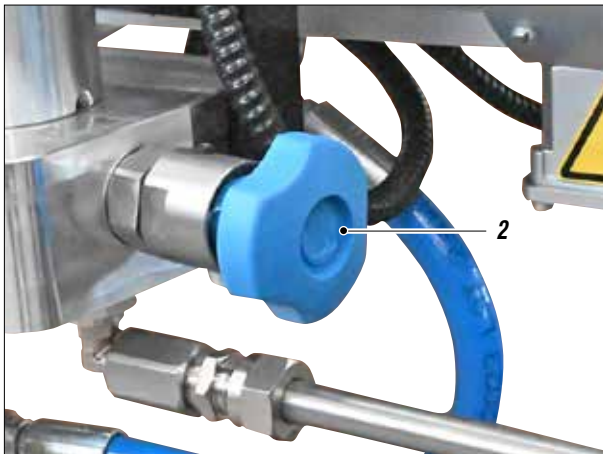

Fig. 2

- Press the switch (3) of the equipment "ON" (I).

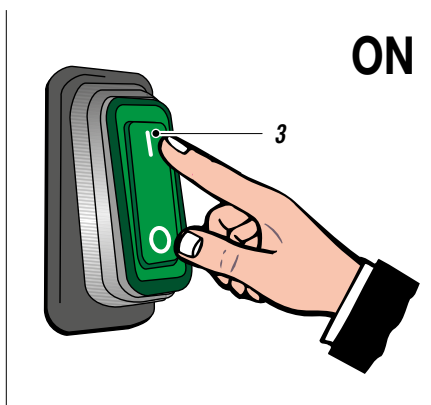

Fig. 3

- Turn the pressure setting knob (4) clockwise to the "CIRCULATION & WASHING" position (drop symbol).

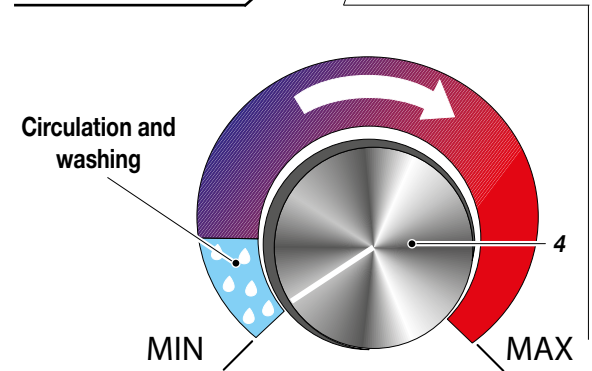

Fig. 4

- Make sure that the product circulates regularly from the circulation hose (5).
- Close the recirculation - safety valve (2).

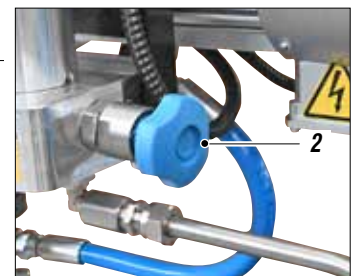
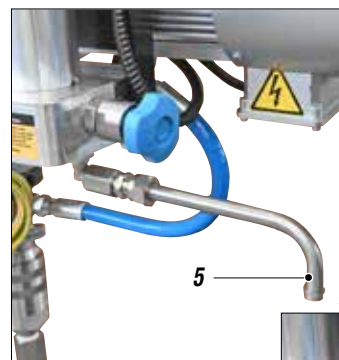

Fig. 5

- The machine continues to suck up product until it has filled the hose as far as the spray gun, after which it will automatically stop when the set pressure is reached.

SPRAY ADJUSTMENT

- Slowly turn clockwise the pressure control knob (4) to reach the pressure value in order to ensure a good atomization of the product.



Fig. 6

- An irregular and marked spray on the sides indicates a low working pressure. On the contrary, a too high pressure causes a high fog (“overspray”) and waste of product.
- In order to avoid overthickness of paint, let the gun advance sideways (*right-left*) when spraying.
- Always paint with regular parallel bands coats.
- Keep a safety and constant distance between the gun and the support to be painted and also keep yourselves perpendicular to it.

NEVER point the spray gun at yourselves or at other people. The contact with the casting can cause serious injuries.

In case of injuries caused by the gun casting, seek immediate medical advice specifying the type of the product injected.

Safety valve: when working at the maximum pressure available, releasing the gun trigger sudden increases of pressure can occur. In this case, the safety valve (5) opens automatically eliminating part of the product from the recirculating tube (16). Then it closes so as to go back to the first working conditions.

The valve (5) serves two purposes:

- Safety: It opens the passage at pressure peaks exceeding 280-300 bar;
- Regulation: It returns the working pressure to 230 bar and levels out the hydraulic operating hysteresis.

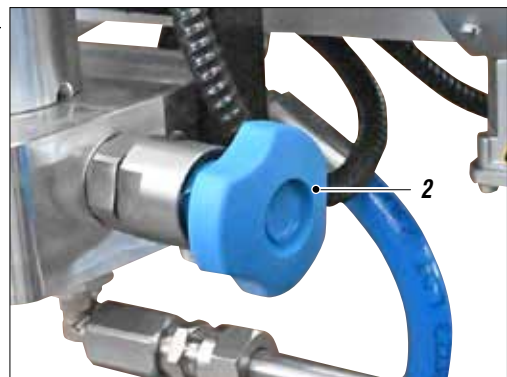
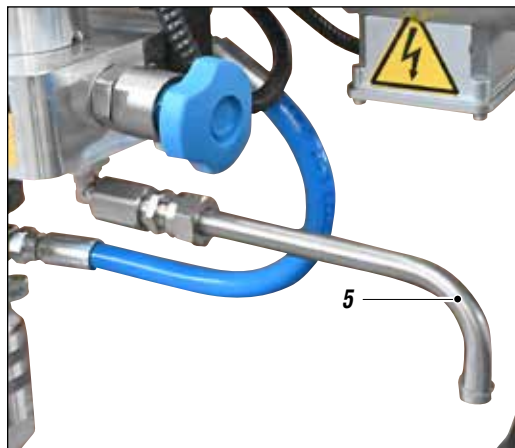

Fig. 7

J CLEANING AT THE END OF THE WORK

CLEANING FOR SOLVENT-BASED PRODUCTS



Make sure that the electrical system is earthed and complies with regulations.

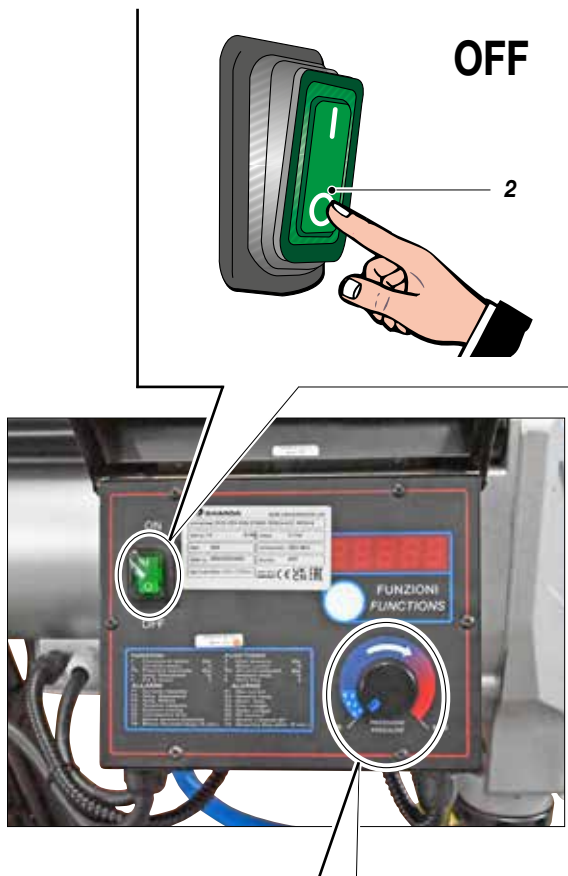

Fig. 1

- Hold the spray gun trigger down.
- Open the recirculation - safety valve (3) to release the pressure in the circuit.

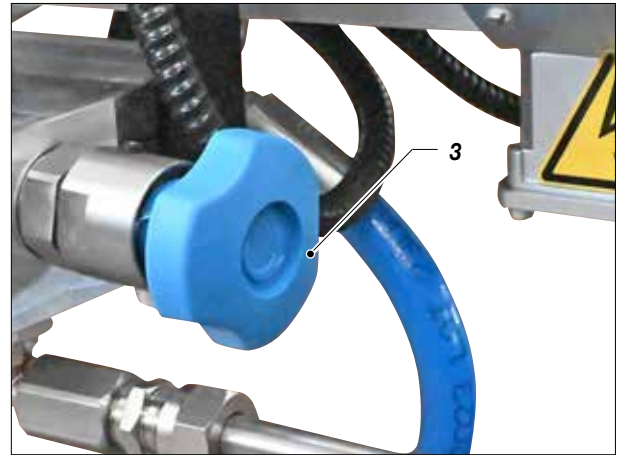

Fig. 2

- Lift the suction hose and replace the bucket containing the product with a bucket of cleaning liquid (make sure it is compatible with the product you are using).
- Unscrew the nozzle on the spray gun (remember to clean it with cleaning liquid).
- Press the switch (2) "ON" (I) of the equipment.



Fig. 3

- Turn the pressure setting knob (1) clockwise to the “CIRCULATION & WASHING” position (drop symbol).

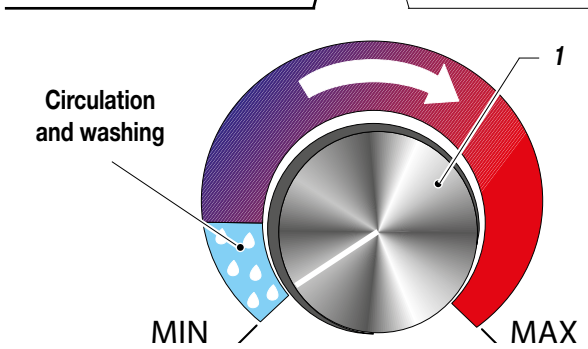



Fig. 4

- Make sure that the product circulates through the circulation hose.

 **Make sure that the machine sucks in clean washing liquid. Allow the cleaning liquid to discharge into another container and do not mix it with the cleaning liquid still to be used. We recommend circulating the cleaning liquid for at least 15 minutes.**

 **For disposing of the washing liquid, see the requirements laid down in the Standards in force in the country in which the equipment is used and act accordingly. The Client is solely responsible for any irregular action taken before, during, or after disposing of washing liquid, or in interpreting and applying the current Standards in this regard.**

- Close the recirculation - safety valve (3).

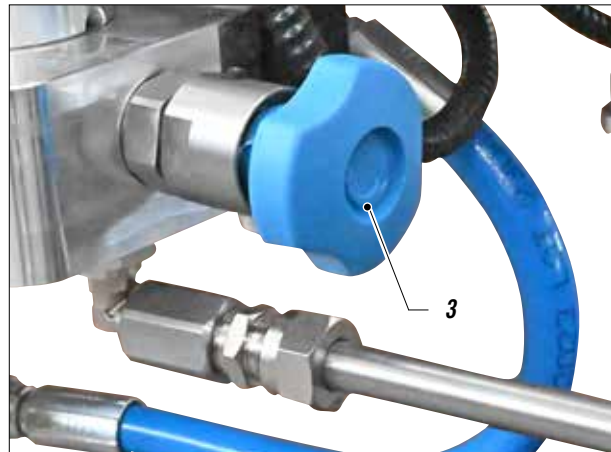



Fig. 5

- Point the spray gun (4) into the container (5) used to collect the cleaning liquid and hold the trigger down to expel any product remaining, until clean liquid flows out. Now, release the trigger.

 **Hold the spray gun against the edge of the metal contained (5).**

 **Use a metal container (5). To avoid any risk of electric shock connect the collection container to a surface that is earthed (e.g. concrete) and not to surfaces that will insulate the container from the earth.**

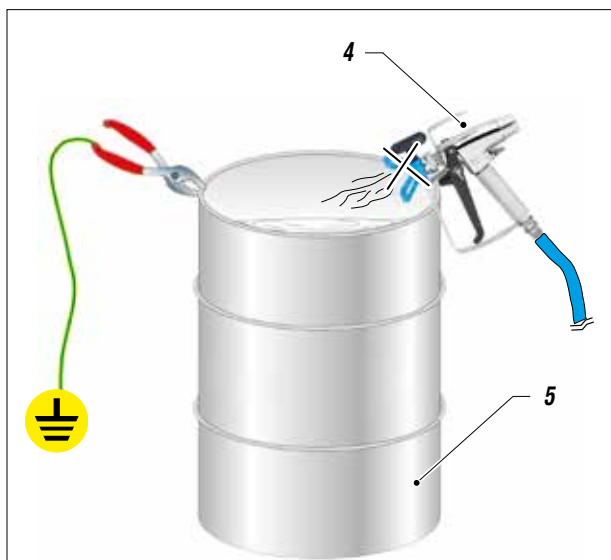

Fig. 6

- Lift the suction hose and remove the bucket of cleaning liquid.
- Now point the spray gun (J4) into the container (J5) and press the trigger to recover any cleaning liquid left.

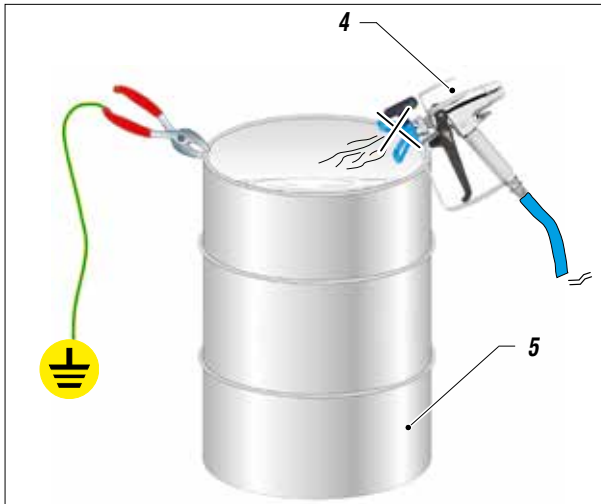
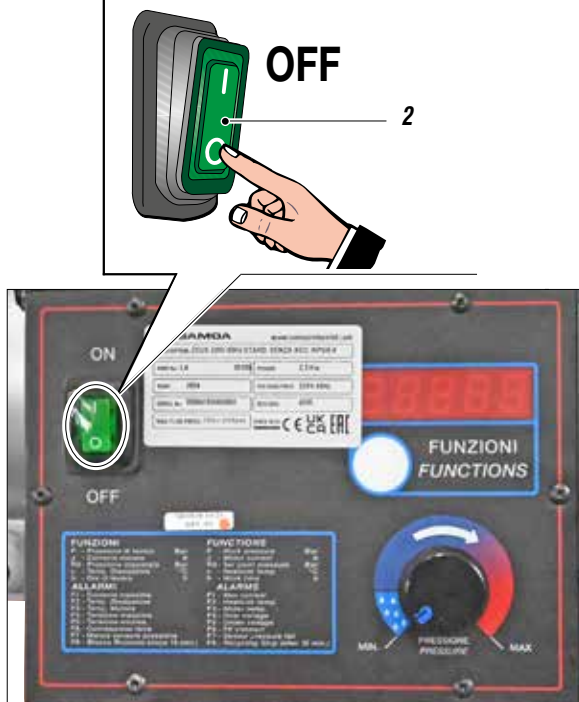

Fig. 7

- As the pump idles, press the “OFF” (0) switch (2) to stop the tooling.



- In case of long storage, we recommend you to suck and to leave light mineral oil inside the pumping group and the flexible hose.



Follow the washing procedure before using again the equipment.

- Take the cleaning liquid and store it in suitable containers.



Make sure that the machine sucks in clean washing liquid. Allow the cleaning liquid to discharge into another container and do not mix it with the cleaning liquid still to be used. We recommend circulating the cleaning liquid for at least 15 minutes.

CLEANING FOR WATER-BASED PRODUCTS



Make sure that the electrical system is earthed and complies with regulations.

- Reduce pressure to the minimum (turn counterclockwise the pressure control knob (1)).

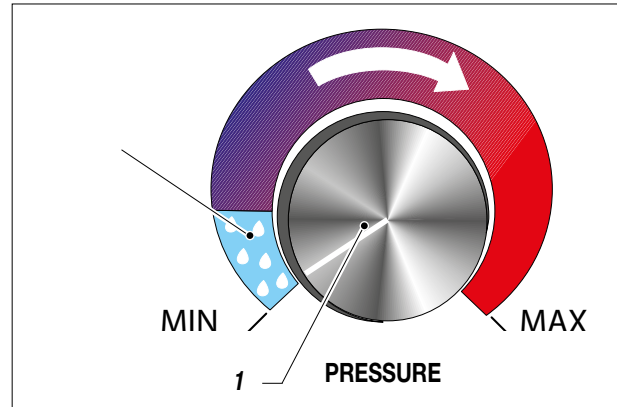

Fig. 9

- Press the switch (2) “OFF (0)” placed on the box of the electric motor, to stop the equipment.

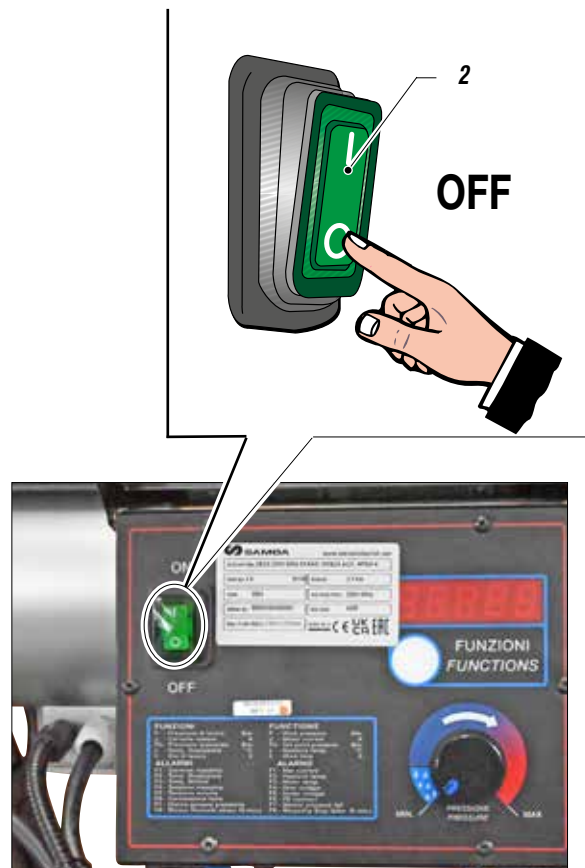

Fig. 10

- Hold the spray gun trigger down.
- Open the circulation - safety valve (3) to discharge the pressure in the circuit.

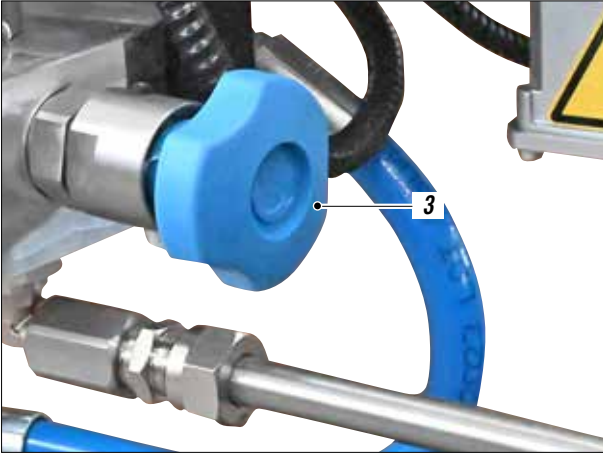

Fig. 11

- Lift the suction hose and replace the bucket of product with an empty bucket (6).
- Connect a rubber hose (7) to a water tap (8) and fill the bucket (6).
- Position an empty bucket to collect the water (9) under the circulation hose (10).



Fig. 12

- Press the switch (2) su ON (I) and turn a little the pressure control knob (1) clockwise so as the machine works till the motor starts.



Fig. 13

- Run the pump's washing cycle until clean water flows out of the circulation hose (10).
- Close the recirculation - safety valve (3).

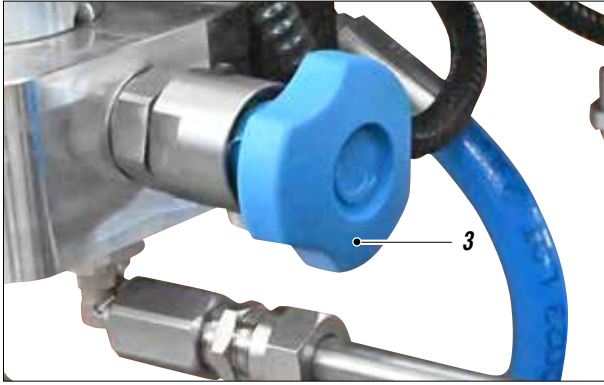

Fig. 14

- Remove the suction hose and the rubber hose and take away the bucket of water.
- Now point the spray gun (4) into the container (5) and press the trigger to recover any cleaning liquid left.



Fig. 15

- As the pump idles, press the “OFF” (0) switch (2) to stop the tooling.

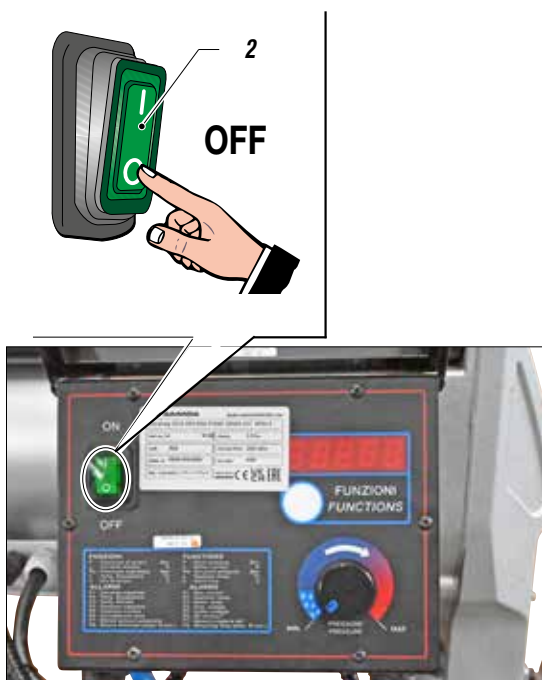

Fig. 16

- In case of long storage, we recommend you to suck and to leave light mineral oil inside the pumping group and the flexible hose.



Follow the washing procedure before using again the equipment.



If the equipment is to be stopped for a lengthy period of time, carry out the cleaning operations described previously, according to the type of product used. In case of short stoppages, suck in some water and leave the pump unit in the bucket (6) for a few minutes.

K ROUTINE MAINTENANCE

CHECK ON THE PACKING NUT

The gaskets do not need adjusting. The ring nut is only used to fit and remove gaskets and for topping up the oil.



Always disconnect the electrical supply and discharge the pressure in the pump unit (*open the discharge valve*) before carrying out any maintenance.

Wait 30 seconds before proceeding with maintenance operations to allow any residual electricity to be discharged.

- Use the lubricant (1) provided (*ref. 16340*) to make it easier to slide the piston inside the seal pack and to substitute the air with oil.



At the start of each working day check that the ring nut is full of hydraulic oil (*Ref. 16340*). This oil makes it easier for the piston to slide and prevents any material that escapes via the seal gasket drying when the equipment is stopped.



Fig. 1

- The ring nut (2) must be tightened all the way. Every 100 working hours, with the pressure at 0 bar, check that it is tightened all the way.
- The supplied pin (3 – ref. 20144) also serves the purpose of closing and opening the pump unit's locking ring-nut (4). This ring nut must always be closed in order to act as a locking counter-nut.

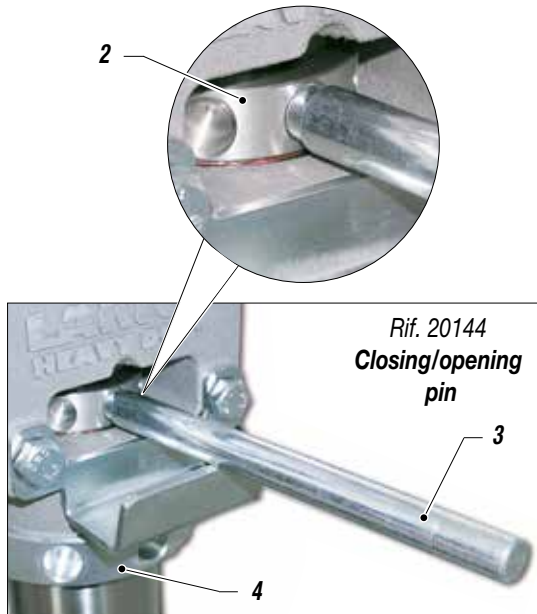

Fig. 2

CHECKING THE HEAT EXCHANGE RADIATOR

Always keep the heat exchange radiator (5) on the electronic control box clean, in order to guarantee correct heat exchange with the ambient air. We suggest cleaning using a jet of compressed air.

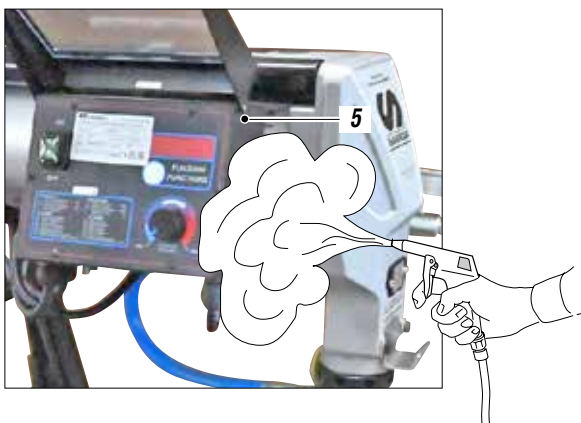

Fig. 3

PRESSURE SWITCH SEAL CHECK

Check that no material is escaping from the safety hole (6) at the bottom of the protective container. If necessary, replace the O-Ring for the pressure sensor (7).



Fig. 4

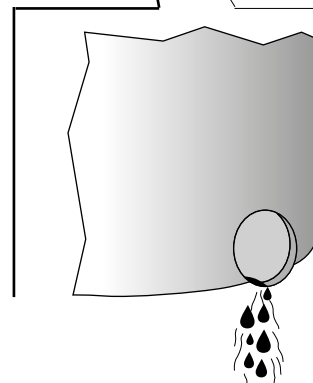
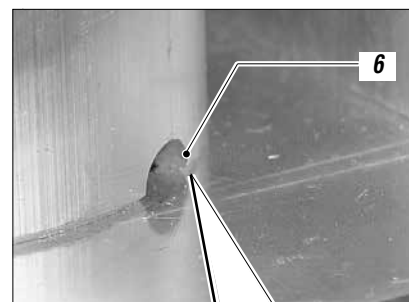

Fig. 5

L PROBLEMS AND SOLUTIONS

Problem	Cause	Solution
The equipment does not start	Lack of voltage;	Check the correct connection to the power supply;
	Considerable drops in mains voltage;	Check the extension cable;
	On/Off switch disconnected;	Ensure the On/Off switch is on the “on” position and turn clockwise the pressure control knob;
	Breakdown of pressure transmitter;	Verify and replace it, if necessary;
	Breakdown of motor electric control box;	Verify and replace it, if necessary;
	The line of material coming out of the pump is already under pressure;	Open the drain valve to release pressure in the circuit;
	The product is solidified inside the pump;	Open the drain valve to release pressure in the circuit and stop the machine. Disassemble the pumping group and the pressure transmitter and clean;
The equipment does not suck the product	Suction filter clogged;	Clean or replace it;
	Suction filter too fine;	Replace it with a larger-mesh filter (with very dense products, remove the filter);
	The equipment sucks air;	Check the suction pipe;
The equipment sucks but does not reach the pressure desired	Lack of product;	Add the product;
	The equipment sucks air;	Check the suction pipe;
	The drain valve is open;	Close the drain valve;
	The gaskets of the pumping group are worn;	Replace the gaskets;
	Suction or delivery valve dirty;	Disassemble the pumping group;
When pressing the trigger, the pressure lowers considerably	Nozzle too big or worn;	Replace it with a smaller one;
	The product is too dense;	Dilute the product, if possible;
	The filter of the gun-but is too fine;	Replace it with a larger-mesh filter;
The pressure is normal but the product is not atomized	The nozzle is partially clogged;	Clean or replace it;
	The product is too dense;	Dilute the product, if possible;
	The filter of the gun-but is too fine;	Replace it with a larger-mesh filter;
The atomization is imperfect	The nozzle is worn;	Replace it;

Problem	Cause	Solution
When releasing the trigger of the gun, the equipment does not stop (the motor runs slowly and the piston rod keeps on going up and down)	The gaskets of the pumping group are worn;	Replace the gaskets;
	Suction or delivery valve dirty;	Disassemble the pumping group and clean;
	Drain valve defective;	Verify and replace it, if necessary;
Material escaping from the cap	Material leaking from the O-Ring.	Replace the O-Ring.



Always close the air compressed supply and unload the plant pressure before performing any check or replacement of pump parts (see "correct procedure of decompression").

M CORRECT PROCEDURE OF DECOMPRESSION



Make sure that the electrical system is earthed and complies with regulations.

- Zero the pressure regulator knob.
- Move the switch (1) to the OFF (0) position to stop the equipment.

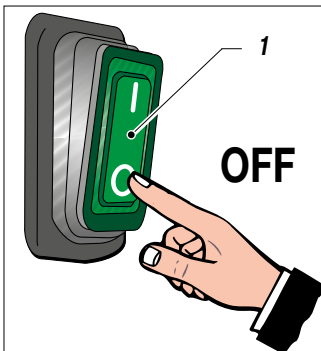

Fig. 1

- Open the circulation - safety valve (2) to discharge the residual pressure, always turning it anticlockwise.

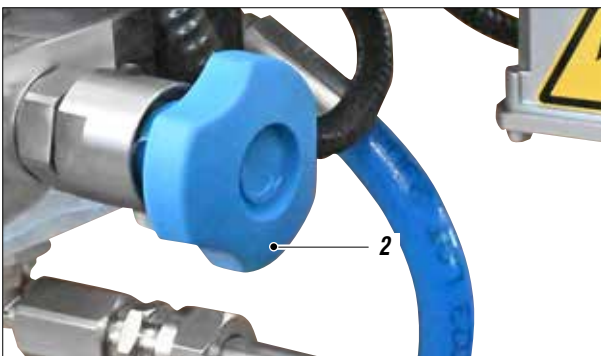

Fig. 2

- Point the gun at the tank (3) of the product and press the trigger to release pressure. At the end of the operation, insert the gun clamp (4).



Fig. 3

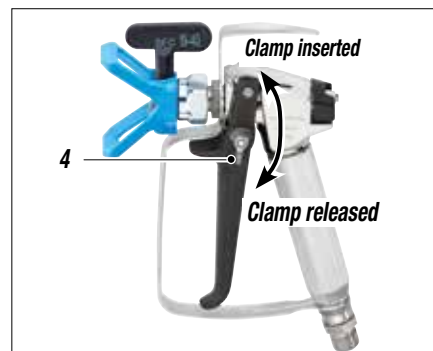

Fig. 4



WARNING :

If the equipment is still under pressure after performing the operations above described because of the nozzle or the flexible hose clogged, proceed as follows:



- Loosen very slowly the gun nozzle.
- Release the clamp.
- Point the gun at the container of the product and press the trigger to release pressure.
- Loosen very slowly the fitting of connection from the flexible hose to the gun.
- Clean or replace the flexible hose and the nozzle.

N REPLACEMENT OF THE PUMPING GROUP'S GASKETS

Each time you use the machine, check for material leaking from the top of the ring nut.

If any material leaks out when the pump is working at the set pressure, proceed as follows:

- Carry out this operation after cleaning the tooling.



Always disconnect the power supply and release pressure before going on with the operations (follow the "correct procedure of decompression").



The gaskets are self-adjusting. If a leak occurs they must be replaced.

- Disconnect the product feed hose (1) from the pump unit by unscrewing the nut (2).
- Unscrew the fixing ring nut (3) using the relevant closing pin (Ref. 20144).

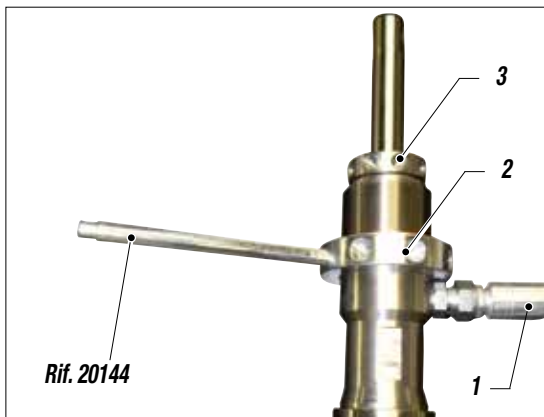

Fig. 1

- Release the plastic cover (4).

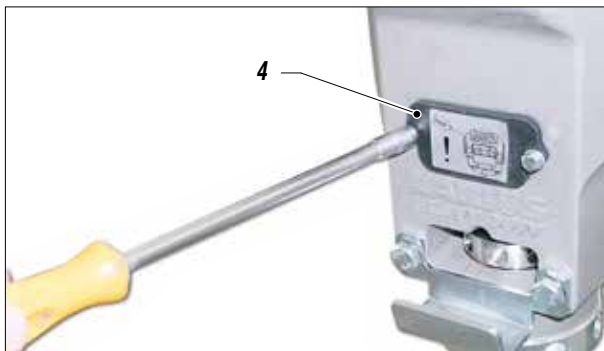

Fig. 2

- Turn the motor (6) with a screwdriver (5) until the piston rod has moved to the lowest point of its stroke.

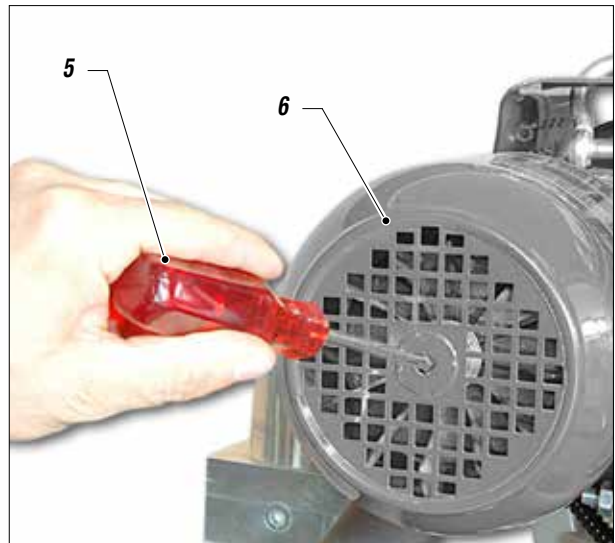

Fig. 3

- Screw the appropriate supplied tool (7 - ref- 20213) into the threaded hole on the holding pin (8).



Fig. 4

- Remove the pin (8) from its seating.

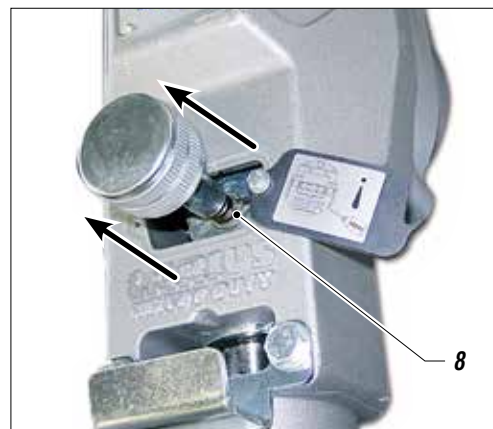

Fig. 5

- Unscrew the pump unit (9) from the frontal flange (10).



Fig. 6

PIT STOP MAINTENANCE

Replacement of upper and lower gaskets 20 minutes.

- Lock the pump unit into a vice and unscrew it with a 50mm wrench;
- Release the pump unit from the body of the suction valve;

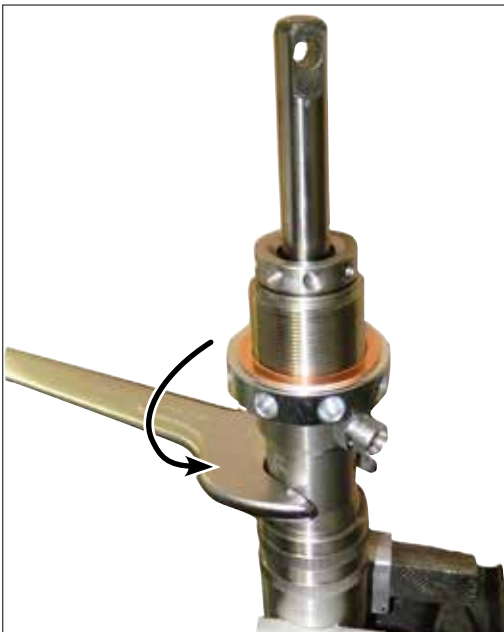

Fig. 7

Lower seal

- Remove the piston stem (11) and remove the pump unit sleeve (12);

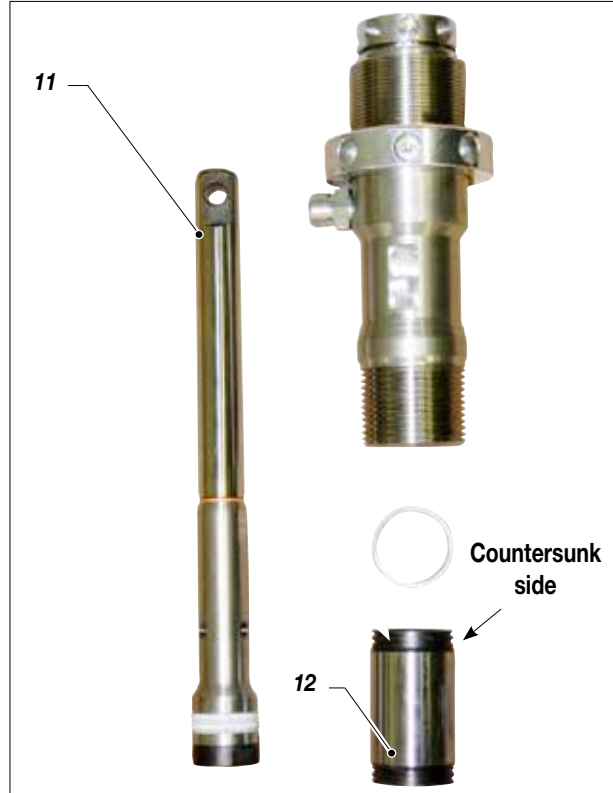

Fig. 8

- Grip the stem valve (13) in a vice;



Fig. 9

- Use a size 22 spanner to unscrew the lower stem (14);

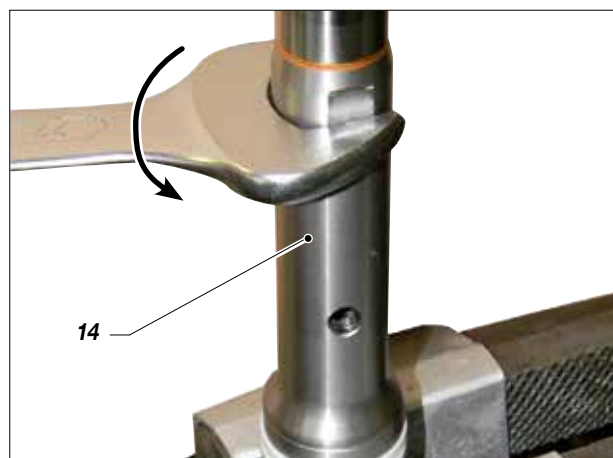

Fig. 10

- Unscrew the component (15);



Fig. 11

- Unscrew the stem valve (16)

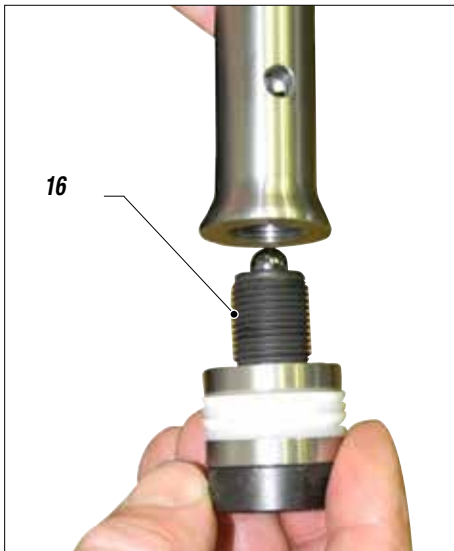

Fig. 12

- Check the surface of the ball seating (17) that comes into contact with the ball (18). If worn, replace them;

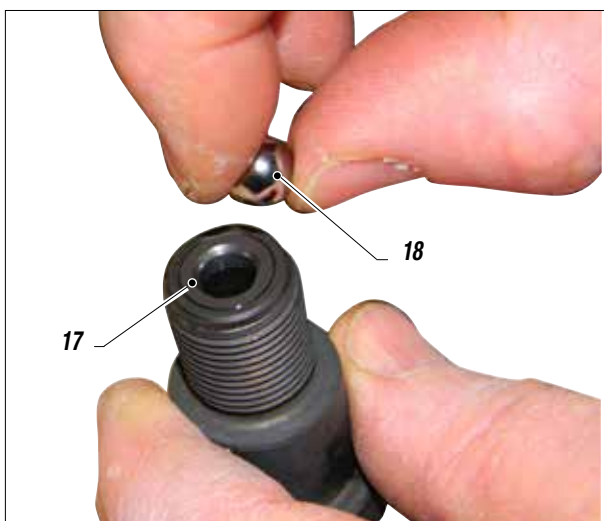

Fig. 13

- Use a screwdriver to remove the O-Ring (19) and replace it making sure it is aligned correctly (as illustrated);

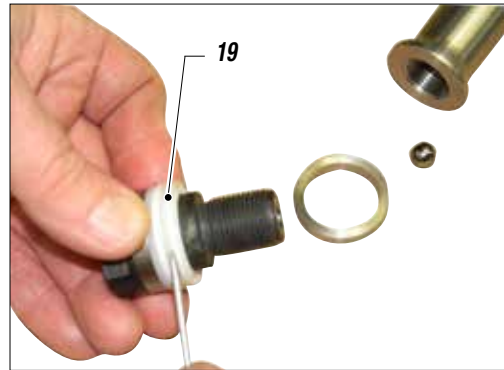

Fig. 14

- Screw the valve stem (16) (Ref. 20139) on again and tighten fully, gripping the valve in a vice. To tighten, use a 22 mm spanner; the use of a thread paste is recommended;

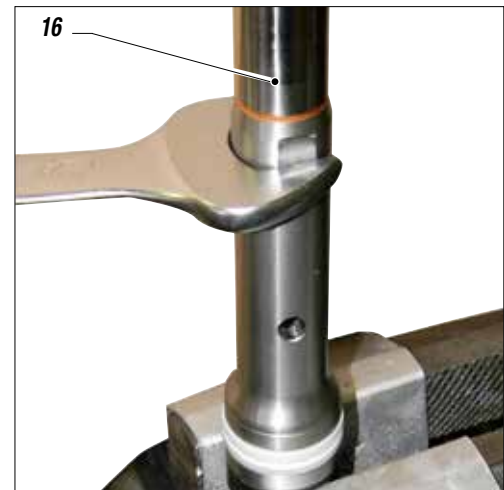

Fig. 15

Upper seal

- Remove the ring nut (20);

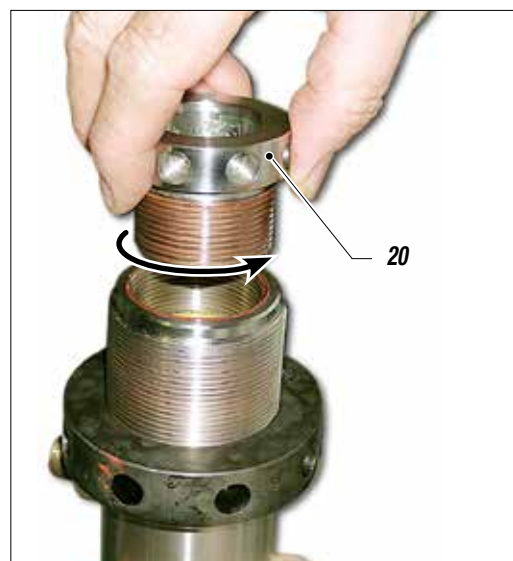

Fig. 16

- Remove the ring (21);

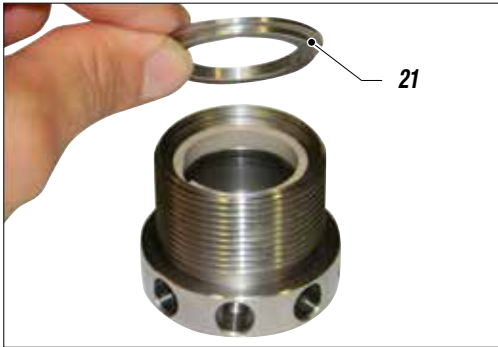

Fig. 17

- Remove the guide band (22) with a screwdriver and replace it with a new one;

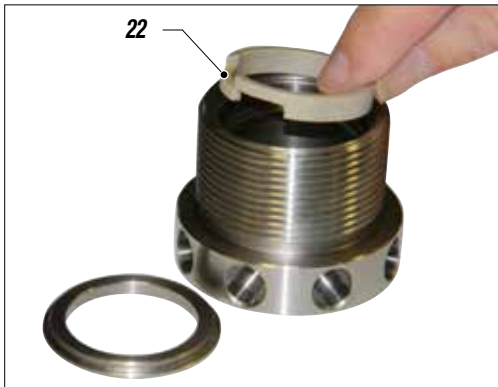

Fig. 18

- Remove the seal (23) with a screwdriver;



Fig. 19

- Using a screwdriver, remove the second band (24) located below the seal (23) and insert a new band in the same position;



Fig. 20



The positioning of the seal (23) equires special care during assembly.

- Assist insertion by applying leverage to the outside of the ring (23), pushing from the outside inwards and helping the ring to lodge in the seating, while being careful not to damage the ring's contact surfaces.



Lubricate with grease before fitting.

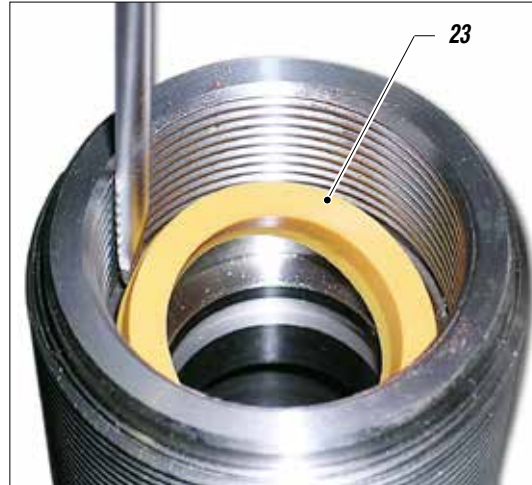

Fig. 21

- Remove the OR (25-26) from the body of the foot valve (28) and from the ball seat holder (27) and, if necessary, replace them. Reassemble the components in their proper order (as indicated in the diagram);

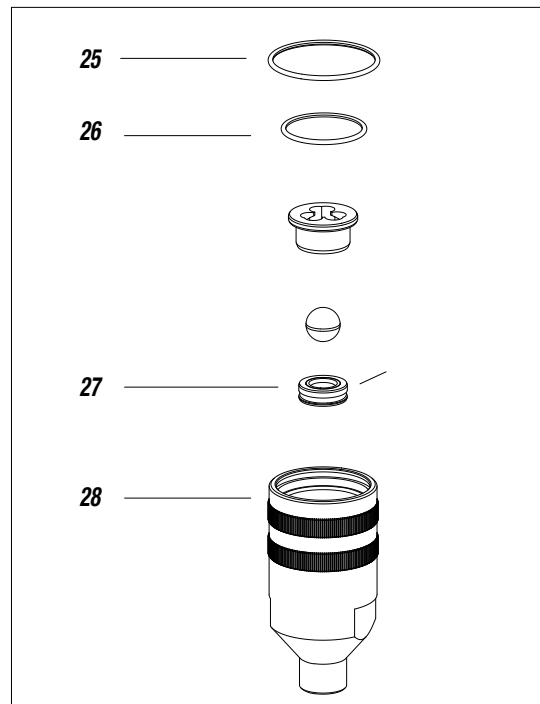

Fig. 22



To facilitate fitting the O-ring (27) it is advisable to warm it slightly with a blast of hot air.

- Check the integrity of the surface area of the sphere (17) in contact with the ball (18). If worn replace the complete detail.

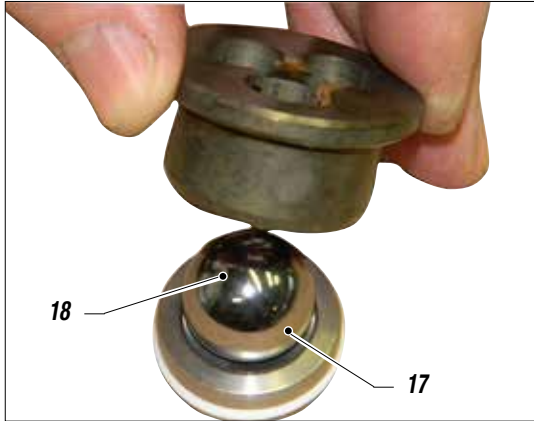

Fig. 23



The ball seating (17) is countersunk on one side, where the ball (18) must sit.

- Screw the locking ring nut (20) back onto the body of the pump unit until it makes contact, then loosen it by one turn;

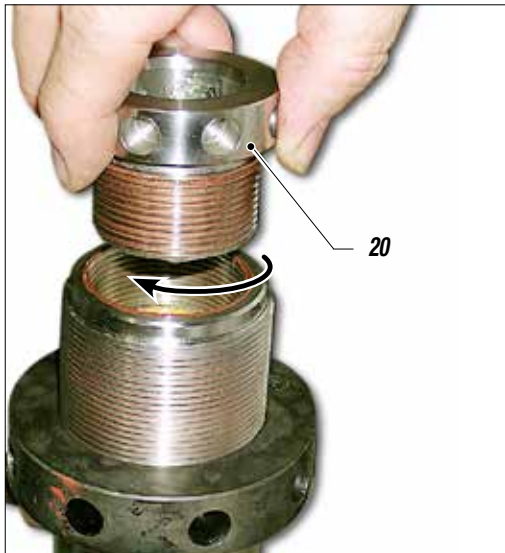

Fig. 24

- Remove the sleeve/cylinder seal (29) and replace it with a new one;

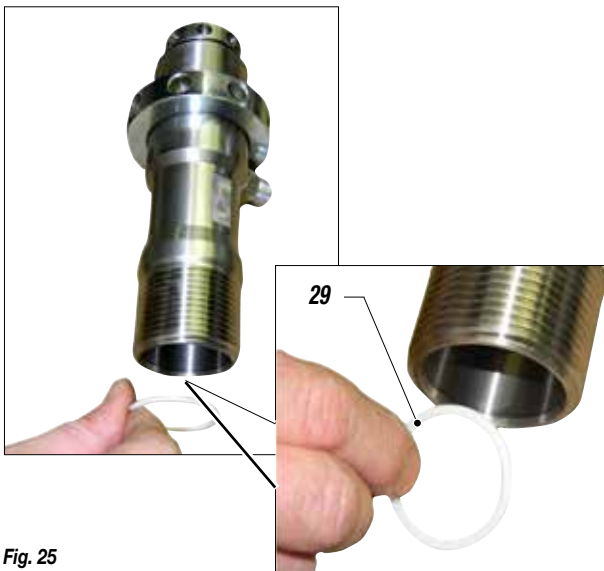

Fig. 25

- Check the wear status of the surfaces inside the jacket. Replace it if necessary;
- Grease the sleeve (30) using a paintbrush;



Fig. 26N

- Insert the sleeve (30) into the lower pump unit (31).

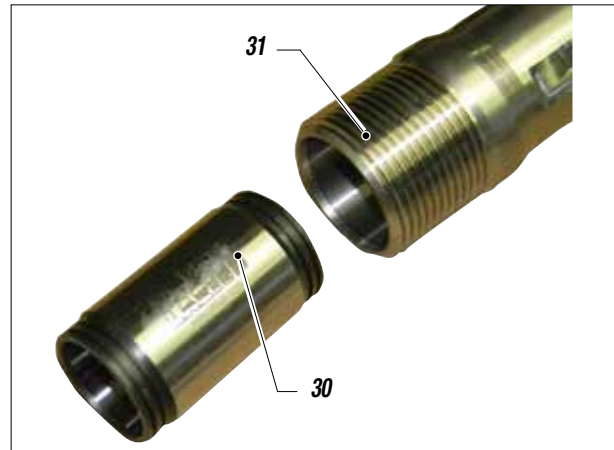

Fig. 27N



Insert the complete piston stem (32) after greasing the gaskets (33);

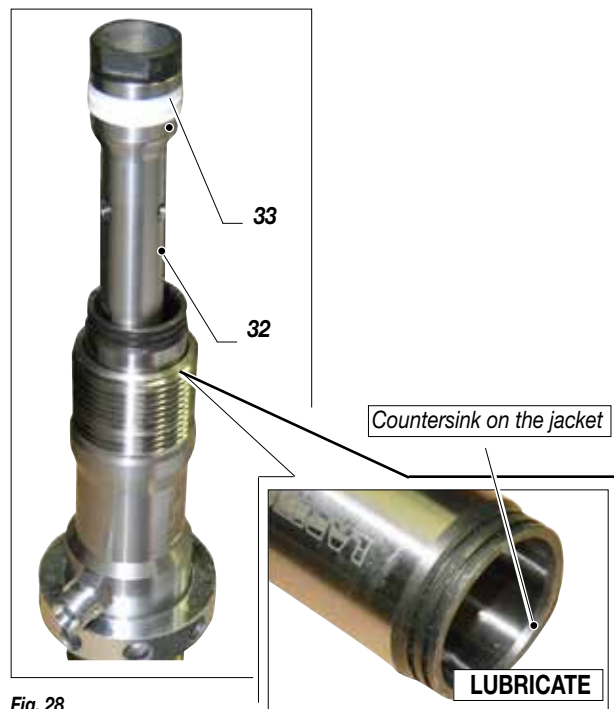

Fig. 28

- Screw on the complete foot valve (28) with the sleeve assembly (34);



In order to guarantee a proper seal, tighten the foot valve (29) fully, using a 50 mm spanner.

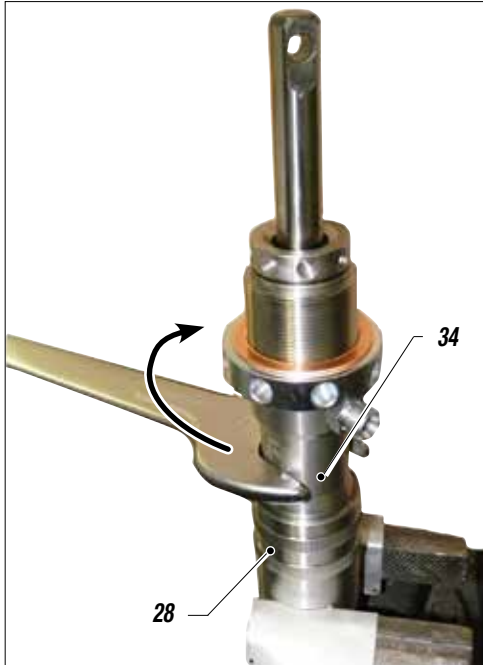

Fig. 29

- When refitting the pump unit on the machine, the stem must be at its highest point possible.
- Insert the stem into the connecting rod and insert the fixing pin (8).

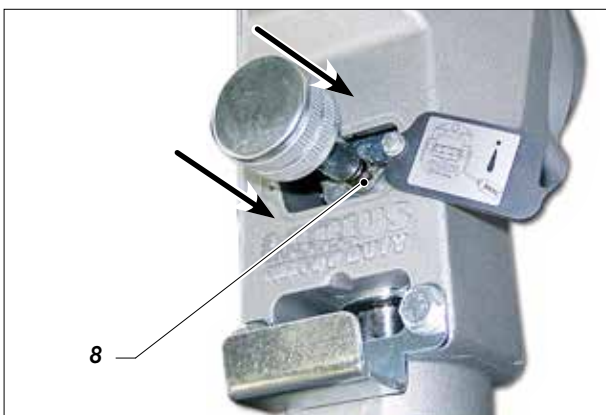

Fig. 30

- Tighten the pump casing all the way and, if the delivery pipe is not correctly aligned, unscrew the pump casing until the connection is in the correct position before tightening by using the ring nut (35) and the pin (36) supplied (Ref. 20144).

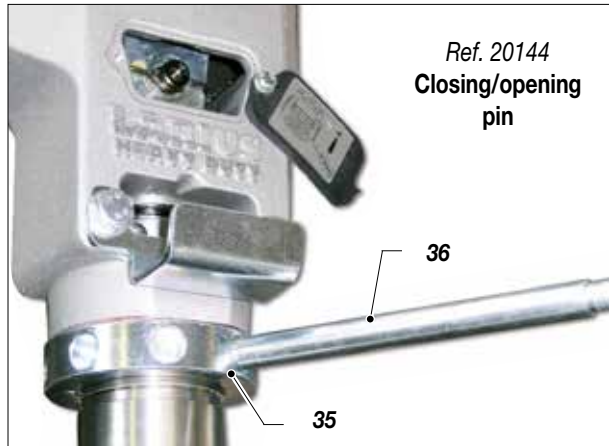

Fig. 31

- Close the seal ring nut (37) all the way.



Fig. 32

- Lubricate the upper crown (38) using oil (39) (Ref. 16340);



Fig. 33

- Refit the inspection barrier (40);

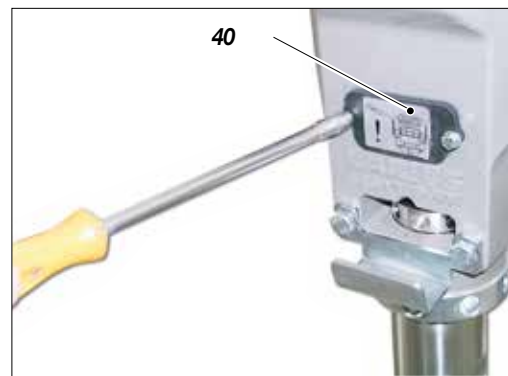
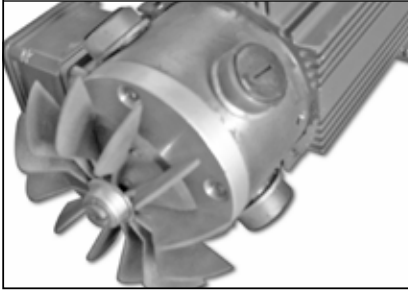

Fig. 34

- To assemble all the parts in the correct sequence, see the exploded diagram on page 32.

SPARE PARTS

T Electric motor
Page 40



O Complete electro-mechanical Unit
Page 32

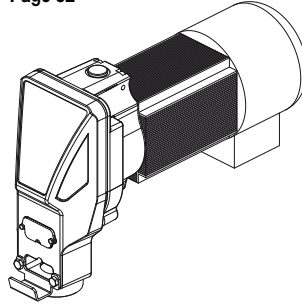

P Basic hydraulic block
ref. 35160
Page 34



R Electrical control - exploded view
Page 38



S Carriage
page 39

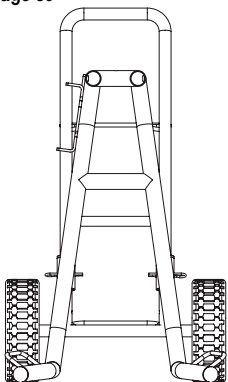

Q Complete pumping element
Page 36



0 COMPLETE ELECTRO-MECHANICAL UNIT

WARNING: Always indicate code and quantity for each part required.

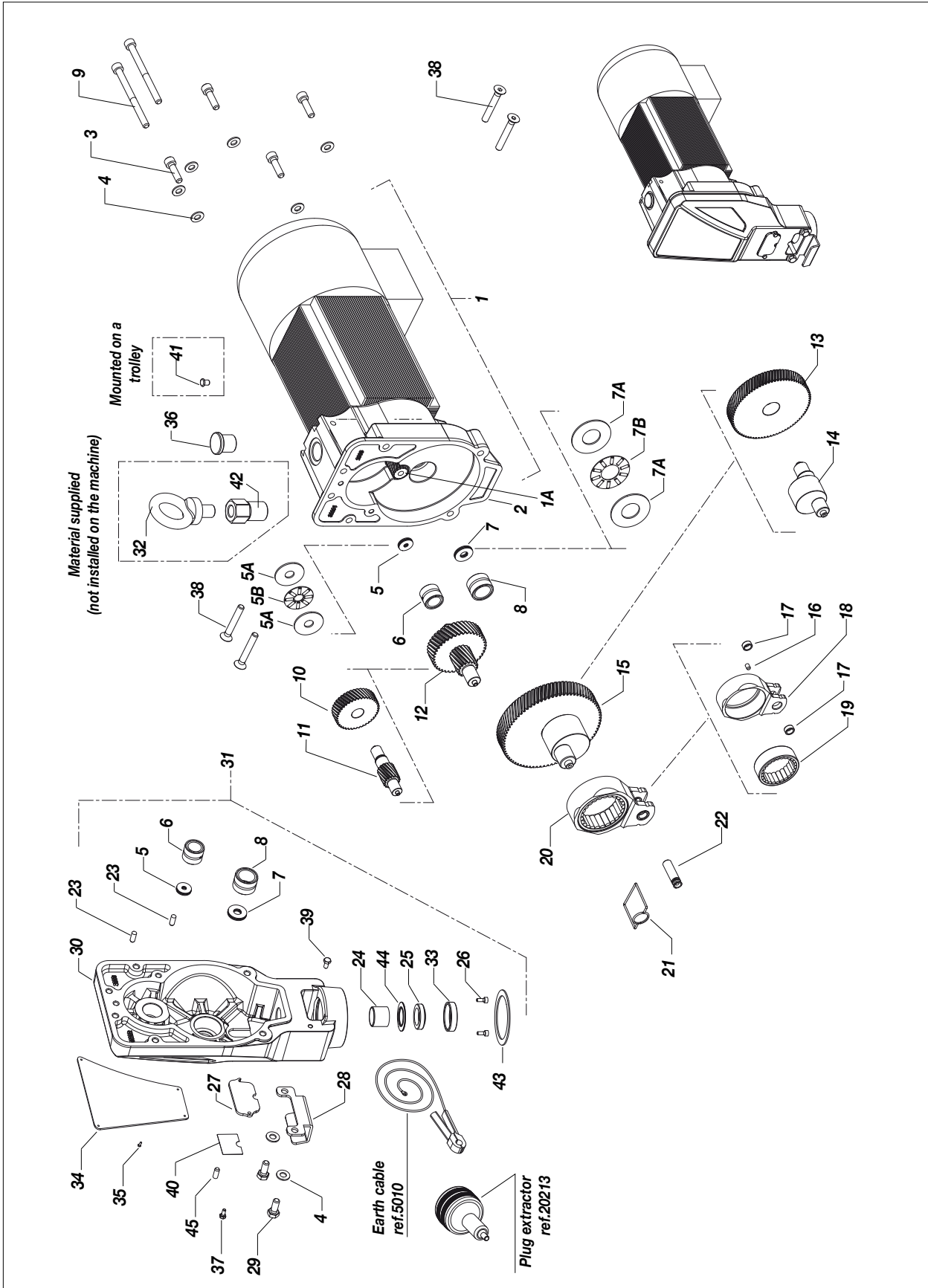

Fig. 1

Pos.	Code	Description	Q. ty
-	35144	Complete electromechanical unit model 220V 50Hz	1
.	35149	Complete electromechanical unit model 110V 60Hz	1
1	35145	Electric motor 220V 50Hz	1
	35146	Electric motor 110V 60Hz	1
1A	-	ACM Shaft motor	1
2	30201	Flange motor	1
3	30669	Screw M8X40	4
4	34009	Washer Ø 8	6
5	20250	INA Thrust bearing complete	2
5A	20251	Fifth wheel	4
5B	20252	Cage	2
6	20253	INA Roller bearing	2
7	30254	Thrust	2
7A	30255	Fifth wheel	4
7B	30256	Cage	2
8	30257	INA Roller bearing	2
9	30271	Screw M8X90	2
10	20205	Toothed wheel court	1
11	20204	Court toothed	1
12	20258	Toothed driving assembly	1
13	20207	Wheel	1
14	30206	Shaft	1
15	30259	Cam assembly	1
16	30272	Spina distanziale Ø 6X10	1
17	30208	Guide bushing	2
18	30209	Connecting rod	1
19	30261	INA Roller bearing	1
20	30262	Complete connecting rod	1

Pos.	Code	Description	Q. ty
5	35140	INA Thrust bearing complete	2
6		INA Roller bearing	2
7		Thrust	2
8		INA Roller bearing	2
24		Guide bushing	1
25		Scraper	1
26		Screw M4X10	2
30		Reduction unit cover	1
33		Fixing ring	1
34		Front sticker	1
35		Rivet Ø 2 mm	6
44		Fixing ring	1

Pos.	Code	Description	Q. ty
21	30263	Positioning spring	1
22	30210	Pump unit pivot	1
23	20264	Centring pin Ø 6X20	2
24	30665	Guide bushing	1
25	30266	Scraper	1
26	5378	Screw M4X10	2
27	30211	Inspection hatch	1
28	30212	Tin plate door	1
29	69011	Screw M8X20	2
30	30202	Reduction unit cover	1
31	35141	Cover assembly	1
32	30270	Eyebolt M16	1
33	30214	Fixing ring	1
34	35143	Front sticker	1
35	34020	Rivet Ø 2 mm	6
36	21688	Plug	1
37	20245	Screw M4X10	1
38	30245	Screw M8X60	4
39	96211	Screw M6X10	1
40	30274	Warning label	1
41	35152	Plug	1
42	18478	Threaded spacer	1
43	30666	Tightening ring	1
44	30225	Fixing ring	1
45	20278	Pin cil.	1

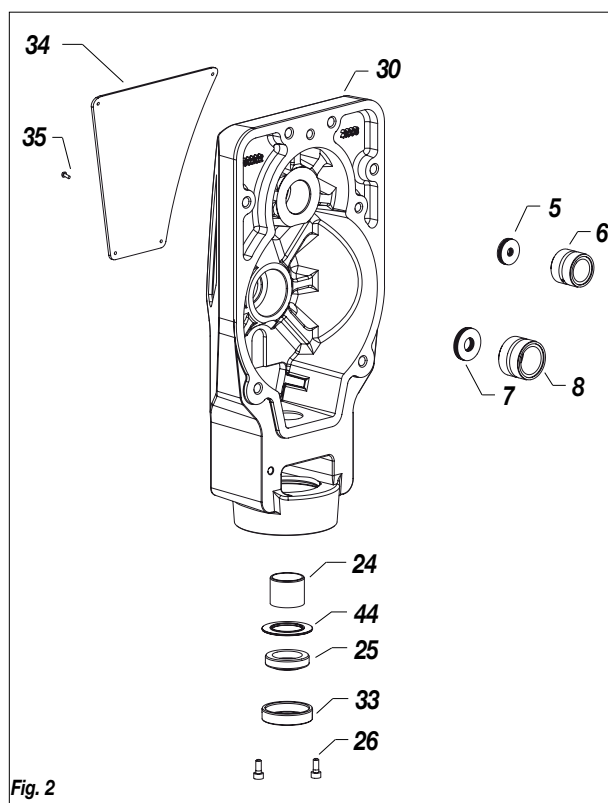

Fig. 2

P BASIC HYDRAULIC BLOCK REF. 35160

WARNING: Always indicate code and quantity for each part required.

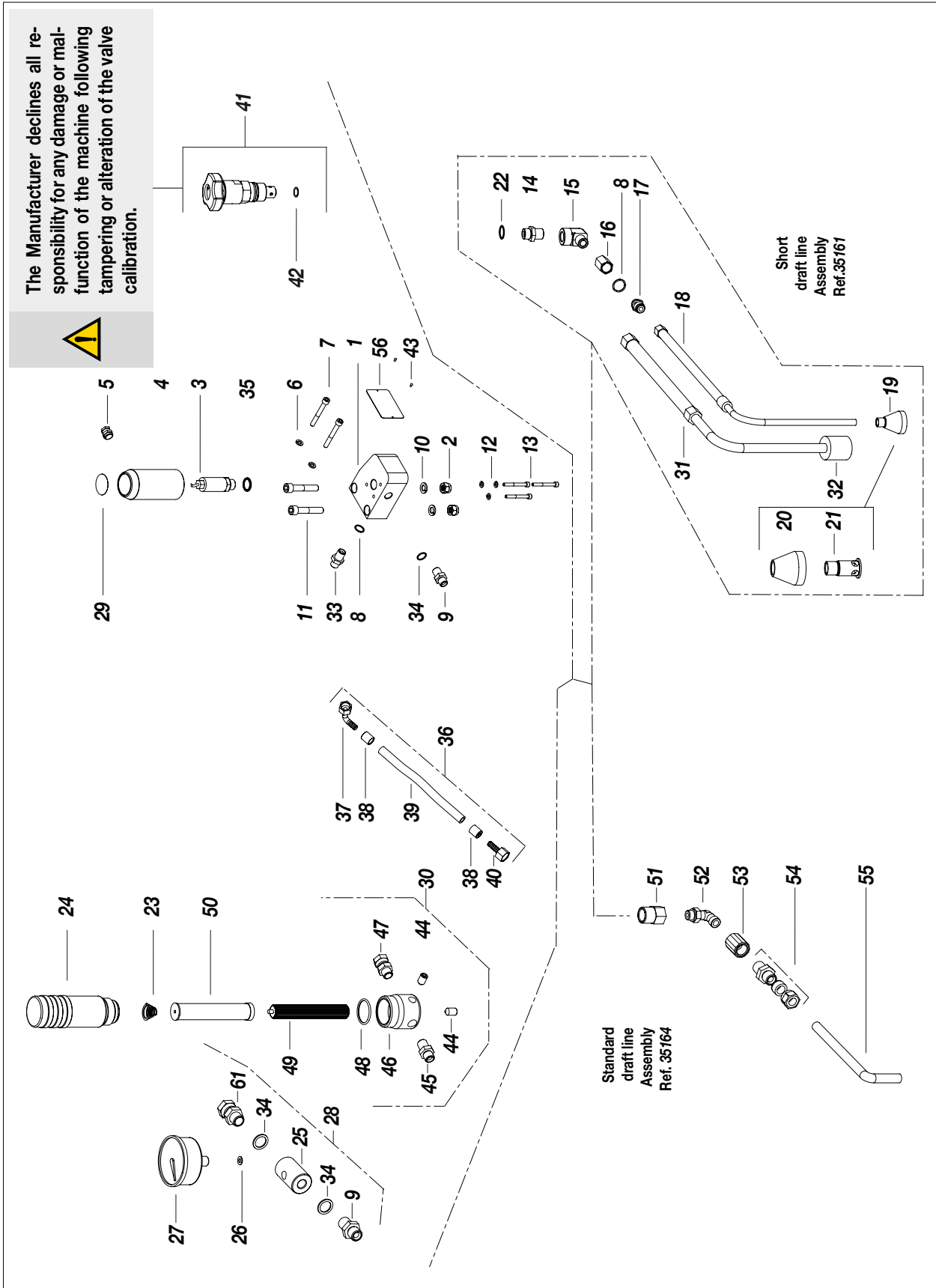

Fig. 1

Pos.	Code	Description	Q. ty
-	35160	Hydraulic block complete	-
1	30401	Block base	1
2	5756	Self-locking nut	2
3	20457	Digital pressure switch	1
4	20402	Protection	1
5	20450	Cable fastener	1
6	34009	Washer Ø 8	2
7	6151	Screw M8X50	2
8	33010	Sealing washer	1
9	33006	Nipple M16X1,5	1
10	95114	Washer Ø12	2
11	30451	Screw M12X55	2
12	32005	Washer Ø6	3
13	20436	Screw M6X60	3
14	96255	Union 0 M-M Gc 1/2"	1
15	20451	Elbow M-F Gc 1/2" - Gj 1/2"	1
16.	30430	Reduction F-F 1/2-3/8 cylindrical	1
17	3387	Nipple M-M 3/8" - M20X2	1
18	20557	Recirculation pipe compl.	1
19	18350	Bell Splash	1
20	18351	Bell	1
21	18352	Scatter pin	1
22	8071	1/2" sealing washer	1
23	96202	Sieve spring	1
24	96201	Filter tank	1
25	37452	Ball seat	1
26	37454	Gasket	1
27	53011	Manometer	1
28	147	Complete pressure gauge	1
29	30439	Warning stickers	1
30	30469	Filter assembly	1
31	20556	Induction pipe	1
32	37216	Drum filter	1
33	34109	Union M-M Gc-Gj 3/8	1
34	33007	Washer 22X16.2 SP. 15	3
35	20421	O-Ring	1

Pos.	Code	Description	Q. ty
36	20455	Discharge tube assembly	1
37	37261	Rubber holder	1
38	18511	3/8 Bushing tube	2
39	18509	Pipe compensator 3/8	1M
40	18211	Union o tuboGj 3/8	1
41	37440	Recirculation valve compl.	1
42	8402	OR 2087	1
43	11056	Ø 2,5 mm rivet	1
44	96205	Hex socket set screw	2
45	96206	Nipple M-M 1/4" - M16X1.5	1
46	96204	Base filter	1
47	37453	Union	2
48	96203	OR	1
49	96207	Sieve holder	1
50	95218	Filter sieve	1
51	5356	Reduction Gc 1/2 M -Gj 1/4 F	1
52	16131	Union Gj 1/4 M-M14X1M	1
53	35166	Standard recirculation coupling	1
54	20460	Blocking coupling	1
55	35168	Recirculation tube	1
56	35158	Label Technical Data	1

Q COMPLETE PUMP UNIT

WARNING: Always indicate code and quantity for each part required.

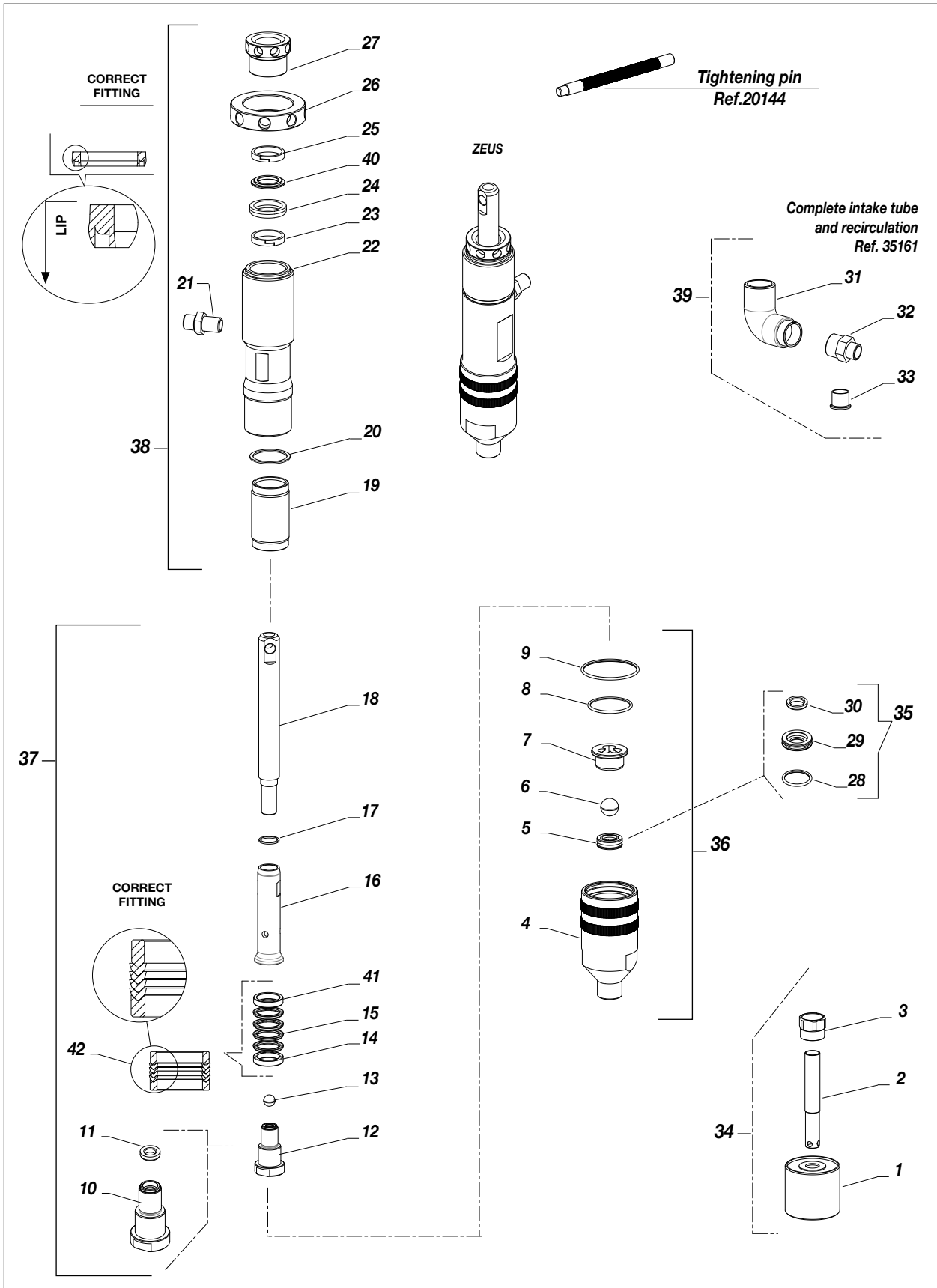

Fig. 1

Pos.	Code	Description	Q. ty	Pos.	Code	Description	Q. ty
-	35100	Zeus standard 220 V	-	17	37180	O-Ring	1
-	35102	Zeus short 220 V	-	18	35131	Upper stem	1
-	35150	Zeus standard 110 V	-	19	35133	Sleeve	1
-	35155	Zeus short 110 V	-	20	35134	Seal	1
-	35110	Complete standard pump unit	-	21	95230/1	Adapter 3/8 AP M-M	1
-	35111	Complete pumping with suction hose	-	22	35135	Pump unit casing	1
-	35112	Foot valve seal kit	-	23	30142	67806-X0220-56Z	1
-	35113	Complete seal kit	-	24	30139	EAR 148856-02	1
-	35114	Jacket+piston kit	-	25	30138	67806-X0220-A22Z	1
-	35161	Suction hose kit + recirculation	-	26	30114	Tightening ring nut	1
1	37216	Suction filter	1	27	30113	Stuffing nut	1
2	35118	Hard suction hose	1	28	35162	OR 3087	1
3	37229	Connection	1	29	35119	Accommodation ball seat	1
4	35115	Foot valve	1	30	96836/2	See ball	1
5	35116	Assembled at Ball	1	31	98374	Elbow joint F-F Gj 3 / 4	1
6	35163	Ball Ø 3/4"	1	32	98376	Suction fitting Jas M-M 3 / 4 - M36x2	1
7	35138	Ball guide	1	33	96099	Seal sleeve	1
8	35121	OR 3156	1	34	35139	Assembly float rigid	
9	35122	OR 3206	1	35	35117	Assembly the valve seat F	
10	35124	Valve stem	1	36	35123	Assembly the group see fund	
11	7062	See ball	1	37	35132	Assembly the stem	
12	35125	Valve stem comp.	1	38	35136	Assembly cylinder	
13	7071	Ball Ø 9	1	39	35137	Suction hose Assembly kit	
14	35151	Ring female lower	1	40	30122	Ring seal top awards	1
15	35154	Polyethylene gasket	2	41	35142	Ring male lower	1
	35157	PTFE gasket	2	42	35159	Pack lower packing	1
16	35129	Lower stem	1				

R ELECTRICAL CONTROL - EXPLODED VIEW

WARNING: Always indicate code and quantity for each part required.

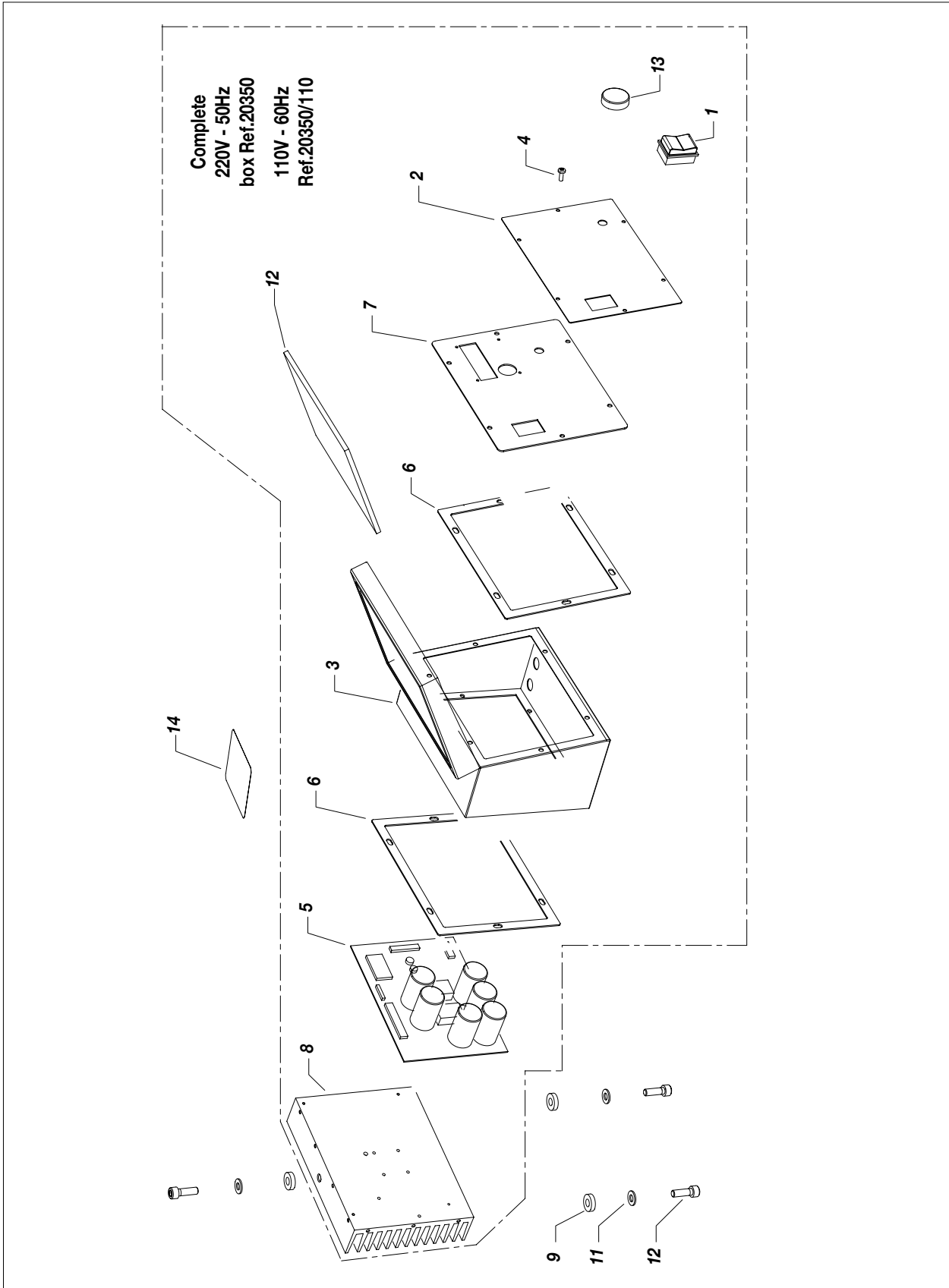

Fig. 1

Pos.	Code	Description	Q. ty
		Electronic box A.C.	
-	30350	- Model 220V - 50Hz	-
-	30357	- Model 110V - 60Hz	-
1	5933	Switch	1
2	20355	Panel	1
3	20354	Electronic box	1
4	96028	Screw	6
5	20365	Electronic board	1
6	18483	Short rubber seal	2

Pos.	Code	Description	Q. ty
7	18493	Tightening plate	1
8	20352	Dissipator	1
9	8011	Anti-vibration washers	3
10	34009	Washer	3
11	34008	Screw	3
12	20340	Transparent sheet	1
13	20349	Knob	1
14	30280	Technical data label	1

S CARRIAGE

WARNING: Always indicate code and quantity for each part required.

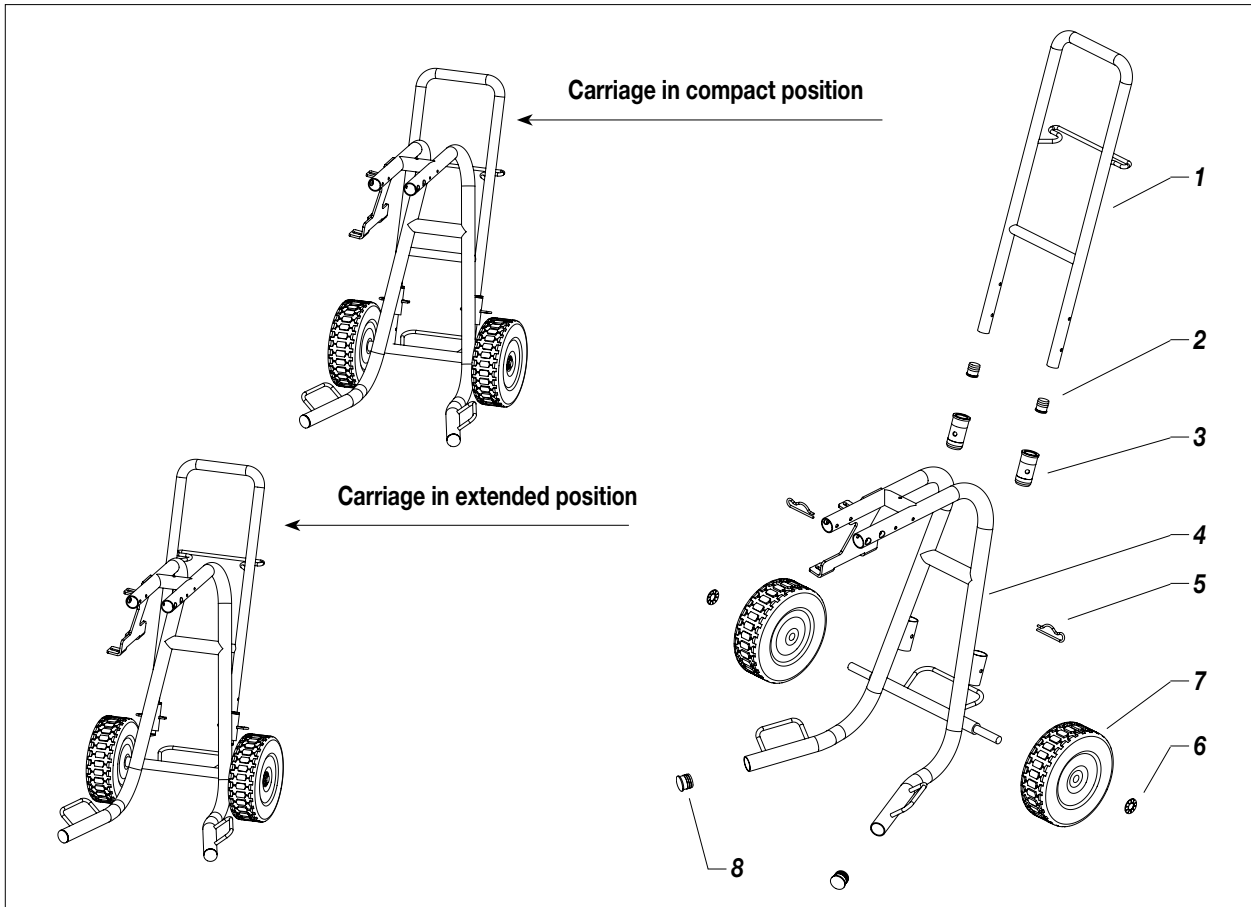

Fig. 1

Pos.	Code	Description	Q. ty
-	30300	Complete carriage	-
1	30301	Carrying handle	1
2	95159	Pipe cap	2
3	18914	Bushing	2
4	30302	Carriage	1

Pos.	Code	Description	Q. ty
5	18902	Split pin	2
6	20305	Wheel stop washer	2
7	37238	Wheel Ø260 mm	2
8	30304	Pipe cap	2

T ELECTRIC MOTOR

WARNING: Always indicate code and quantity for each part required.

- Periodically check on the wear of the pinion (*at least every 1000 working hours*).
- Periodically check the perfect connection among all the electrical components (*at least every 200 working hours*).
- The length of the brush contact must be higher than 9 mm to guarantee a good working of the rotary group.



DISCONNECT THE POWER SUPPLY BEFORE CHECKING OR REPLACING THE BRUSHES.

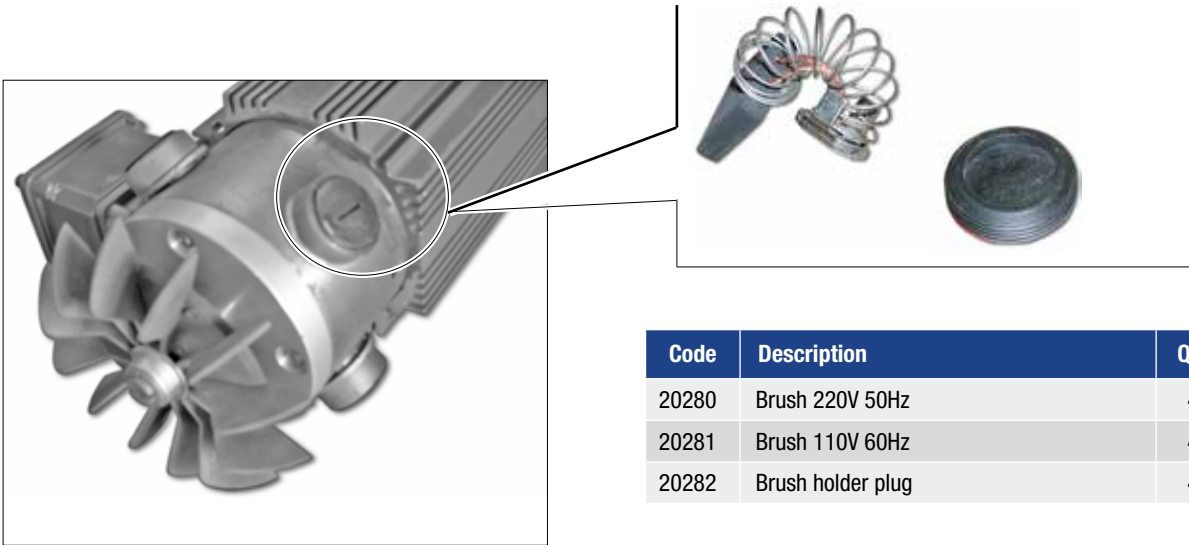

Code	Description	Q. ty
20280	Brush 220V 50Hz	4
20281	Brush 110V 60Hz	4
20282	Brush holder plug	4

Fig. 1

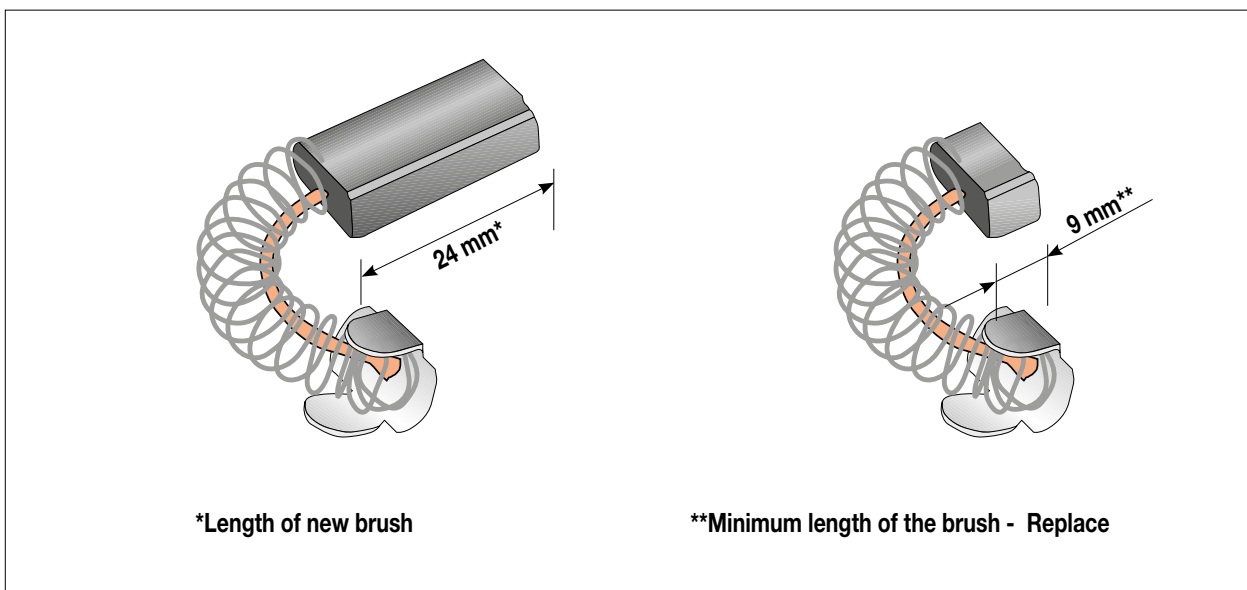

*Length of new brush

**Minimum length of the brush - Replace

Fig. 2

ELECTRICAL DIAGRAM

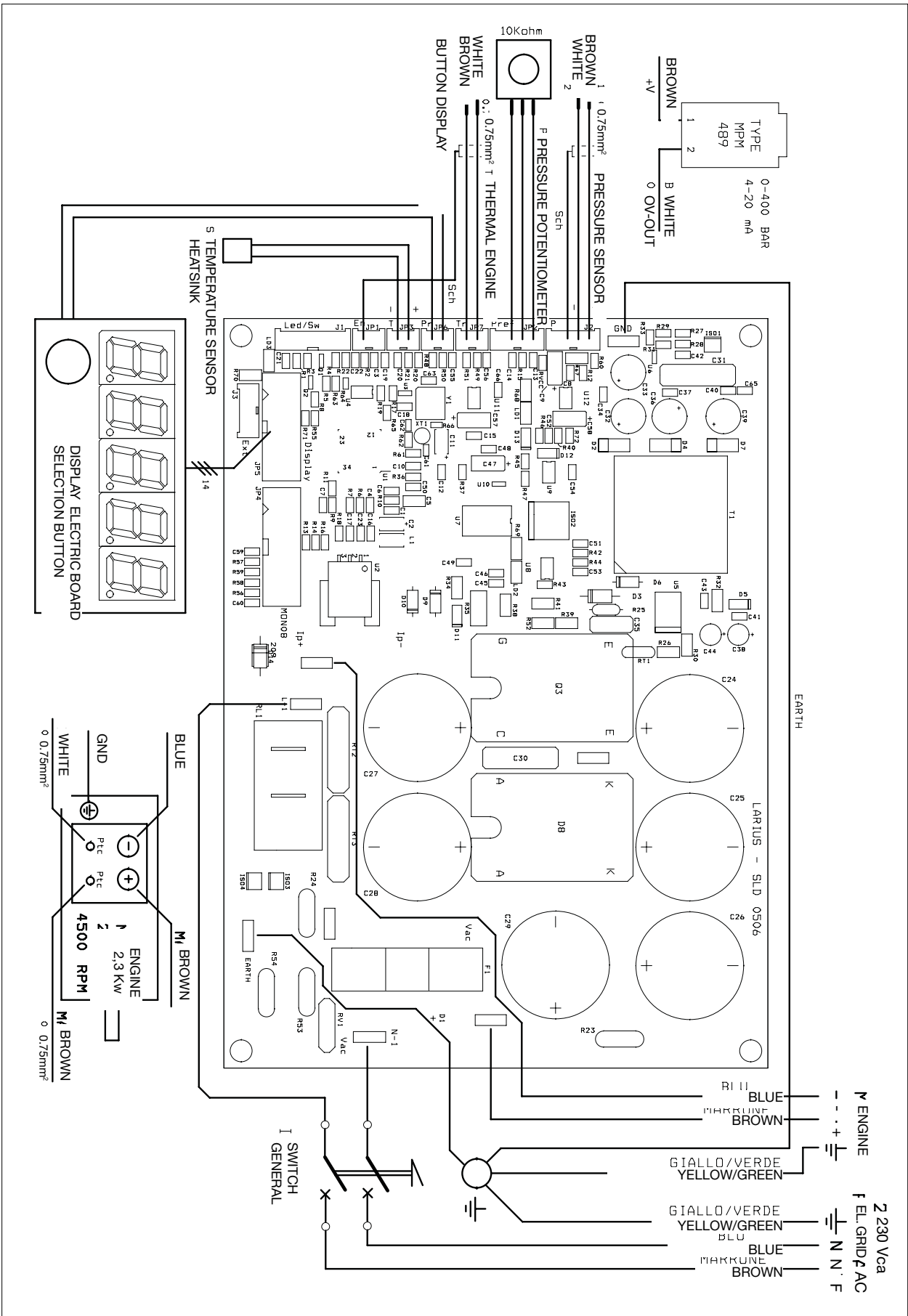

Fig. 1

Intentionally blank page



CE DECLARATION OF CONFORMITY



Company



LARIUS srl
Via Antonio Stoppani 21 - 23801 Calolziocorte (LC) ITALY
Tel: +39 0341 621152
Fax: +39 0341 621243
E-mail: larius@larius.com

Declares under his owns responsibility that the product:

ZEUS Electric piston pump

complies with the directives:

- EC Directive 2006/42 Machinery Directive
- EU Directive 2014/30 Electromagnetic Compatibility (EMC)
- EU Directive 2014/35 Low Voltage (LVD)

furthermore to the
harmonized standards:

- UNI EN ISO 12100-1/-2
Machinery safety, basic concepts, general principles of design. Basic terminology, methodology. Technical principles.

This declaration relates exclusively to the product in the state in which it was placed on the market, and excludes components or modifications which are added or carried out subsequently by end user.

Signature

Pierangelo Castagna
Managing Director

Calolziocorte, 31 May 2024
Location / Date



**SAMOA INDUSTRIAL, S.A. - HEADQUARTERS
SPAIN AND EXPORT MARKETS**

POL. IND. PORCEYO, I-14 - CAMINO DEL FONTÁN, 831
E-33392 GIJÓN (ASTURIAS), SPAIN
TEL.: +34 985 381 488 - FAX: + 34 985 147 213

**SAMOA S.A.R.L.
FRANCE**

P.A.E.I. DU GIESSEN
3, RUE DE BRISCHBACH
67750 SCHERWILLER, FRANCE
TEL.: +33 3 88 82 79 62 - FAX: +33 3 88 82 77 88

**SAMOA ITALIA - LARIUS
ITALY**

VIA ANTONIO STOPPANI,21
23801 CALOLZIOCORTE (LC) ITALY
Tel.: +39 0341 621152 - Fax: + 39 0341 621242

SAMOA FLOWTECH GMBH

GERMANY, AUSTRIA, SWITZERLAND, THE NETHERLANDS AND GREECE
AM OBEREICHHOLZ 4
D - 97828 MARKTHEIDENFELD, GERMANY
TEL.: +49 9391 9826 0 - FAX: +49 9391 98 26 50

SAMOA LTD.

UNITED KINGDOM AND REP. OF IRELAND

ASTURIAS HOUSE - BARRS FOLD ROAD
WINGATES INDUSTRIAL PARK
WESTHOUGHTON, BL5 3XP, UK
TEL.: +44 1942 850600 - FAX: +44 1942 812160

SAMOA CORPORATION

USA AND CANADA
90 MONTICELLO ROAD
WEAVERVILLE, NC 28787, USA
TEL. +1 (828) 645-2290 - FAX: +1 (828) 658 0840



©Copyright, SAMOA INDUSTRIAL, S.A.
SAMOA Industrial, S.A. is an ISO 9001, ISO 14001 and ISO 45001 certified company.

»»» Contact us today!
Visit www.samoaindustrial.com for more information.

OPERATING AND MAINTENAINCE MANUAL AVAILABLE IN:		
	IT	https://www.larius.com/wp-content/uploads/ZEUS_I.pdf
	EN	https://www.larius.com/wp-content/uploads/ZEUS_GB.pdf
	DE	https://www.larius.com/wp-content/uploads/ZEUS_D.pdf
	FR	https://www.larius.com/wp-content/uploads/ZEUS_F.pdf
	ES	https://www.larius.com/wp-content/uploads/ZEUS_ES.pdf
	PL	https://www.larius.com/wp-content/uploads/ZEUS_PL.pdf