



www.larius.com

THOR

Electric piston pump



IT	https://www.larius.com/wp-content/uploads/THOR_I.pdf
EN	https://www.larius.com/wp-content/uploads/THOR_GB.pdf
DE	https://www.larius.com/wp-content/uploads/THOR_D.pdf
FR	https://www.larius.com/wp-content/uploads/THOR_F.pdf
ES	https://www.larius.com/wp-content/uploads/THOR_E.pdf
PL	https://www.larius.com/wp-content/uploads/THOR_PL.pdf
PT	https://www.larius.com/wp-content/uploads/THOR_P.pdf

20704	THOR electric motor pump
K20704	THOR electric motor pump + gun
20703	THOR petrol motor pump
K20703	THOR petrol motor pump + gun



This manual is to be considered as an English language translation of the original manual in Italian. The manufacturer shall bear no responsibility for any damages or inconveniences that may arise due to the incorrect translation of the instructions contained within the original manual in Italian.

Due to a constant product improvement programme, the factory reserves the right to modify technical details mentioned in this manual without prior notice.

THOR

Electric piston pump

INDEX



















A WARNINGS.....	4	Q.1 COMPLETE REPAIR KIT AND SLEEVE KIT PLUS PISTON FOR ..	
B TRANSPORT AND UNPACKING	5	LONG PUMPING UNIT	42
C CONDITIONS OF GUARANTEE.....	5	Q.2 GASKET KIT FOR LONG PUMPING UNIT.....	44
D SAFETY RULES.....	5	R SHORT PUMPING UNIT FOR STANDARD PRODUCTS.....	46
E WORKING PRINCIPLE.....	7	S SPARE KIT FOR SHORT PUMPING UNIT	48
F TECHNICAL DATA	8	S.1 COMPLETE REPAIR KIT AND SLEEVE KIT PLUS PISTON FOR ..	
G DESCRIPTION OF THE EQUIPMENT.....	9	SHORT PUMPING UNIT.....	48
H SETTING-UP	12	S.2 GASKET KIT FOR SHORT PUMPING UNIT	50
I WORKING.....	16	T FILTER ASSEMBLY COD. 37410.....	51
J CLEANING AT THE END OF THE WORK	19	U PRESSURE CONTROL DEVICE	52
K ROUTINE MAINTENANCE	24	V SUCTION AND CIRCULATION UNIT FOR STANDARD PRODUCTS..	54
L PROBLEMS AND SOLUTIONS.....	27	W TROLLEY	55
M CORRECT PROCEDURE OF DECOMPRESSION	28	X TANK.....	56
N REPLACEMENT OF THE PUMPING GROUP'S GASKETS.....	29	Y ELECTRICAL CONTROL	58
SPARE PARTS		Z ELECTRIC MOTOR	59
O COMPLETE ELECTRO-MECHANICAL UNIT	38	AA ELECTRICAL DIAGRAM	60
P COMPLETE LONG PUMPING UNIT	40	DECLARATION OF CONFORMITY	61
Q SPARE KIT FOR LONG PUMPING UNIT	42		

**WE ADVISE THE USE OF THIS EQUIPMENT ONLY BY PROFESSIONAL OPERATORS.
 ONLY USE THIS MACHINE FOR USAGE SPECIFICALLY MENTIONED IN THIS MANUAL.**

Thank you for choosing a **SAMOA** product.
 As well as the product purchased, you will receive a range of support services
 enabling you to achieve the results desired, quickly and professionally.

A WARNINGS

The table below provides the meaning of the symbols used in this manual in relation to using, earthing, operating, maintaining, and repairing of this equipment.

	<ul style="list-style-type: none"> • Read this operator's manual carefully before using the equipment. • An improper use of this machine can cause injuries to people or things. • Do not use this machine when under the influence of drugs or alcohol. • Do not modify the equipment under any circumstances. • Use products and solvents that are compatible with the various parts of the equipment, and read the manufacturer's warnings carefully. • See the Technical Details for the equipment given in the Manual. • Check the equipment for worn parts once a day. If any worn parts are found, replace them using ONLY original spare parts. • Keep children and animals away from work area. • Comply with all safety standards.
	<ul style="list-style-type: none"> • It indicates an accident risk or serious damage to equipment if this warning is not followed.
   	<p>FIRE AND EXPLOSION HAZARD</p> <ul style="list-style-type: none"> • Solvent and paint fumes in work area can ignite or explode. • To help prevent fire and explosion: <ul style="list-style-type: none"> - Use equipment ONLY in well ventilated area. - Eliminate all ignition sources, such as pilot lights, cigarettes and plastic drop cloths (potential static arc). - Ground equipment and conductive objects. - Use only grounded hoses. - Do not use trichloroethane, methylene chloride, other halogenated hydrocarbon solvents or fluids containing such solvents in pressurized aluminium equipment. Such use can cause serious chemical reaction and equipment rupture, and result in death, serious injury, and property damage. - Do not form connections or switch light switches on or off if the air contains inflammable fumes. • If electrical shocks or discharges are encountered the operation being carried out using the equipment must be stopped immediately. • Keep a fire extinguisher at hand in the immediate vicinity of the work area.
	<ul style="list-style-type: none"> • It indicates wound and finger squashing risk due to movable parts in the equipment. • Tenersi lontano dalle parti in movimento. • Do not use the equipment without the proper protection. • Before any inspection or maintenance of the equipment, carry out the decompression procedure explained in this manual, and prevent any risk of the equipment starting unexpectedly.
 	<ul style="list-style-type: none"> • Report any risk of chemical reaction or explosion if this warning has not been given. • (IF PROVIDED) There is a risk of injury or serious lesion related to contact with the jet from the spray gun. If this should occur, IMMEDIATELY contact a doctor, indicating the type of product injected. • (IF PROVIDED) Do not spray before the guard has been placed over the nozzle and the trigger on the spray gun. • (IF PROVIDED) Do not put your fingers in the spray gun nozzle. • Once work has been completed, before carrying out any maintenance, complete the decompression procedure.
	<ul style="list-style-type: none"> • It indicates important recommendations about disposal and recycling process of products in accordance with the environmental regulations.
    	<ul style="list-style-type: none"> • Mark any clamps attached to earth cables. • Use ONLY 3-wire extension cords and grounded electrical outlets. • Before starting work make sure that the electrical system is grounded and that it complies with safety standards. • High-pressure fluid from gun, hose leaks, or ruptured components will pierce skin. • To help prevent injection, always: <ul style="list-style-type: none"> - (IF PROVIDED) Engage trigger lock when not spraying. - (IF PROVIDED) Do not put your hand over the spray tip. Do not stop or deflect leaks with your hand, body or other. - (IF PROVIDED) Do not point gun at anyone or at any part of the body. - (IF PROVIDED) Never spray without tip guard. - Do pressure relief if you stop spraying or being servicing sprayer and before any maintenance operations. - Do not use components rated less than sprayer Maximum Working Pressure. - Never allow children to use this unit - (IF PROVIDED) Brace yourself; gun may recoil when triggered. • If high pressure fluid pierces your skin, the injury might look like "just a cut", but it is a serious wound! Get immediate medical attention.
   	<ul style="list-style-type: none"> • It is obligatory to wear suitable clothing as gloves, goggles and face shield. • Wear clothing that complies with the safety standards in force in the country in which the equipment is used. • Do not wear bracelets, earrings, rings, chains, or anything else that may hinder the operator's work. • Do not wear clothing with wide sleeves, scarves, ties, or any other piece of clothing that could get tangled up in moving parts of the equipment during the work, inspection, or maintenance cycles.

B TRANSPORT AND UNPACKING

- The packed parts should be handled as indicated in the symbols and markings on the outside of the packing.
- Before installing the equipment, ensure that the area to be used is large enough for such purposes, is properly lit and has a clean, smooth floor surface.
- The manufacturer will not be responsible for the unloading operations and transport to the workplace of the machine.
- Check the packing is undamaged on receipt of the equipment. Unpack the machine and verify if there has been any damage due to transportation.

In case of damage, call immediately the manufacturer and the Shipping Agent. All the notices about possible damage or anomalies must arrive timely within 8 days at least from the date of receipt of the plant through Registered Letter to the Shipping Agent and to the manufacturer.

- The user is responsible for the operations of unloading and handling and should use the maximum care so as not to damage the individual parts or injure anyone. To perform the unloading operation, use only qualified and trained personnel (truck and crane operators, etc.) and also suitable hoisting equipment for the weight of the installation or its parts.

Follow carefully all the safety rules.

The personnel must be equipped with the necessary safety clothing.



The disposal of packaging materials is a customer's competence and must be performed in accordance with the regulations in force in the country where the plant is installed and used. It is nevertheless sound practice to recycle packaging materials in an environment-friendly manner as much as possible.

C CONDITIONS OF GUARANTEE



The conditions of guarantee do not apply in the following situations:

- improper washing and cleaning of components causing malfunction, wear or damage to the equipment or any of its parts;
- improper use of the equipment;
- use that does not conform with applicable national legislation;
- incorrect or faulty installation;
- modifications, interventions and maintenance that have not been authorised by the manufacturer;
- use of non-original spare parts or parts that do not correspond to the specific model;
- total or partial non-compliance with the instructions provided.

D SAFETY RULES

- THE EMPLOYER SHALL TRAIN ITS EMPLOYEES ABOUT ALL THOSE RISKS STEMMING FROM ACCIDENTS, ABOUT THE USE OF SAFETY DEVICES FOR THEIR OWN SAFETY AND ABOUT THE GENERAL RULES FOR ACCIDENT PREVENTION IN COMPLIANCE WITH INTERNATIONAL REGULATIONS AND WITH THE LAWS OF THE COUNTRY WHERE THE PLANT IS USED.
- THE BEHAVIOUR OF THE EMPLOYEES SHALL STRICTLY COMPLY WITH THE ACCIDENT PREVENTION AND ALSO ENVIRONMENTAL REGULATIONS IN FORCE IN THE COUNTRY WHERE THE PLANT IS INSTALLED AND USED.



Read carefully and entirely the following instructions before using the product. Please save these instructions in a safe place.

The unauthorised tampering/replacement of one or more parts composing the machine, the use of accessories, tools, expendable materials other than those recommended by the manufacturer can be a danger of accident.

The manufacturer will be relieved from tort and criminal liability.

- KEEP YOUR WORK PLACE CLEAN AND TIDY. DISORDER WHERE YOU ARE WORKING CREATES A POTENTIAL RISK OF ACCIDENTS.
- ALWAYS KEEP PROPER BALANCE AVOIDING UNUSUAL STANCE.
- BEFORE USING THE TOOL, ENSURE THERE ARE NOT DAMAGED PARTS AND THE MACHINE CAN WORK PROPERLY.
- ALWAYS FOLLOW THE INSTRUCTIONS ABOUT SAFETY AND THE REGULATIONS IN FORCE.
- KEEP THOSE WHO ARE NOT RESPONSIBLE FOR THE EQUIPMENT OUT OF THE WORK AREA.
- **NEVER** EXCEED THE MAXIMUM WORKING PRESSURE INDICATED.
- **NEVER** POINT THE SPRAY GUN AT YOURSELVES OR AT OTHER PEOPLE. THE CONTACT WITH THE CASTING CAN CAUSE SERIOUS INJURIES. IN CASE OF INJURIES CAUSED BY THE GUN CASTING, SEEK IMMEDIATE MEDICAL ADVICE SPECIFYING THE TYPE OF THE PRODUCT INJECTED. **NEVER** UNDERVALUE A WOUND CAUSED BY THE INJECTION OF A FLUID.
- ALWAYS DISCONNECT THE SUPPLY AND RELEASE THE PRESSURE IN THE CIRCUIT BEFORE PERFORMING ANY CHECK OR PART REPLACEMENT OF THE EQUIPMENT.
- NEVER MODIFY ANY PART IN THE EQUIPMENT. CHECK REGULARLY THE COMPONENTS OF THE SYSTEM. REPLACE THE PARTS DAMAGED OR WORN.
- TIGHTEN AND CHECK ALL THE FITTINGS FOR CONNECTION BETWEEN PUMP, FLEXIBLE HOSE AND

SPRAY GUN BEFORE USING THE EQUIPMENT.

- ALWAYS USE THE FLEXIBLE HOSE SUPPLIED WITH STANDARD KIT. THE USE OF ANY ACCESSORIES OR TOOLING OTHER THAN THOSE RECOMMENDED IN THIS MANUAL, MAY CAUSE DAMAGE OR INJURE THE OPERATOR.
- THE FLUID CONTAINED IN THE FLEXIBLE HOSE CAN BE VERY DANGEROUS. HANDLE THE FLEXIBLE HOSE CAREFULLY. DO NOT PULL THE FLEXIBLE HOSE TO MOVE THE EQUIPMENT. NEVER USE A DAMAGED OR A REPAIRED FLEXIBLE HOSE.
- NEVER SPRAY OVER FLAMMABLE PRODUCTS OR SOLVENTS IN CLOSED PLACES.
- NEVER USE THE TOOLING IN PRESENCE OF POTENTIALLY EXPLOSIVE GAS.



The high speed of travel of the product in the hose can create static electricity through discharges and sparks.



It is suggested to earth the equipment.

The gun is earthed through the high pressure flexible hose.



All the conductors near the work area must be earthed.



Always check the product is compatible with the materials composing the equipment (*pump, spray gun, flexible hose and accessories*) with which it can come into contact.



Never use paints or solvents containing halogen hydrocarbons (as the methylene chloride).

If these products come into contact with aluminium parts can provoke dangerous chemical reactions with risk of corrosion and explosion.



If the product to be used is toxic, avoid inhalation and contact by using protection gloves, goggles and proper face shields.



Take proper safety measures for the protection of hearing in case of work near the plant.

Electrical safety precautions

- Check the switch is on the “OFF” position before connecting the cable to the mains.
- Never carry a plugged-in equipment.
- Disconnect the equipment before storing it and before performing any maintenance operation or replacing of accessories.
- Do not carry the equipment neither unplug it by pulling the electric cable.
- Protect the cable from heat, oil and sharp edges.
- When the tool is used outdoors, use only an extension cable suited for outdoor use and so marked.



Never attempt to tamper with the calibre of instruments.

- Take care when the pumping rod is moving. Stop the machine whenever someone is within its vicinity.
- Repairs of the electrical equipment should only be carried out by skilled personnel, otherwise considerable danger to the user may result.

E WORKING PRINCIPLE

The **THOR** unit is defined “electric piston pump”.

An electric piston pump is used for high pressure painting without air (from this process derives the term “airless”).

The pump is controlled by an electric motor coupled with a reduction gear.

A cam shaft and a connecting rod allow to obtain the reciprocating motion necessary to the working of the “pumping group” piston. The piston movement produces a “vacuum”.

The product is sucked, pushed towards the pump outlet and then sent to the gun through the flexible hose.

An electronic device located next to the reduction box, is used to regulate and control the pressure of the material leaving the

pump. When the pump reaches the set value, the motor stops and starts again when the value decreases.

A safety valve avoiding overpressure, guarantees the total reliability of the equipment.



Fig. 1

Fields of application	Application materials	
Indoor	Top-coat plaster	Intumescent
Outdoor	Self-levelling plasters	Encapsulators
Industrial buildings	Fillers	Insulation
Industrial constructions	Stuccos	Water proofing
Redeveloping	Plasters	Elastomers
Roofing	Pre-mixed plasters (granulometry 0,0)	Epoxi resins Bitumen

COD.	MOTOR	HOSE	GUN
20704	220 V		
K20704	220 V	•	Cod. 11134
20703	Petrol		
K20703	Petrol	•	Cod. 11134

F TECHNICAL DATA

	THOR
Version	Trolley
Max. delivery	7,5 l/m - 9 l/m Petrol
Max. working pressure	220 bar
Motor power	2,8 Kw
Voltage	110 VAC
	220 VAC
Weight	76 Kg - 125 Kg Petrol
Max. nozzle size	0,049" Paint
	0,051" Stucco

	THOR
Power generation	6 Kw single phase
Material outlet	3/8" NPT-NPSM
Sound pressure level	≤60 dB (A)
Minimum length (A)	700 mm
Minimum height (B)	1000 mm
Maximum length (C)	750 mm
Maximum height (D)	1100 mm
Width	720 mm

PARTS OF THE PUMP IN CONTACT WITH THE MATERIAL:

Stainless Steel AISI 420B, PTFE; Aluminium, Galvanised steel

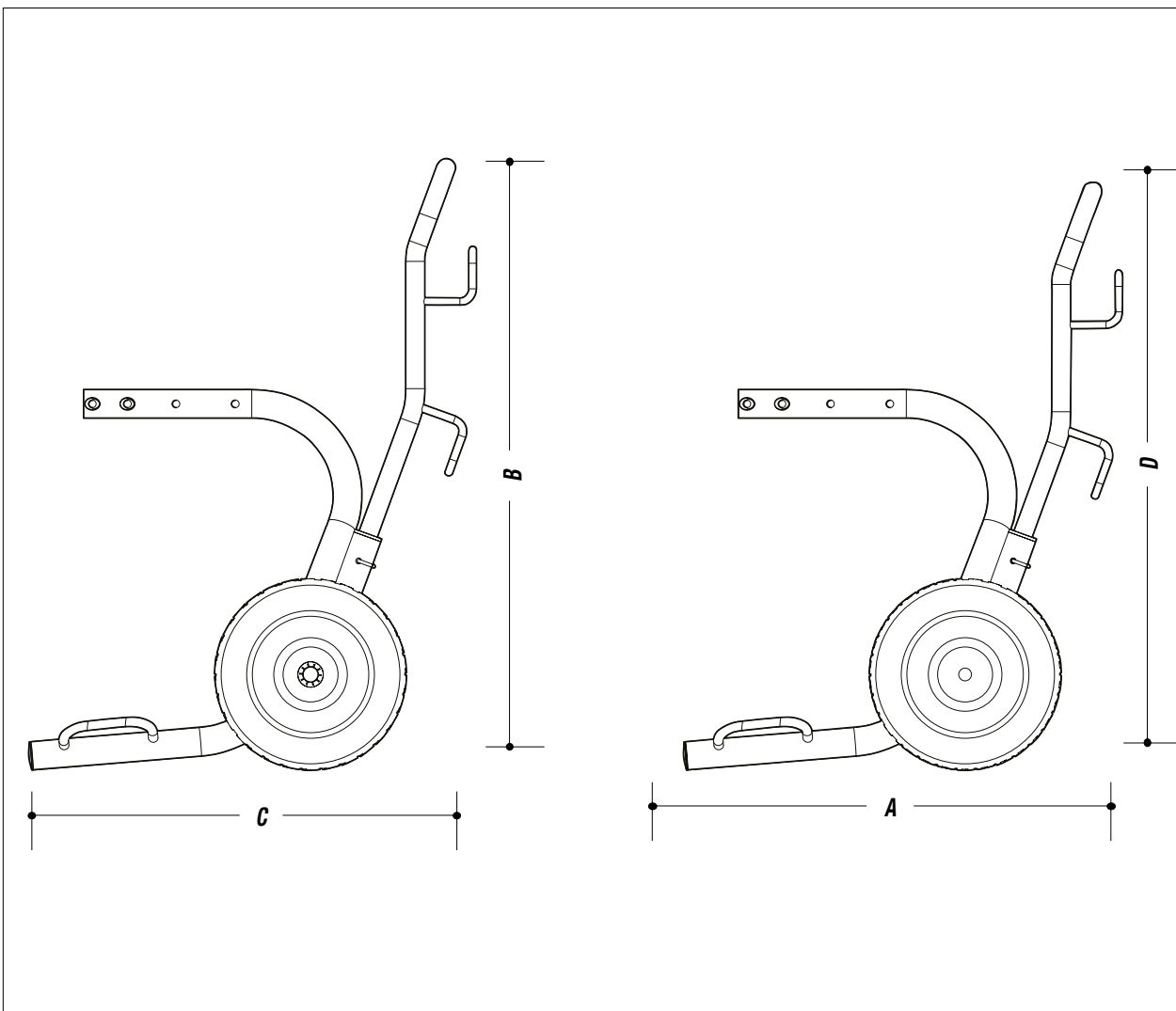

Fig. 1

G DESCRIPTION OF THE EQUIPMENT

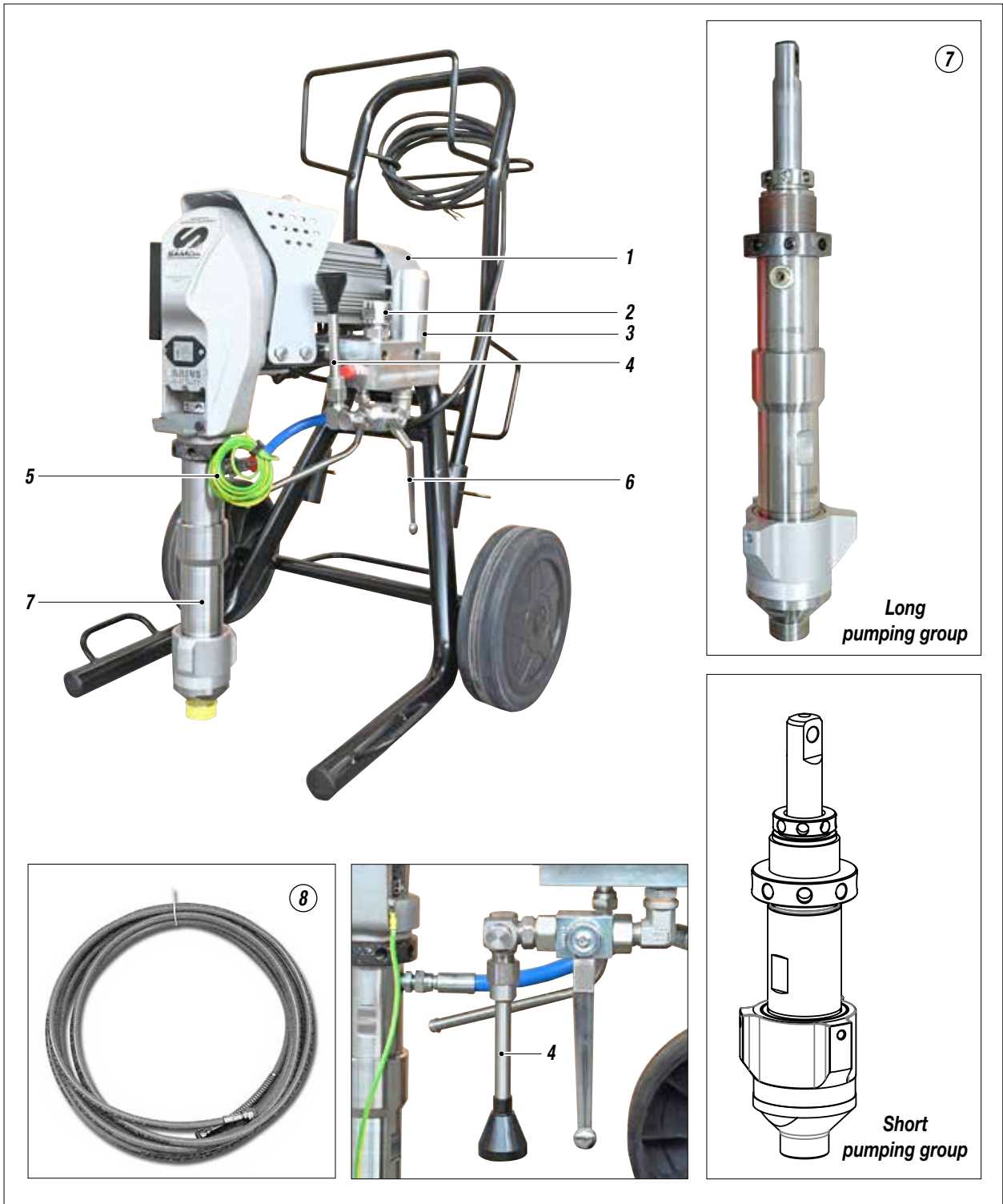

Fig. 1

Pos.	Description
1	Electric motor
2	Safety valve
3	Pressure transmitter
4	Recirculation tube

Pos.	Description
5	Earth cable with clamp
6	Recirculation valve
7	Pumping group
8	High pressure flexible pipe of compensation Ø3/8"

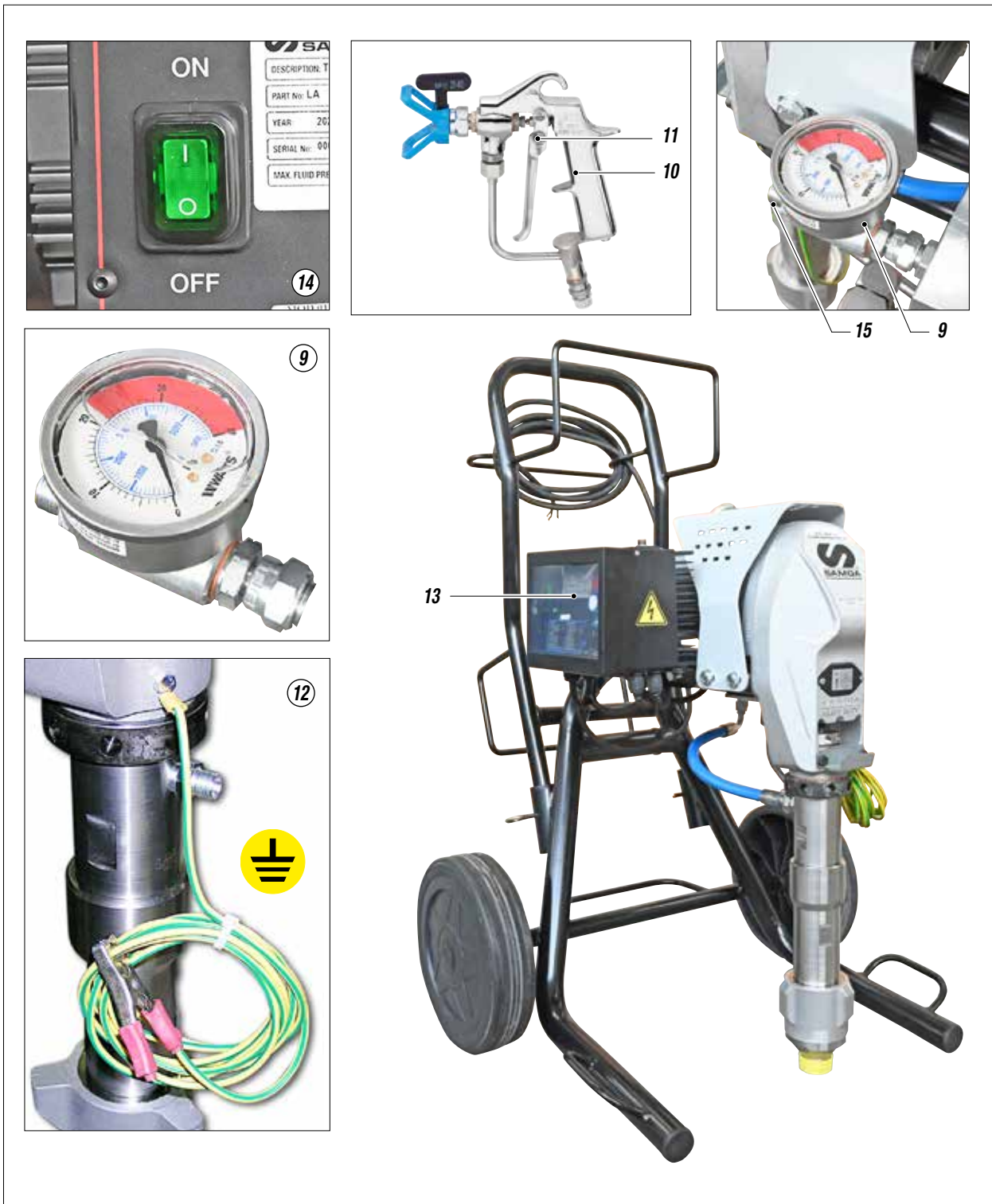

Fig. 2

Pos.	Description
9	Pressure gauge
10	Airless manual gun L91X
11	Trigger safety clamp
12	Earth cable with clamp

Pos.	Description
13	Control equipment
14	ON/OFF switch
15	Flexible pipe connection

ALARM MESSAGES

When the product to be applied is finished the pump “sucks air” and automatically switches to the minimum number of cycles. The alarm messages function is described on the area sign (6).

Each time key (8) is pushed, the messages are displayed on the screen (7).



When an alarm message has been indicated the machine has to be switched off and on again using switch (1).

Each time the machine is switched off, the condensers remain charged for about 5 minutes. To avoid risk of shock, when removing the electrical box wait until the condensers have discharged altogether.



Fig. 3

Pos.	Description
1	ON/OFF switch
2	Work pressure adjustment knob
3	Maximum pressure
4	Minimum pressure

Pos.	Description
5	Material circulation and machine washing position
6	Alarms
7	Message screen
8	Function keys

FUNCTIONS TABLE

Function symbol	Type of function	Description of functionw
P	Working pressure (bar)	Indicates the real time pressure used during the work cycle
J	Motor current (A)	Indicates the real time amperage on the equipment's motor during the work cycle
Pd	Pressure setting (bar)	Indicates the pressure set before the work cycle begins
c	Dissipator temp. (°C)	Indicates the dissipator temperature (in degrees Centigrade) during the work cycle
h	Working hours (h)	Indicates the total number of hours the equipment has worked

ALARM MESSAGE TABLE

Alarm symbol	Type of alarm	CAUSE	Solution
F1	Maximum current	The motor's current absorption is too high	Check the mechanical and hydraulic condition of the equipment. If necessary, take action
F2	Dissipator temp.	The dissipator temperature is too high	Check that the dissipator surfaces are clean and that the dissipator is properly ventilated
F3	Motor temp.	The motor temperature is too high	Check that the motor's heat dissipation surfaces are clean. Check that cooling ventilation is correct
F4	Maximum voltage	The voltage is too high	Check the connection to the electrical line and reinstate the correct nominal voltage
F5	Minimum voltage	The voltage is too low	Check the connection to the electrical line and reinstate the correct nominal voltage
F6	Earth connection	The earth connection is disconnected or non-existent	Check the earth cable and, if necessary, replace it. Make sure that the machine is earthed
F7	Pressure sensor missing	The pressure sensor is damaged or not fitted	Replace it
F8	Automatic switch-off during circulation phase (15 minutes)	The equipment is in cleaning mode	Wait until the equipment has stopped completely before using it for a new job

H SETTING-UP

CHECK ON POWER SUPPLY

 **Make sure that the electrical system is earthed and complies with regulations.**

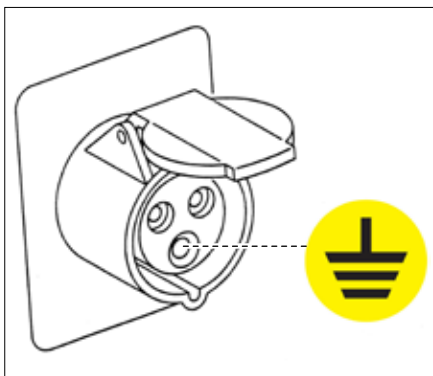

Fig. 2

- Check the mains voltage corresponds to the equipment's rating.



- The supply cable is provided without plug. Use a plug which guarantees the plant earthing. Only a technician or a skilled person should perform the connection of the plug to the electric cable.

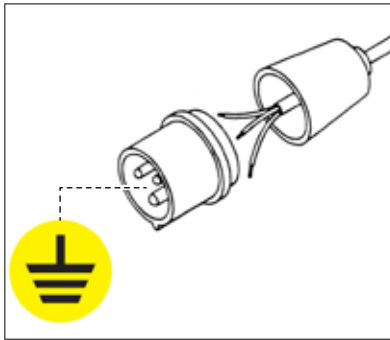

Fig. 3



Should anyone use an extension cable between the tooling and the socket, it must have the same characteristics as the cable supplied (minimum diameter of the wire 4 mm²) with a maximum length of 50 mt. Higher lengths and lower diameters can provoke excessive voltage falls and also an anomalous working of the equipment.

THOR equipment is fitted with an additional external earth cable that is connected to the stem on the pump unit by means of a specific clamp (4), in order to protect the operator against any risk of static or electric shock.

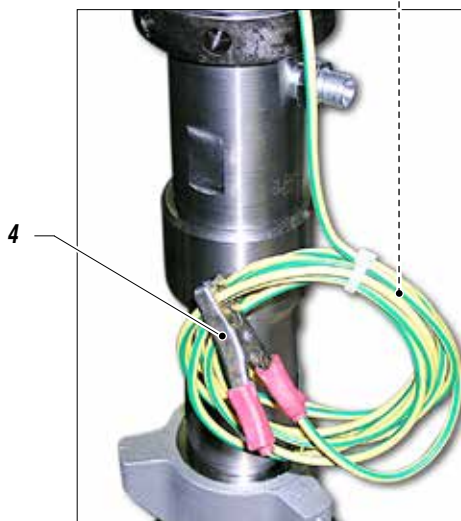

Fig. 4

To avoid electric shock when disassembling or checking the electronic equipment, wait 5 minutes after having disconnected the power supply cable, so that the electricity stored in the condensers while working can be dissipated.

Also check the condition of the earth cable to avoid any risk of shock.



Before carrying out any checks on the machine (maintenance, cleaning, or replacing parts) switch off the machine and wait until it has stopped altogether.



While checking stay away from electrical or moving parts to avoid any risk of shock or crushing of hands.



WARNING :

- DO NOT modify the plug for the earth socket in any way.
- ONLY use electrical connections that are earthed.
- Make sure that any earth extension cords are in good condition.
- ONLY use three-core extension cables.
- Avoid direct contact with the rain. Keep the equipment in a dry place.

CONNECTION OF THE FLEXIBLE HOSE TO THE GUN

- Connect the high pressure flexible hose (1) to the pump (2) and to the gun (3), ensuring to tighten the fittings (*the use of two wrenches is suggested*). NEVER use sealants on fittings' threads. It is recommended to use the hose provided with the standard kit (ref. 18036). NEVER use a damaged or a repaired flexible hose.
- It is recommended to use the hose provided with the standard kit (ref. 18036). NEVER use a damaged or a repaired flexible hose.

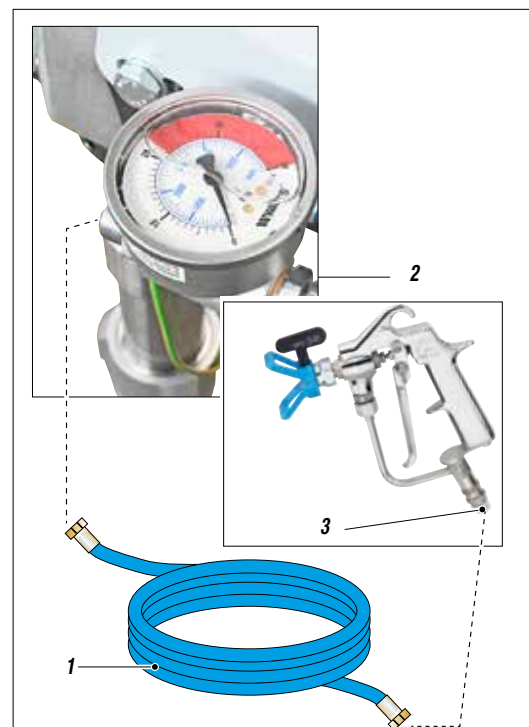

Fig. 5

CONNECTION OF THE TOOLING TO THE POWER SUPPLY

Before connection up the power supply to the equipment, make sure that the electrical system is earthed and complies with regulations.

Make sure that the clamp (4) provided is positioned correctly, in order to earth the pump unit in the equipment properly.

- Check the switch (5) is on the “OFF” (0) position before connecting the cable to the mains.
- Place the pressure control knob (6) on the “MIN” position (turn counterclockwise).

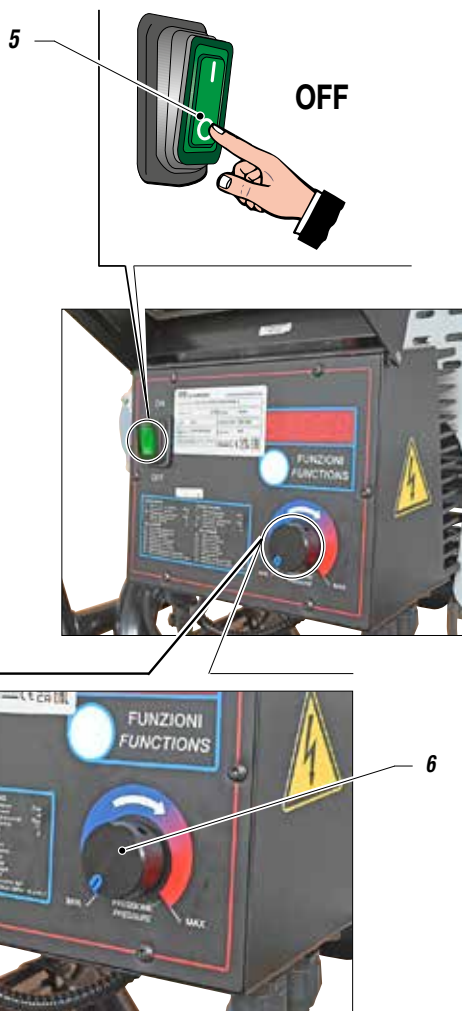

Fig. 6

WASHING OF THE NEW EQUIPMENT

- The equipment has already been adjusted at our factory with light mineral oil left inside the pumping group as protection. Therefore, wash with diluent before sucking the product.

- Lift the suction unit and immerse it in the bucket that contains the washing liquid.
- Connect the clamp to an earthing point.



Fig. 7

- Ensure the gun (3) is without nozzle.

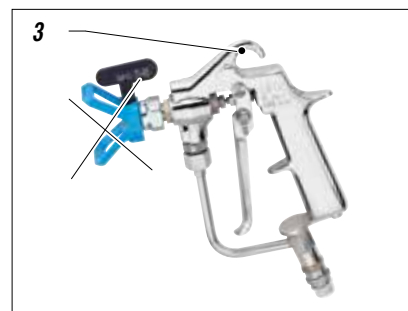

Fig. 8

- Press the switch (5) of the equipment “ON” (I).

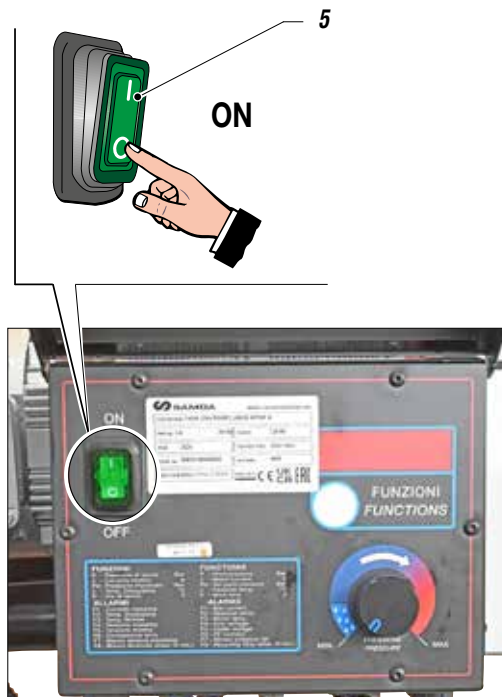

Fig. 9

- Turn the pressure setting knob (6) clockwise to the “CIRCULATION & WASHING” position (*drop symbol*).

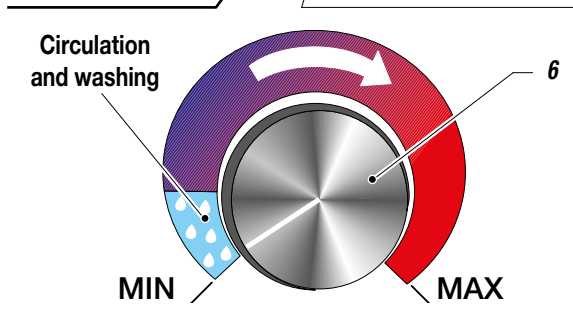

Fig. 10



Hold the spray gun against the edge of the metal contained (7).

- Point the spray gun into the collection container (7) and hold the trigger down (*in order to expel the oil contained*) until clean liquid flows out. Now, release the trigger.



Use a metal container (7).

To avoid any risk of electric shock connect the collection container to a surface that is earthed (e.g. concrete) and not to surfaces that will insulate the container from the earth.



- Remove the suction hose and remove the bucket of cleaning liquid.
- Now point the spray gun (3) into the container (7) and press the trigger to recover any cleaning liquid left.
- As the pump idles, press the “OFF” (0) switch (5) to stop the tooling. When this is complete, release the trigger.

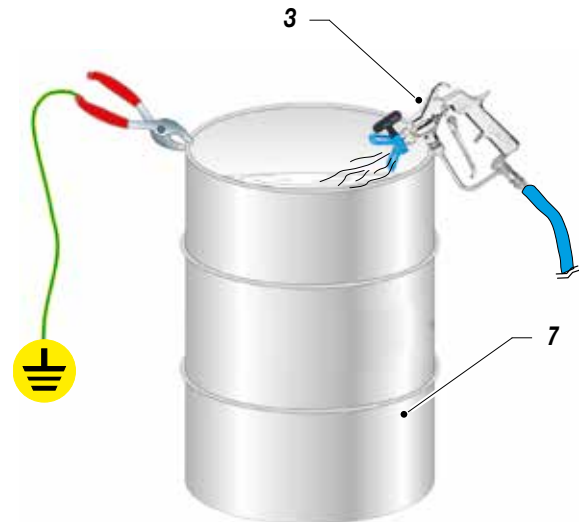

Fig. 11

Absolutely avoid to spray solvents indoors. In addition, it is recommended to keep away from the pump in order to avoid the contact between the solvent fumes and the electric motor.



For disposing of the washing liquid, see the requirements laid down in the Standards in force in the country in which the equipment is used and act accordingly.



The Client is solely responsible for any irregular action taken before, during, or after disposing of washing liquid, or in interpreting and applying the current Standards in this regard.

- Now the machine is ready. When water-based paint has been used, in addition to washing using the cleaning liquid, we recommend washing with soapy water and then clean water.

PREPARING THE PRODUCT



Make sure the product is suitable to be used with an airless spray gun.

- Mix and filter the product before using it.



Make sure the product to be used is compatible with the materials employed for manufacturing the equipment (stainless steel and aluminium). Because of that, please contact the supplier of the product.

Never use products containing halogen hydrocarbons (as *methylene chloride*). If these products come into contact with aluminium parts of the equipment, can provoke dangerous chemical reactions with risk of explosion.



REMOVE THE FILTER (9) FOR DENSE PRODUCTS.

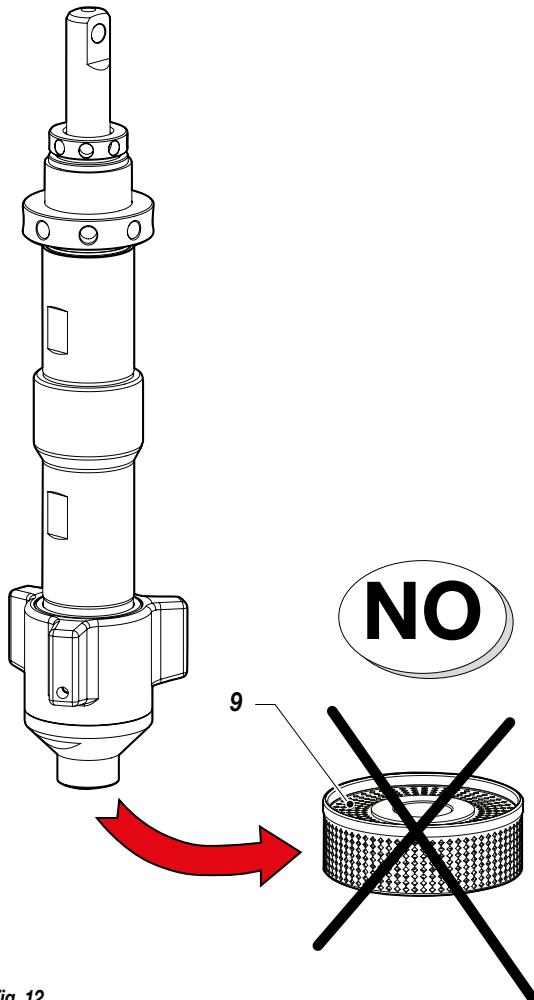

Fig. 12

I WORKING

START OF THE WORKING OPERATIONS



Make sure that the electrical system is earthed and complies with regulations.
 Make sure that the earth clamp is positioned correctly to ensure a safe earth on the pump unit.

- Use the tooling after performing all the **SETTING UP** operations above described.

- Dip the suction pipe (1) into the product tank.



Fig. 1

- With the short pumping group, connect all hoses as shown in Figure 2.



Fig. 2

- Open the recycling tap (3).

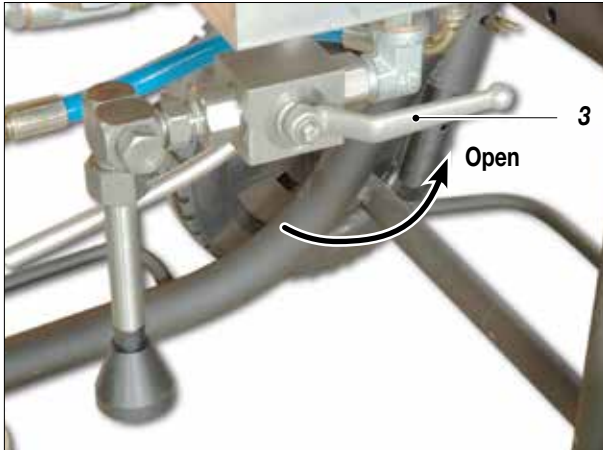

Fig. 3

- Press the switch (4) "ON" (I) of the equipment.

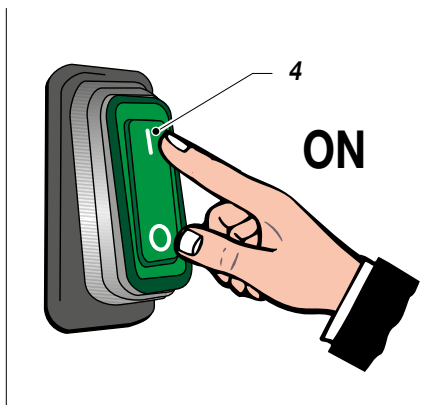

Fig. 4

- Turn the pressure setting knob (5) clockwise to the "CIRCULATION & WASHING" position (drop symbol).

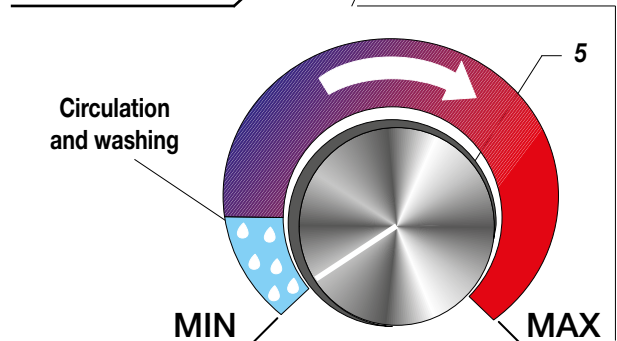

Fig. 5

- Make sure that the product circulates through the circulation hose (6).
- Close the circulation tap (3).

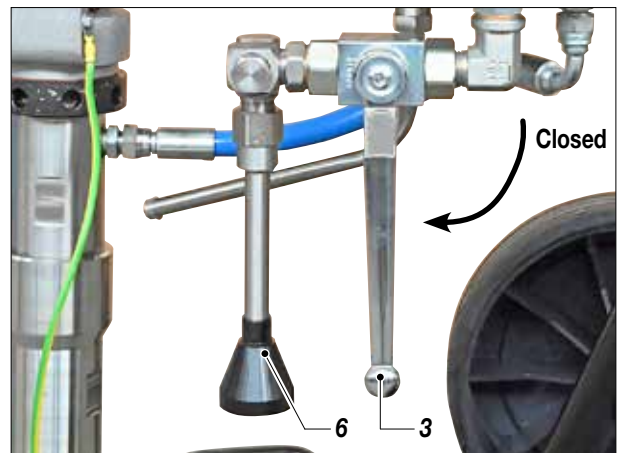

Fig. 6

- The machine continues to suck up product until it has filled the hose as far as the spray gun, after which it will automatically stop when the set pressure is reached.

SPRAY ADJUSTMENT

- Slowly turn clockwise the pressure control knob (5) to reach the pressure value in order to ensure a good atomization of the product.

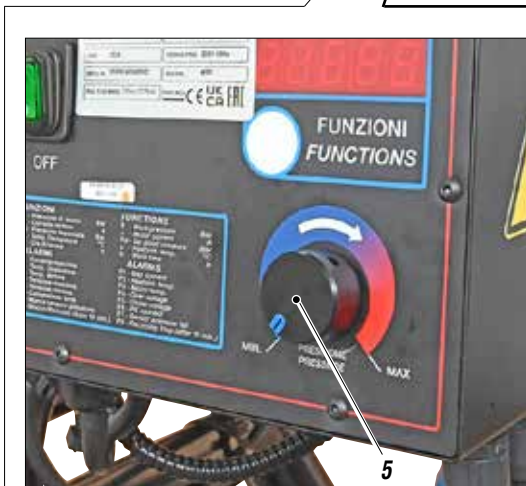

Fig. 7

- An irregular and marked spray on the sides indicates a low working pressure. On the contrary, a too high pressure causes a high fog ("overspray") and waste of product.
- In order to avoid overthickness of paint, let the gun advance sideways (*right-left*) when spraying.
- Always paint with regular parallel bands coats.
- Keep a safety and constant distance between the gun and the support to be painted and also keep yourselves perpendicular to it.



Safety valve: when working at the maximum pressure available, releasing the gun trigger sudden increases of pressure can occur. In this case, the safety valve (6) opens automatically eliminating part of the product from the recirculating tube (6). Then it closes so as to go back to the first working conditions.



Safety valve: when working at the maximum pressure available, releasing the gun trigger sudden increases of pressure can occur. In this case, the safety valve (7) opens automatically eliminating part of the product from the recirculating tube (6). Then it closes so as to go back to the first working conditions.

The valve (7) serves two purposes:

- Safety:** It opens the passage at pressure peaks exceeding 280-300 bar;
- Regulation:** It returns the working pressure to 250 bar and levels out the hydraulic operating hysteresis.

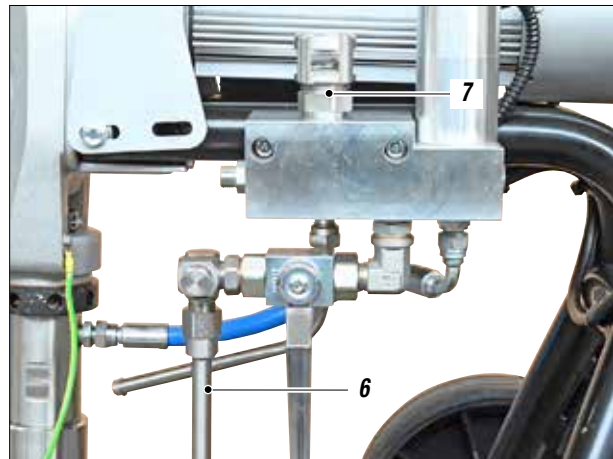

Fig. 8

J CLEANING AT THE END OF THE WORK

CLEANING FOR SOLVENT-BASED PRODUCTS



Make sure that the electrical system is earthed and complies with regulations.

- Reduce pressure to the minimum (turn counterclockwise the pressure control knob (1)).
- Press the switch (2) placed on the box of the electric motor, to stop the equipment.

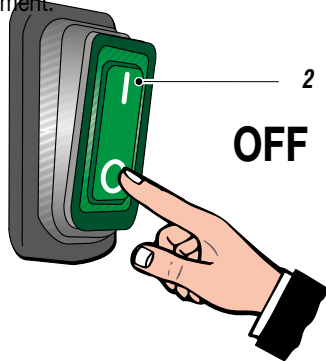

Fig. 1

- Hold the spray gun trigger down.
- Open the circulation tap (3) to discharge the pressure in the circuit.

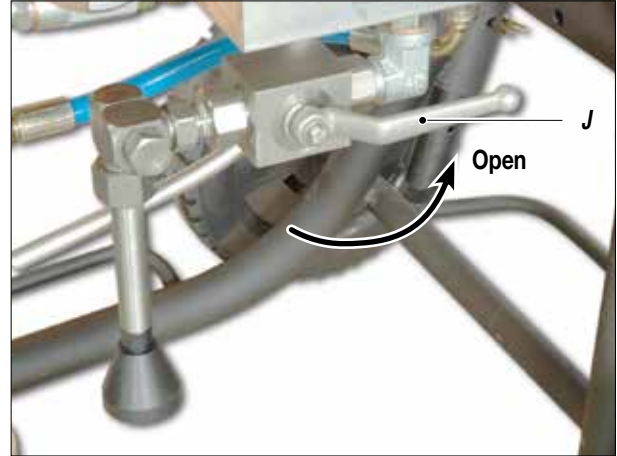

Fig. 2

- Lift the suction hose and replace the bucket containing the product with a bucket of cleaning liquid (make sure it is compatible with the product you are using).
- Unscrew the nozzle on the spray gun (remember to clean it with cleaning liquid).
- Press the switch (2) "ON" (I) of the equipment.

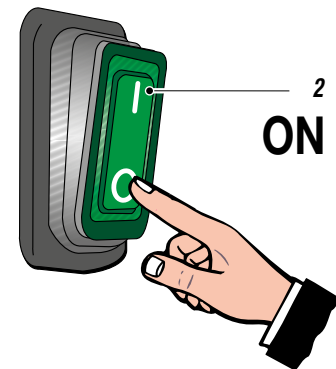

Fig. 3

- Turn the pressure setting knob (1) clockwise to the “CIRCULATION & WASHING” position (drop symbol).

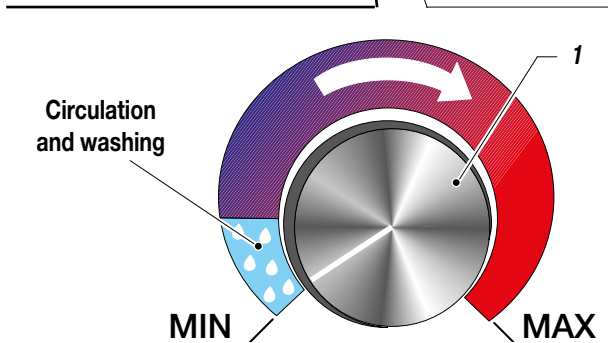



Fig. 4

- Make sure that the product circulates through the circulation hose.

 **Make sure that the machine sucks in clean washing liquid. Allow the cleaning liquid to discharge into another container and do not mix it with the cleaning liquid still to be used. We recommend circulating the cleaning liquid for at least 15 minutes.**

 **For disposing of the washing liquid, see the requirements laid down in the Standards in force in the country in which the equipment is used and act accordingly. The Client is solely responsible for any irregular action taken before, during, or after disposing of washing liquid, or in interpreting and applying the current Standards in this regard.**

- Close the circulation tap (J3).

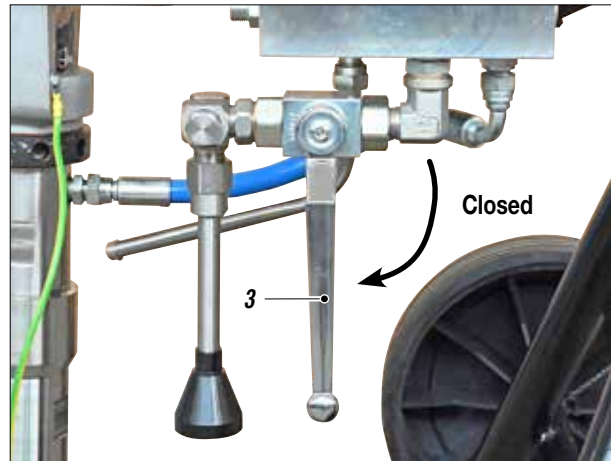





Fig. 5

- Point the spray gun (4) into the container (5) used to collect the cleaning liquid and hold the trigger down to expel any product remaining, until clean liquid flows out. Now, release the trigger.

 **Hold the spray gun against the edge of the metal contained (5).**

 **Use a metal container (5). To avoid any risk of electric shock connect the collection container to a surface that is earthed (e.g. concrete) and not to surfaces that will insulate the container from the earth.**



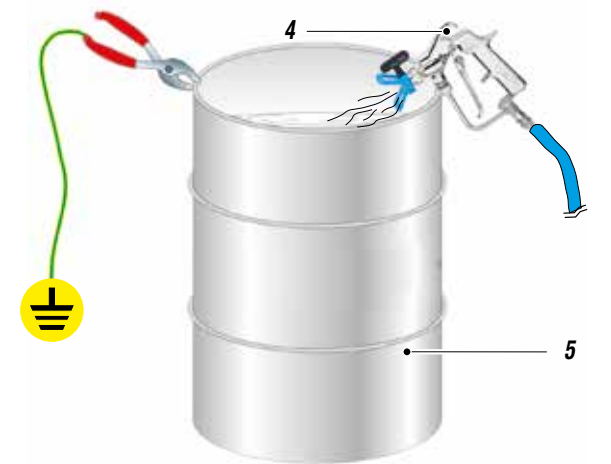

Fig. 6

- Lift the suction hose and remove the bucket of cleaning liquid.
- Now point the spray gun (4) into the container (5) and press the trigger to recover any cleaning liquid left.

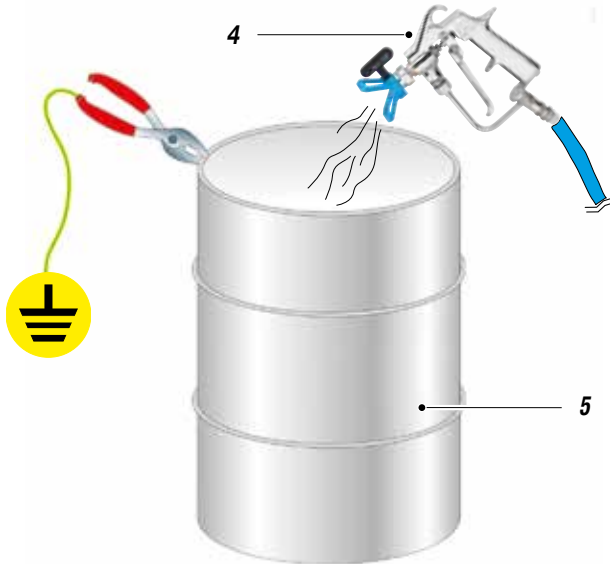

Fig. 7

- As the pump idles, press the “OFF” (0) switch (2) to stop the tooling.

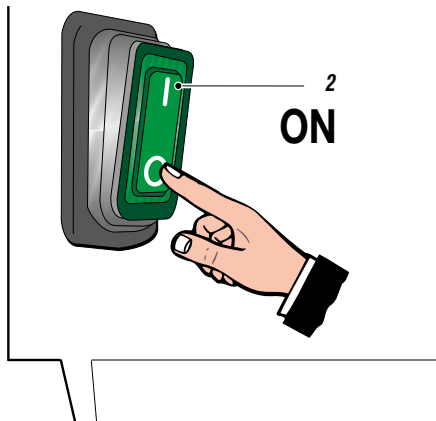

Fig. 8

- In case of long storage, we recommend you to suck and to leave light mineral oil inside the pumping group and the flexible hose.



Follow the washing procedure before using again the equipment.

- Take the cleaning liquid and store it in suitable containers.



Make sure that the machine sucks in clean washing liquid. Allow the cleaning liquid to discharge into another container and do not mix it with the cleaning liquid still to be used. We recommend circulating the cleaning liquid for at least 15 minutes.

- Disassemble the circulation hose (6), clean thoroughly, and reassemble everything in the reverse order compared to disassembly.

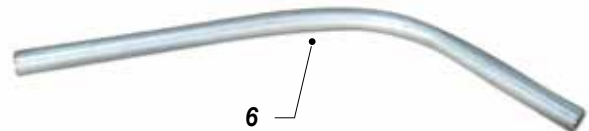
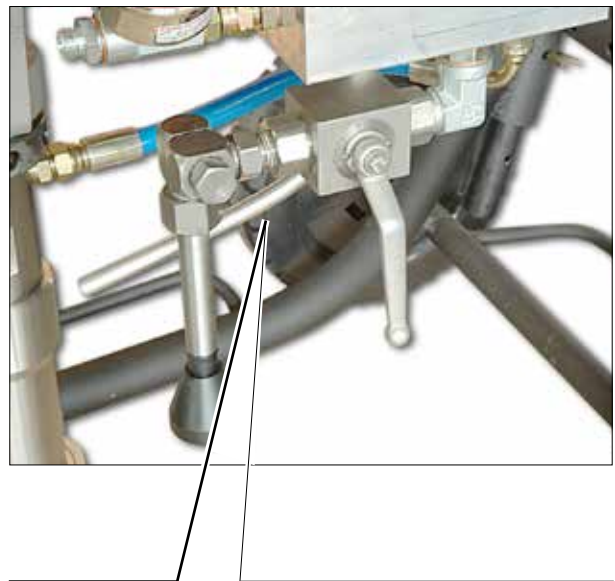

Fig. 9

- When washing heavy products (such as gypsum, etc.), we recommend washing with running water that is not stored, in order to avoid deposits inside the equipment.

CLEANING FOR WATER-BASED PRODUCTS



Make sure that the electrical system is earthed and complies with regulations.

- Reduce pressure to the minimum (turn counterclockwise the pressure control knob (1)).



Fig. 11

- Press the switch (J2) placed on the box of the electric motor, to stop the equipment.

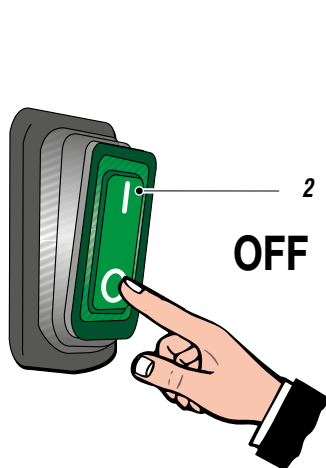

Fig. 12

- Hold the spray gun trigger down.
- Open the circulation tap (3) to discharge the pressure in the circuit.

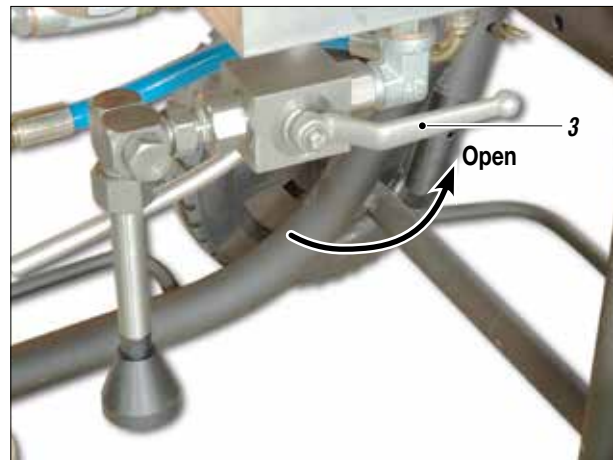

Fig. 13

- Lift the suction hose and replace the bucket of product with an empty bucket (8).
- Connect a rubber hose (9) to a water tap (10) and fill the bucket (8).
- Position an empty bucket to collect the water (11) under the circulation hose (12).
- Press the switch (2) su ON (I) ON (I) and turn a little the pressure control knob (1) clockwise so as the machine works till the motor starts.

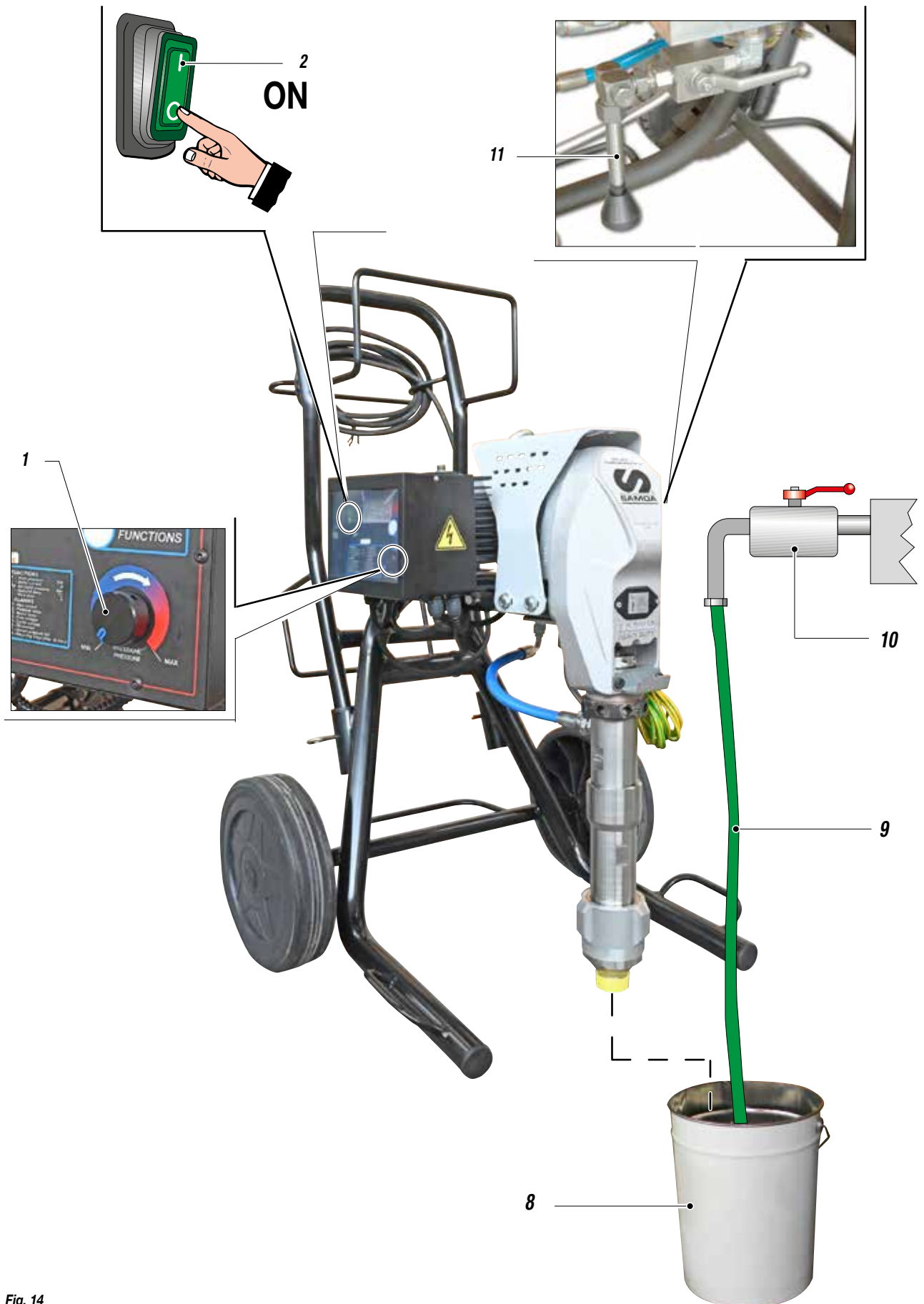

Fig. 14

- Run the pump's washing cycle until clean water flows out of the circulation hose (11).
- Close the circulation tap (3).

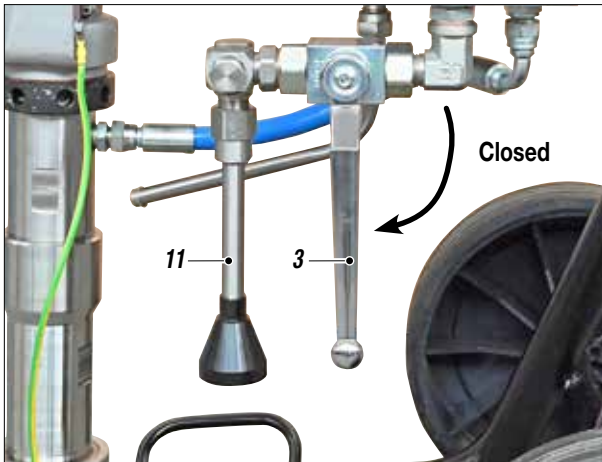

Fig. 15

- Remove the suction hose and the rubber hose (9) and take away the bucket of water (8).
- Now point the spray gun (4) into the container (5) and press the trigger to recover any cleaning liquid left.

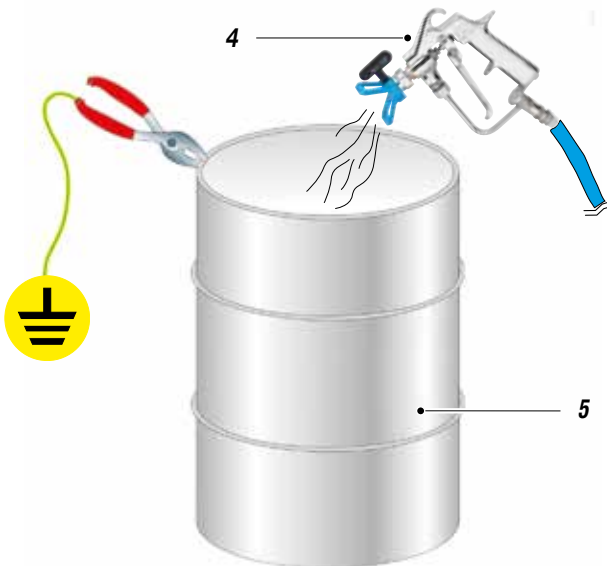

Fig. 16

- As the pump idles, press the "OFF" (0) switch (2) su OFF (0) to stop the tooling.

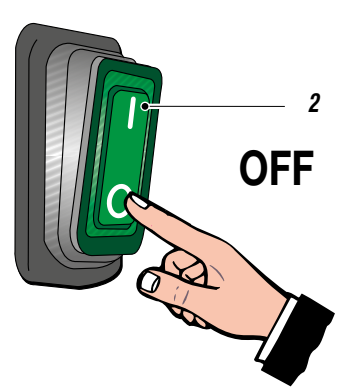

Fig. 17

- In case of long storage, we recommend you to suck and to leave light mineral oil inside the pumping group and the flexible hose.



Follow the washing procedure before using again the equipment.



If the equipment is to be stopped for a lengthy period of time, carry out the cleaning operations described previously, according to the type of product used.
In case of short stoppages, suck in some water and leave the pump unit in the bucket (8) for a few minutes.

K ROUTINE MAINTENANCE

CHECK ON THE PACKING NUT

The gaskets do not need adjusting. The ring nut is only used to fit and remove gaskets and for topping up the oil.



Always disconnect the electrical supply and discharge the pressure in the pump unit (*open the discharge valve*) before carrying out any maintenance.

Wait 30 seconds before proceeding with maintenance operations to allow any residual electricity to be discharged.

- Use the lubricant (1) provided (ref. 16340) to make it easier to slide the piston inside the seal pack and to substitute the air with oil.
- At the start of each working day check that the ring nut is full of hydraulic oil (Ref. 16340). This oil makes it easier for the piston to slide and prevents any material that escapes via the seal gasket drying when the equipment is stopped.



Fig. 1

- The ring nut (2) must be tightened all the way. Every 100 working hours, with the pressure at 0 bar, check that it is tightened all the way.
- The pin (3) supplied (Ref. 20144) is used to tighten and open the pump unit locking ring nut, which must always be tight to act as a locknut.

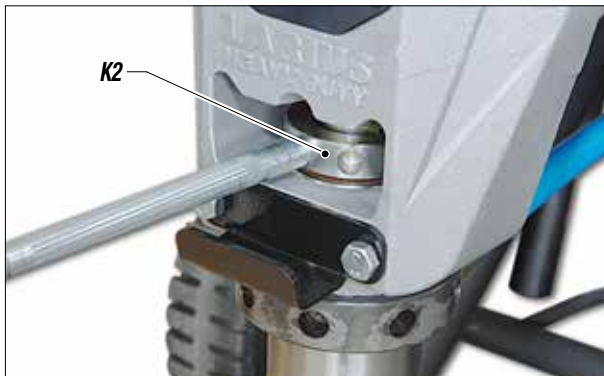

Fig. 2

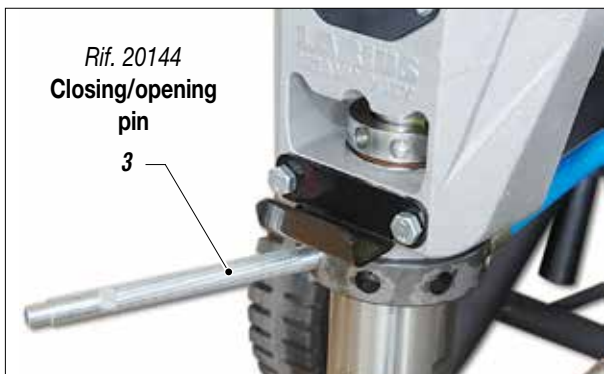

Fig. 3

CHECKING THE HEAT EXCHANGE RADIATOR

Always keep the heat exchange radiator (4) on the electronic control box clean, in order to guarantee correct heat exchange with the ambient air.

We suggest cleaning using a jet of compressed air.

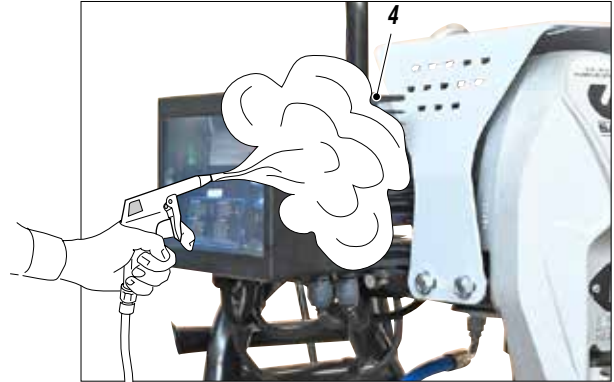

Fig. 4

CHECKING THE SEAL GASKET (O-RING)

Check that no material is escaping from the safety hole (5) at the bottom of the protective container.

If necessary, replace the O-Ring for the pressure sensor.

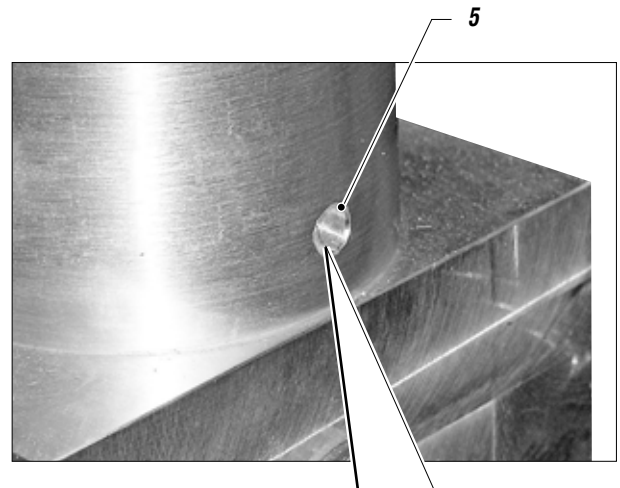
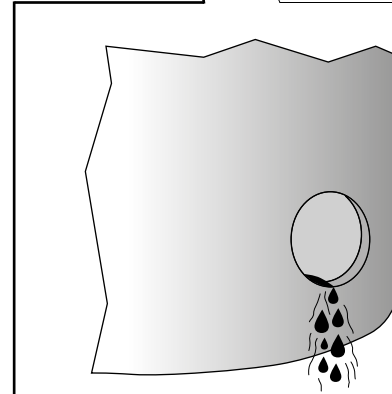

Fig. 5



REDUCTION BOX GREASING

After 100 hours of operation or when you hear a change in the noise on the gearbox, lubricate using the grease nipple, removing the sheet covering the injection nipple.

1- Remove the rear screws (6) and loosen the front screws (7) on the cover (8).

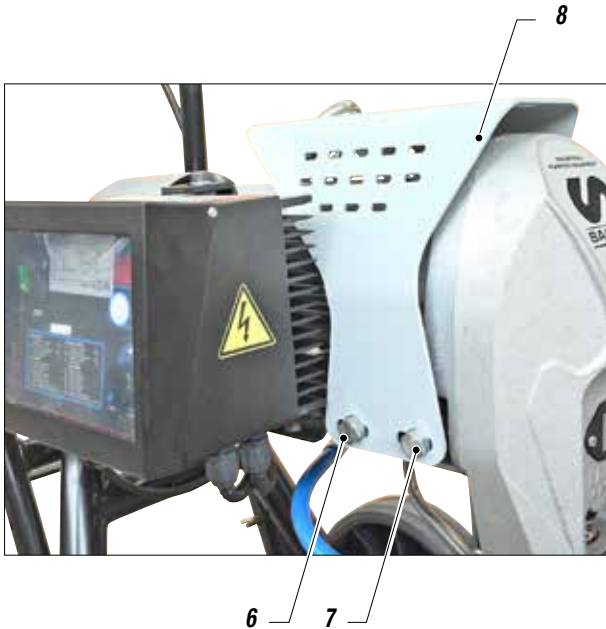

Fig. 6

2- Rotate the cover (8) forward.



Fig. 7

3- Grease with a grease pump using the nipple (9).

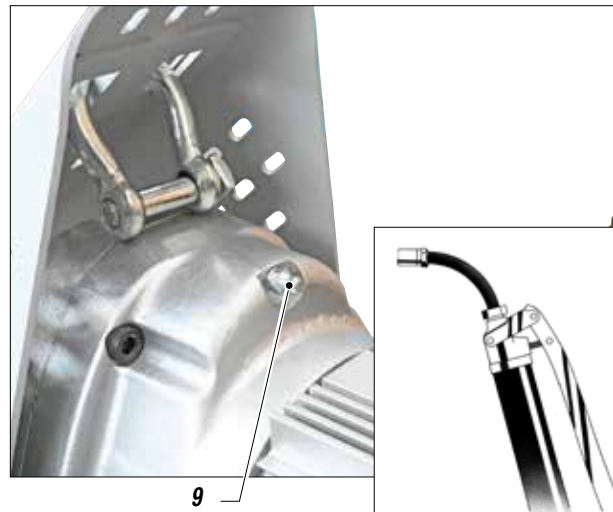

Fig. 8

4- Rotate, closing the cover (8), re-tighten the rear screws (6) and tighten the front screws (7) on the cover.



Fig. 9

L PROBLEMS AND SOLUTIONS

Problem	Cause	Solution
The equipment does not start	Lack of voltage;	Check the correct connection to the power supply;
	Considerable drops in mains voltage;	Check the extension cable;
	On/Off switch disconnected;	Ensure the On/Off switch is on the “on” position and turn clockwise the pressure control knob;
	Breakdown of pressure transmitter;	Verify and replace it, if necessary;
	Breakdown of motor electric control box;	Verify and replace it, if necessary;
	The line of material coming out of the pump is already under pressure;	Open the drain valve to release pressure in the circuit;
	The product is solidified inside the pump;	Open the drain valve to release pressure in the circuit and stop the machine. Disassemble the pumping group and the pressure transmitter and clean;
The equipment does not suck the product	Suction filter clogged;	Clean or replace it;
	Suction filter too fine;	Replace it with a larger-mesh filter (with very dense products, remove the filter);
	The equipment sucks air;	Check the suction pipe;
The equipment sucks but does not reach the pressure desired	Lack of product;	Add the product;
	The equipment sucks air;	Check the suction pipe;
	The drain valve is open;	Close the drain valve;
	The gaskets of the pumping group are worn;	Replace the gaskets;
	Suction or delivery valve dirty;	Disassemble the pumping group;
When pressing the trigger, the pressure lowers considerably	Nozzle too big or worn;	Replace it with a smaller one;
	The product is too dense;	Dilute the product, if possible;
	The filter of the gun-butt is too fine;	Replace it with a larger-mesh filter;
The pressure is normal but the product is not atomized	The nozzle is partially clogged;	Clean or replace it;
	The product is too dense;	Dilute the product, if possible;
	The filter of the gun-butt is too fine;	Replace it with a larger-mesh filter;
The atomization is imperfect	The nozzle is worn;	Replace it;
When releasing the trigger of the gun, the equipment does not stop (the motor runs slowly and the piston rod keeps on going up and down)	The gaskets of the pumping group are worn;	Replace the gaskets;
	Suction or delivery valve dirty;	Disassemble the pumping group and clean;
	Drain valve defective;	Verify and replace it, if necessary;
Material escaping from the cap	Material leaking from the O-Ring.	Replace the O-Ring.



Always close the air compressed supply and unload the plant pressure before performing any check or replacement of pump parts (see “correct procedure of decompression”).

M CORRECT PROCEDURE OF DECOMPRESSION



Make sure that the electrical system is earthed and complies with regulations.

- Zero the pressure regulator knob.
- Move the switch (1) to the **OFF (0)** position to stop the equipment.
- Open the discharge tap (2) to discharge the residual pressure, always turning it anticlockwise.
- Point the gun at the tank (3) of the product and press the trigger to release pressure. At the end of the operation, insert the gun clamp (4).

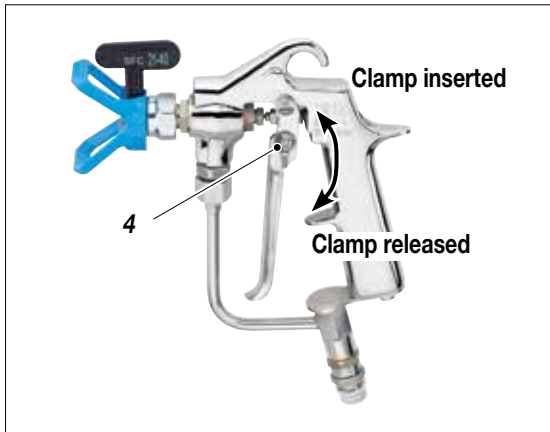

Fig. 1

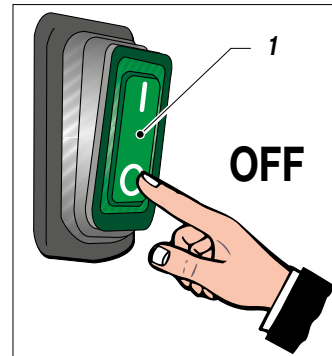

Fig. 3

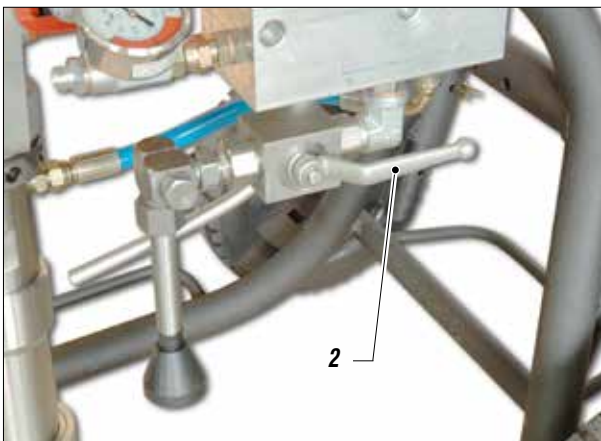

Fig. 2

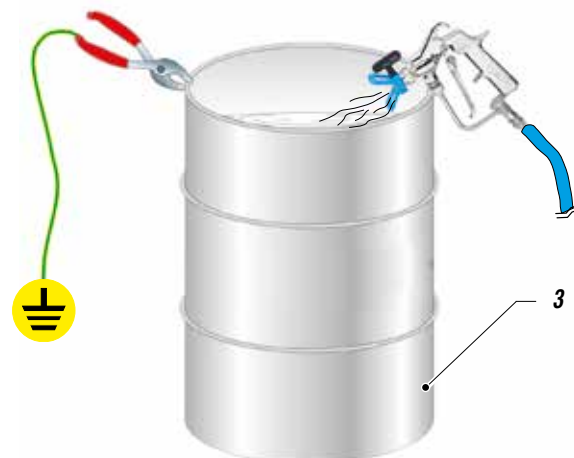

Fig. 4



WARNING :

If the equipment is still under pressure after performing the operations above described because of the nozzle or the flexible hose clogged, proceed as follows:



- Loosen very slowly the gun nozzle.
- Release the clamp.
- Point the gun at the container of the product and press the trigger to release pressure.
- Loosen very slowly the fitting of connection from the flexible hose to the gun.
- Clean or replace the flexible hose and the nozzle.

N REPLACEMENT OF THE PUMPING GROUP'S GASKETS

Each time you use the machine, check for material leaking from the top of the ring nut.

If any material leaks out when the pump is working at the set pressure, proceed as follows:

- Carry out this operation after cleaning the tooling.



Always disconnect the power supply and release pressure before going on with the operations (follow the "correct procedure of decompression").



The gaskets are self-adjusting. If a leak occurs they must be replaced.

- Disconnect the product feed hose (1) from the pump unit by unscrewing the nut (2).
- Unscrew the fixing ring nut (3) using the relevant closing pin (Ref. 20144).

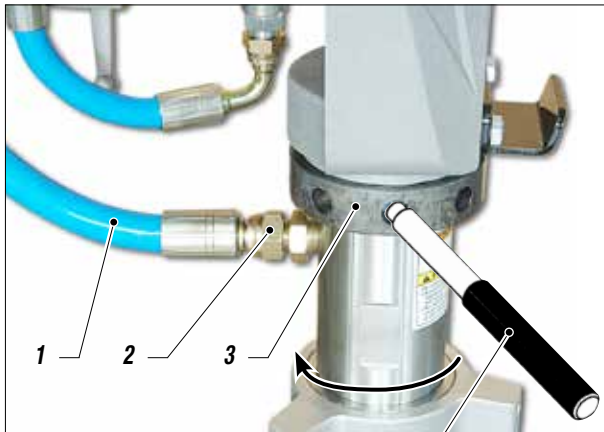

Fig. 1

Rif. 20144

- Remove the plastic cover (4) and screw the tool supplied (5) into the threaded hole in the seal pin (6).

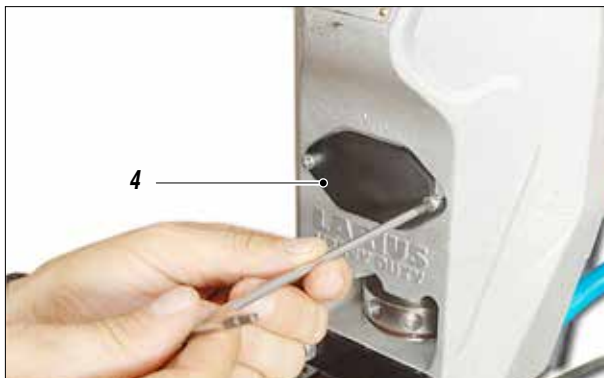

Fig. 2



Fig. 3

- Using a screwdriver (7), turn the motor (8) till the piston rod is on its stroke lowest point.

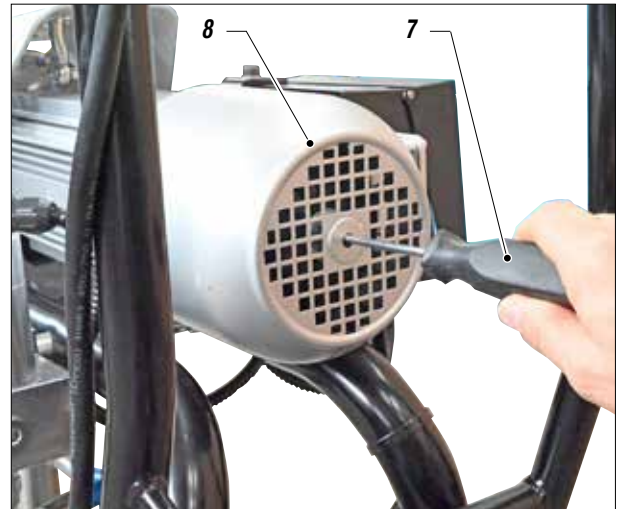

Fig. 4

- Remove the pin (6) from its seating.



Fig. 5

- Unscrew the pump unit (9) from its housing, as indicated.



Fig. 6

PIT STOP MAINTENANCE

Replacement of upper and lower gaskets 20 minutes.

- Grip the lower pump unit casing (9) in a vice and unscrew it using a size 60 spanner;

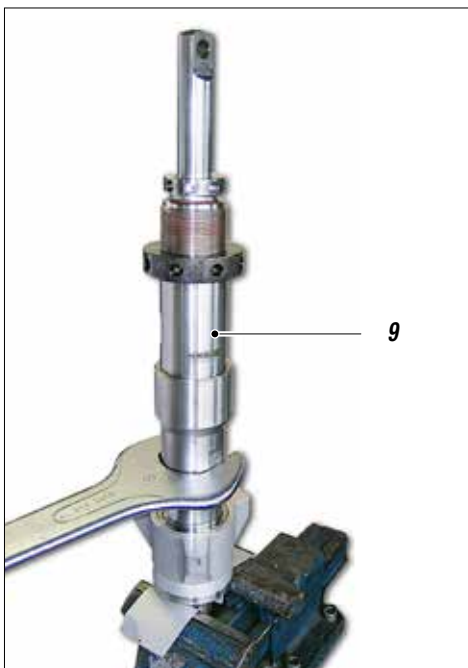

Fig. 7

Lower seal

- Remove the piston stem (10) and remove the pump unit sleeve (11);

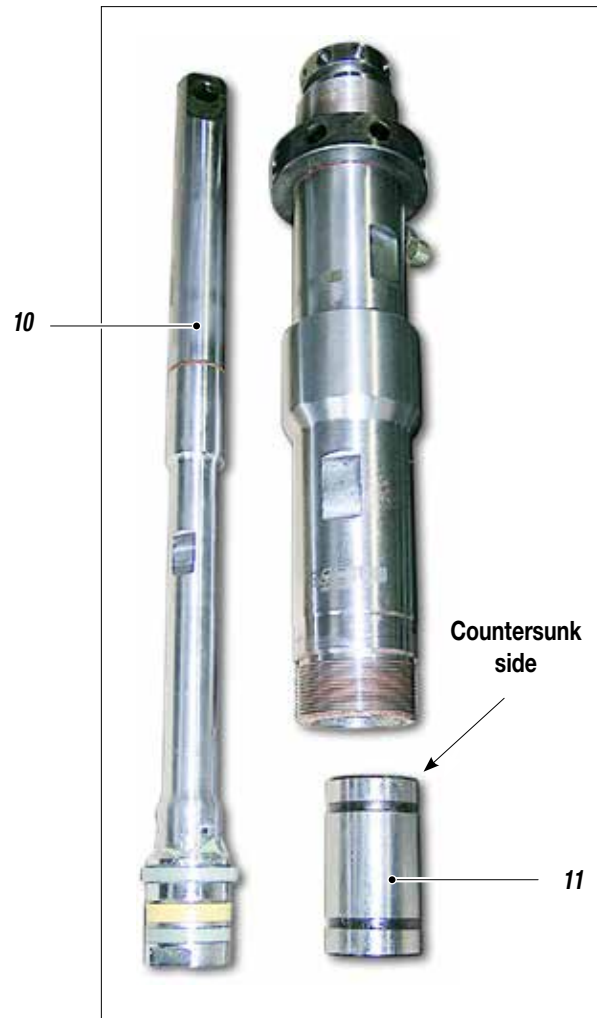

Fig. 8

- Grip the stem valve (12) in a vice;

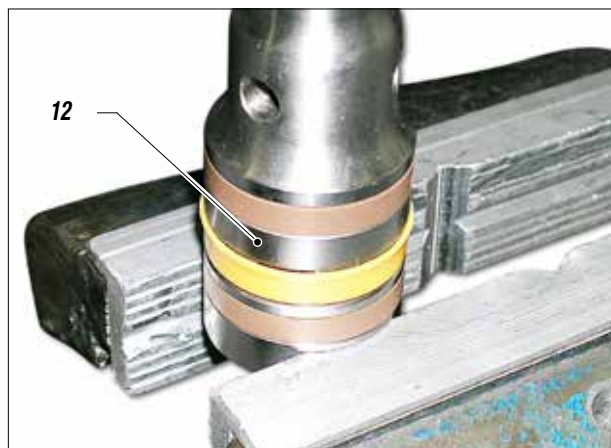

Fig. 9

- Use a size 22 spanner to unscrew the lower stem (13);

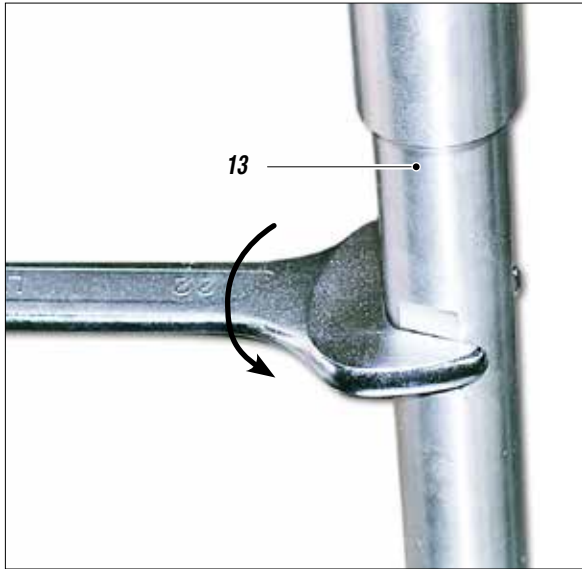

Fig. 10

- Use a screwdriver to remove the two split ring gaskets (14) and replace them;

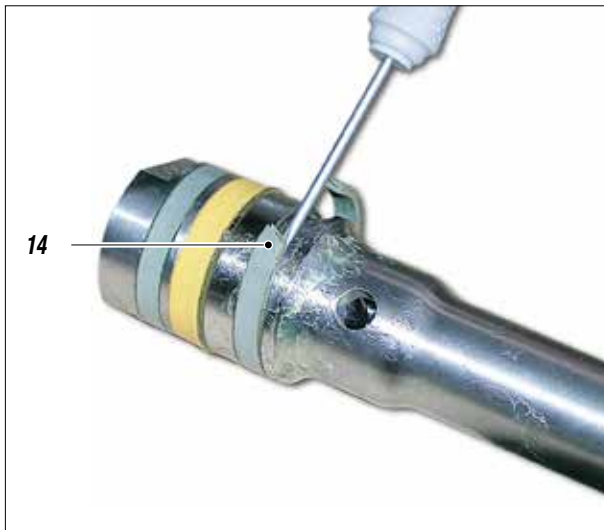

Fig. 11

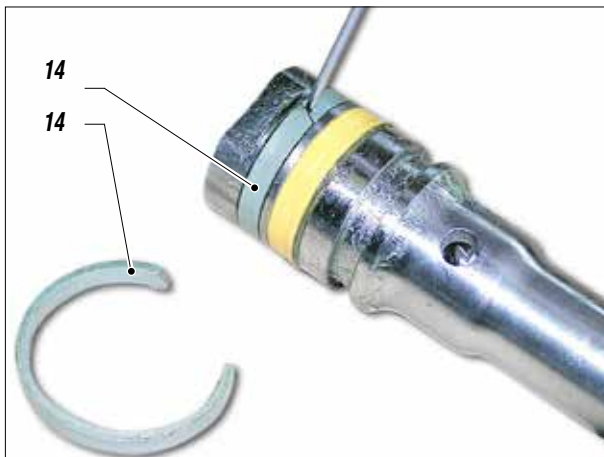

Fig. 12

- Unscrew the stem valve (15) altogether, check the surface of the ball seating (16) that comes into contact with the ball (17).
If worn, replace them;

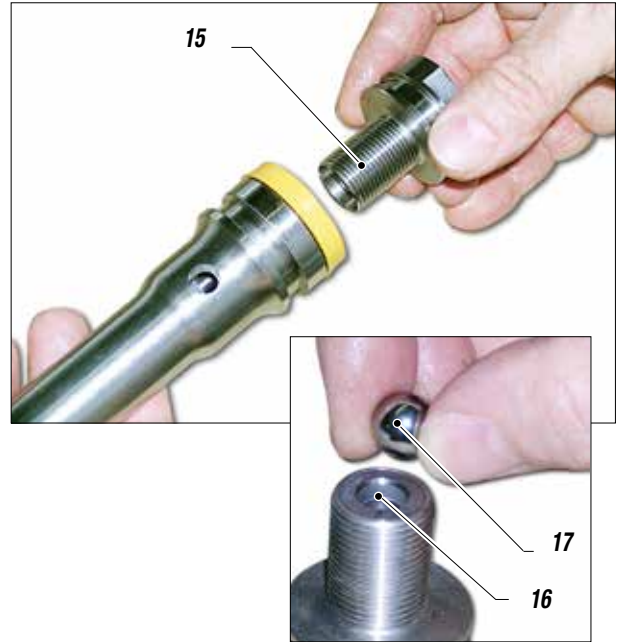

Fig. 13

- Use a screwdriver to remove the O-Ring (18) and replace it making sure it is aligned correctly (as illustrated);



Fig. 14

- Screw the valve stem (15) (Ref. 20139) on again and tighten fully, gripping the valve in a vice.
To tighten, use a 22 mm spanner;



Fig. 15

Upper seal

- Remove the ring nut (19);

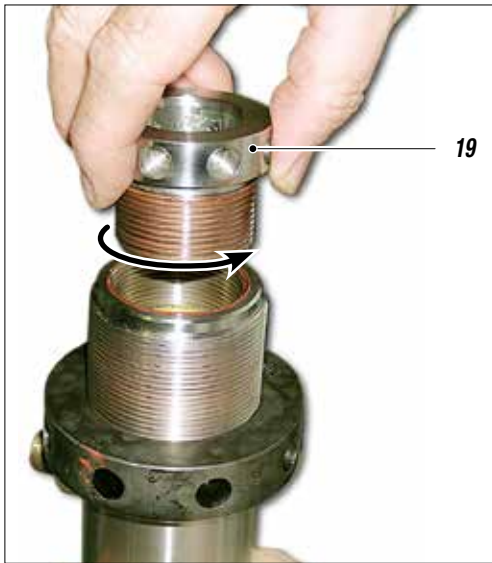

Fig. 16

- Remove the O-Ring (20);



Fig. 17

- Use a screwdriver to remove the O-Ring (21), and replace it with a new one;



Fig. 18

- Use a screwdriver to remove the O-Ring (22);



Fig. 19

- Use a screwdriver to remove the second O-Ring (23) located under the O-Ring (22) and insert a new O-Ring (23) in the same position;



Fig. 20



Positioning the ring (22) requires particular care during refitting.

- Assist insertion by applying leverage to the outside of the ring (22), pushing from the outside inwards and helping the ring to lodge in the seating, while being careful not to damage the ring's contact surfaces. Lubricate with grease before fitting.

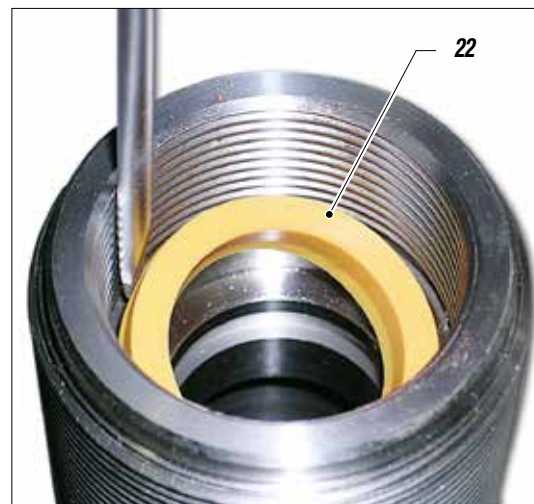

Fig. 21

- Remove the O-Rings (24 and 27) from the foot valve (25) and the O-Ring (26) and replace if necessary. Refit the components in the correct order (as indicated in the photo);

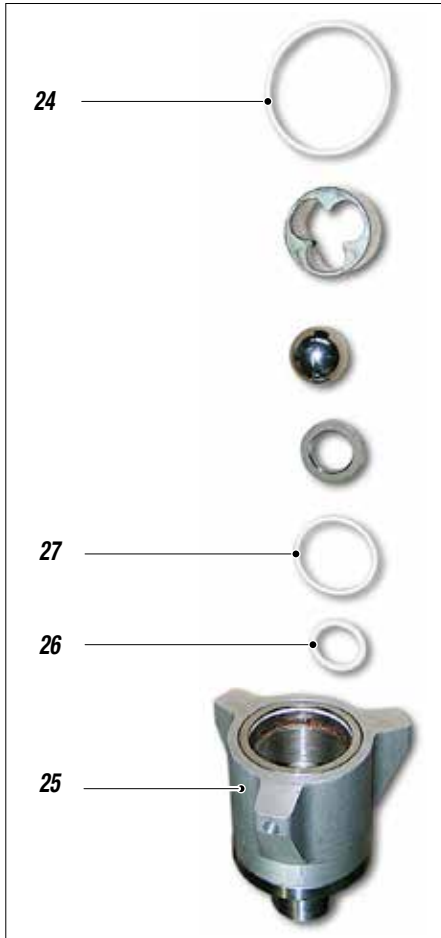

Fig. 22N



The ball seating (16) is countersunk on one side, where the ball (17) must sit.

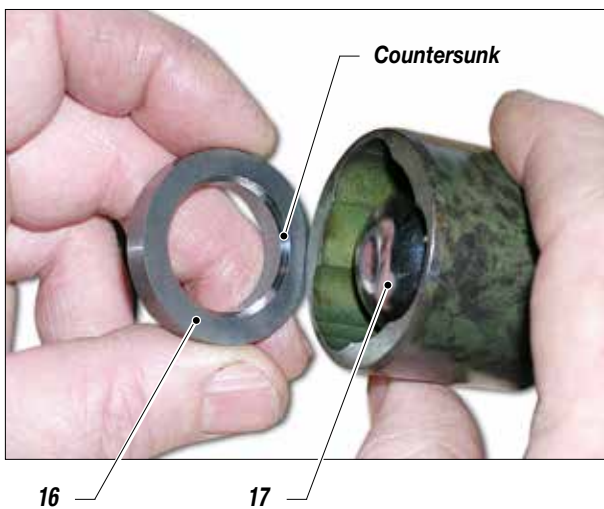

Fig. 23

- Screw the seal ring nut (19) on the pump unit again, without tightening it;

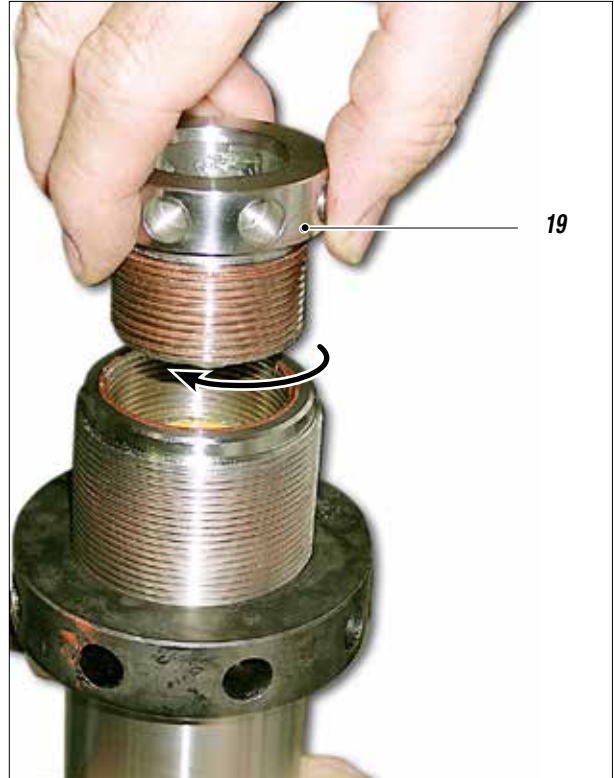

Fig. 24

- Remove the sleeve/cylinder seal (28) and replace it with a new one;



Fig. 25

- Grease the sleeve (29) using a paintbrush;



Fig. 26

- Insert the sleeve (29) into the lower pump unit (30);

⚠ The pumping sleeve is countersunk (31) at one end, simply to facilitate connecting with the stem gaskets.
 Be careful to apply the correct assembly sequence (see exploded diagram).

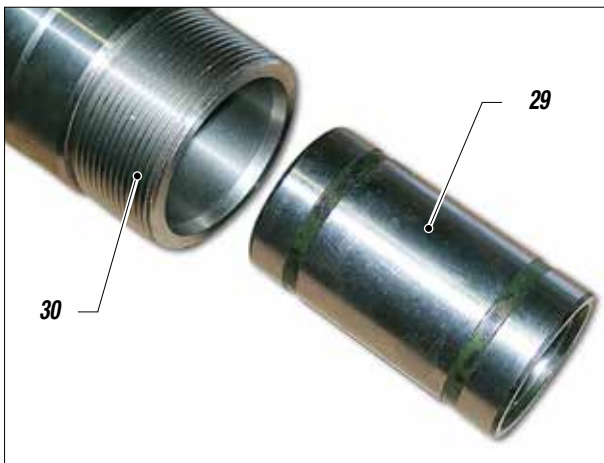

Fig. 27

- Insert the complete piston stem (31) after greasing the gaskets (32);

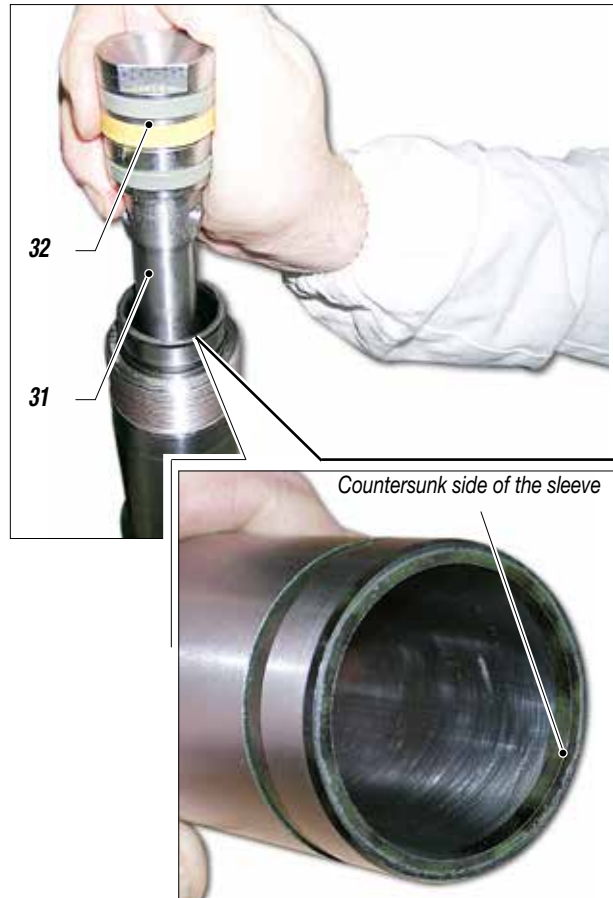

Fig. 28

- Screw on the complete foot valve (25) with the sleeve assembly (28);

⚠ In order to guarantee a proper seal, tighten the foot valve (25) fully, using a 60 mm spanner.

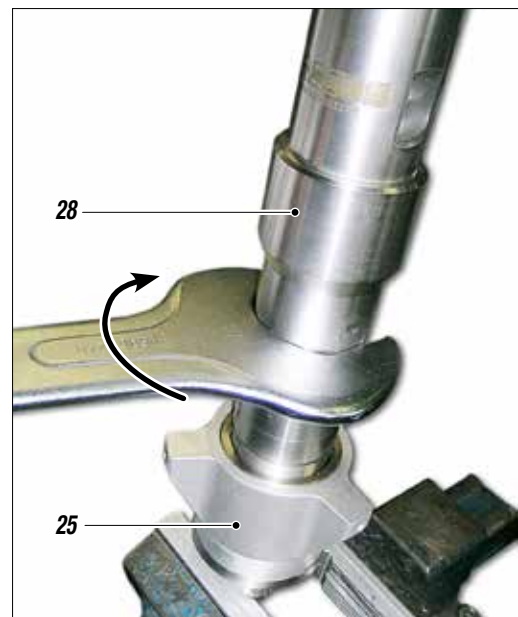

Fig. 29

- When refitting the pump unit on the machine, the stem must be at its highest point possible.
- Insert the stem into the connecting rod and insert the fixing pin (6).

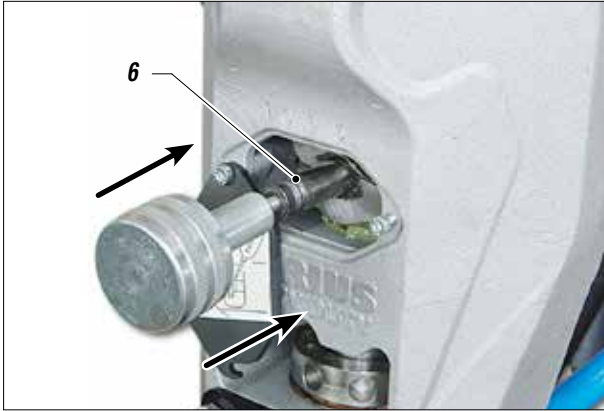

Fig. 30

- Tighten the pump casing all the way and, if the delivery pipe is not correctly aligned, unscrew the pump casing until the connection is in the correct position before tightening by using the ring nut (33) and the pin (34) supplied (ref. 20144).

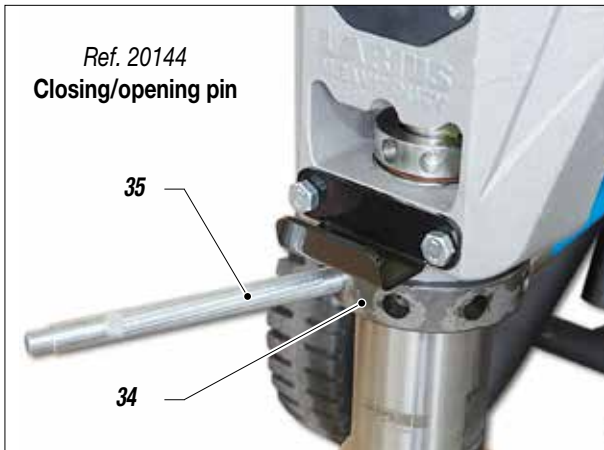

Fig. 31

- Close the seal ring nut (35) all the way.

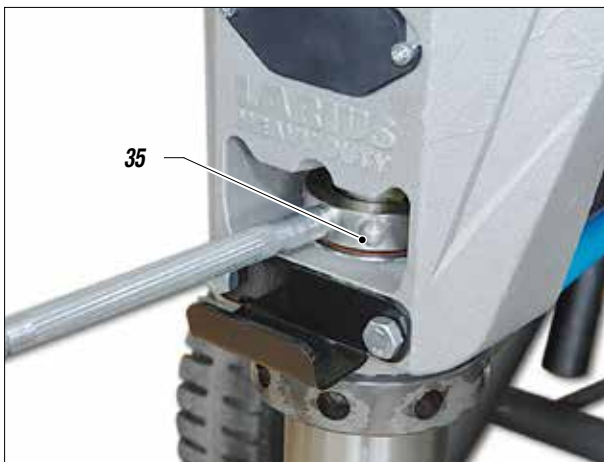

Fig. 32

- Lubricate the upper crown (36) using oil (37) (Ref. 16340);

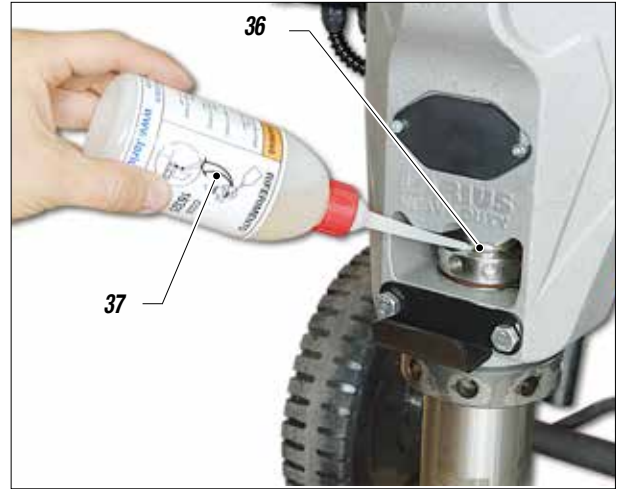

Fig. 33

- Refit the inspection barrier (38);



Fig. 34

- To assemble all the parts in the correct sequence, see the exploded diagram on page 36.

This page is intentionally left blank

SPARE PARTS

Z Electric motor
pag. 60

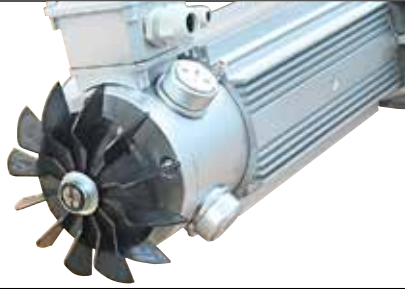

O Complete electro-mechanical unit
pag. 38

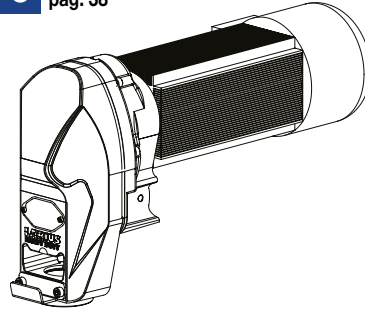

U Pressure control device
pag. 52

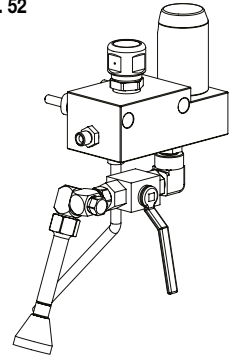

Y Electrical control
pag. 58



W Trolley
pag. 55

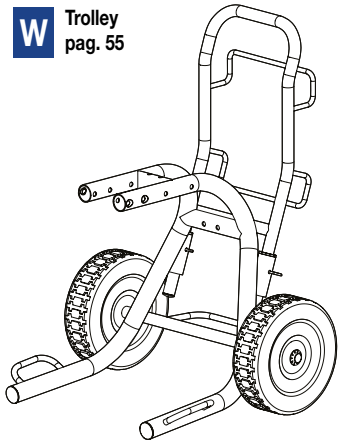

V Suction and circulation unit for standard products
pag. 54



R Short pump unit for standard products
pag. 46

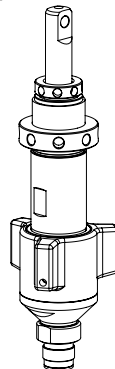

Standard products

Q Complete repair kit and sleeve/piston for long pumping unit
pag. 42

S Spare part kit for short pumping unit
pag. 48

T Filter assembly
pag. 51

X Tank
pag. 56



P Complete long pump unit
pag. 40

Dense products

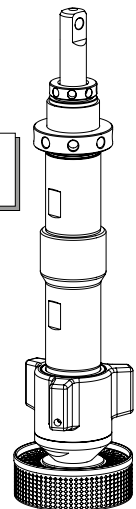

0 COMPLETE ELECTRO-MECHANICAL UNIT

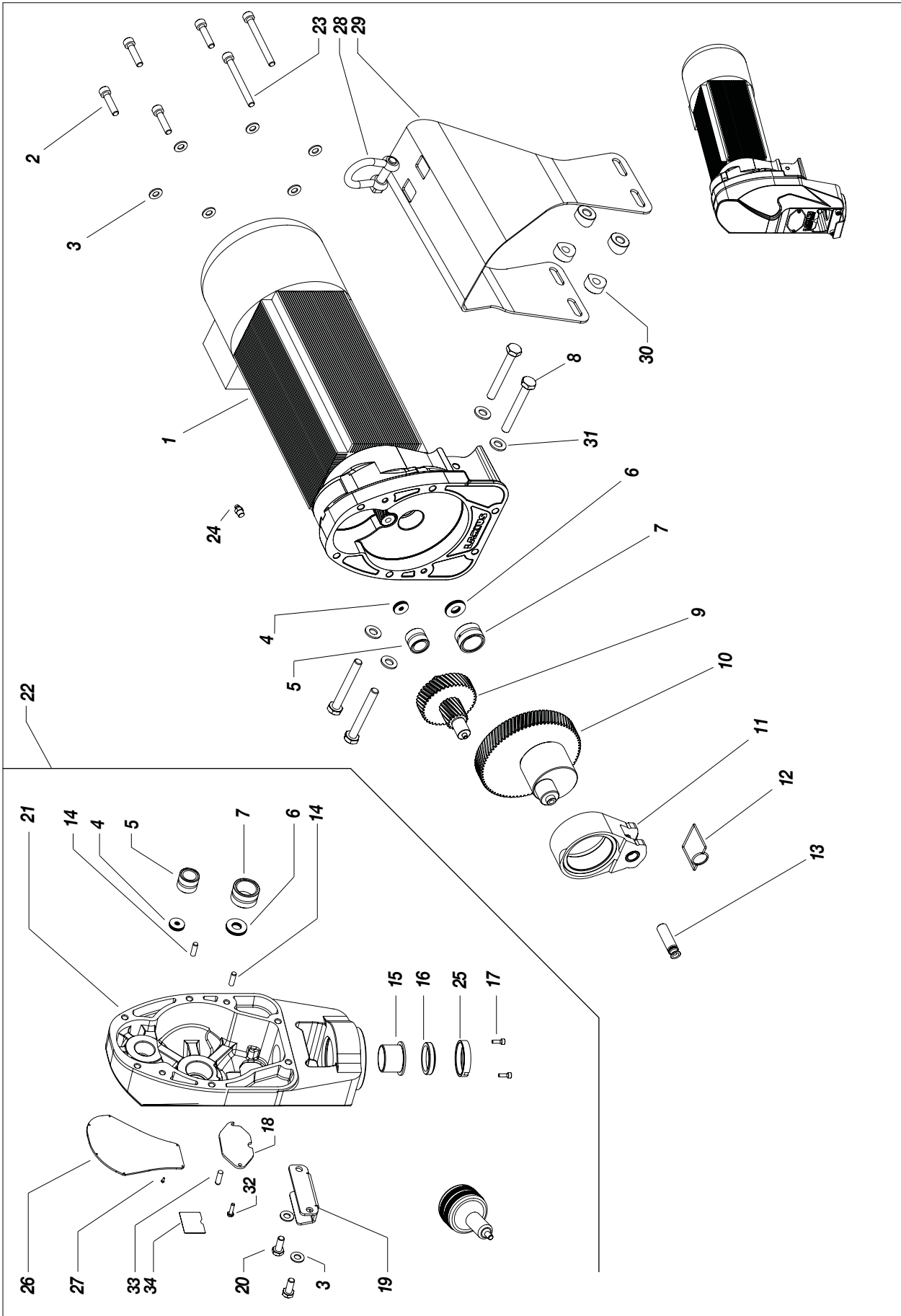

Pos.	Code	Description	Q.ty
1	20241	Electric motor 220V 50Hz	1
2	37177	Screws	4
3	34009	Washer	8
4	20250	Bearing	2
5	20253	Bearing	2
6	20254	Bearing	2
7	20257	Bearing	2
8	69107	Screw M10x80	4
9	20258	Toothed driving assembly	1
10	20259	Cam assembly	1
11	20262	Complete connecting rod	1
12	20263	Positioning spring	1
13	20210	Pump unit pivot	1
14	20264	Centring pin	2
15	20265	Guide bushing	1
16	20266	Scraper	1
17	5378	Screw	2
18	20211	Inspection hatch	1
19	20212	Tin plate door	1
20	69011	Screw	2
21	20202	Reduction unit cover	1
22	20267	Cover assembly	1
23	20268	Screw	2
24	20270	Greasing unit	1
25	20214	Fixing ring	1
26	20215	Front sticker	1
27	34020	Rivet	6
28	20272	Shackle with square head core	1
29	20216	Plating guard	1
30	20514	Spacer bushing	4
31	81033	Flat 10 washer	4
32	20245	Screw M4x10	1
33	20278	Pin	1
34	30274	Warning label	1

P COMPLETE LONG PUMPING UNIT

WARNING: Always indicate code and quantity for each part required.

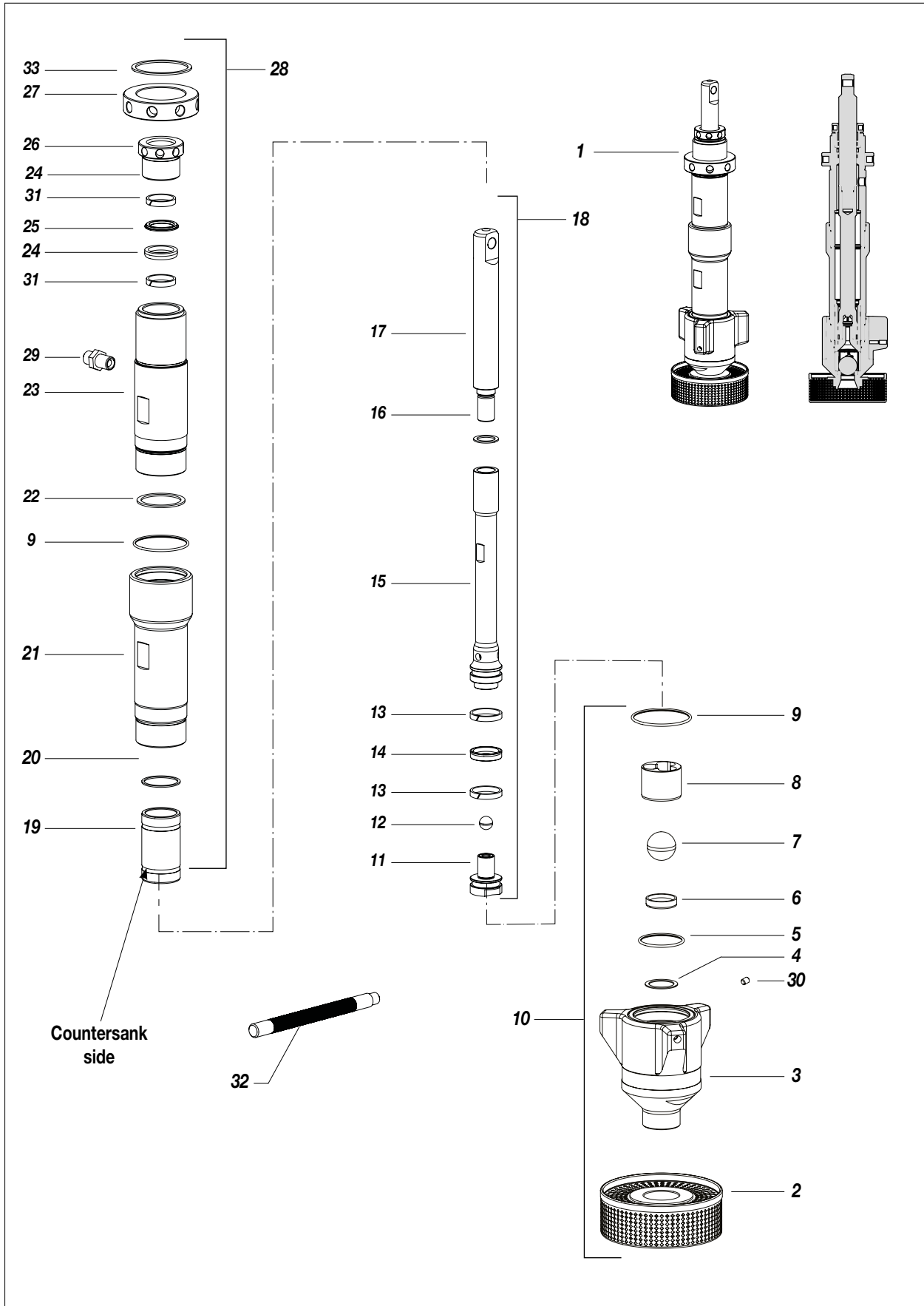

Pos.	Code	Descrpcion	Q.ty
1	20100	Complete long pump unit for heavy products	1
2	20101	Suction filter	1
3	20130	Assembled valve	1
4	19296	Seal	1
5	20131	O-ring	1
6	95029/1	Ball seat	1
7	20149	Closing ball	1
8	19273	Ball guide	1
9	20132	O-ring	2
10	20133	Foot valve assembly for heavy products	1
	20145	Foot valve assembly for standard products	1
11	20134	Stem valve assembly	1
12	16120	Ball	1
13	20135	Lower seal bands	2
14	20136	Lower gasket	1
15	20105	Lower stem	1
16	20106	Seal	1
17	20107	Upper stem	1
18	20137	Stem assembly, heavy products	1
	20146	Stem assembly, standard products	1
19	20108	Sleeve	1
20	20109	Sleeve-cylinder seal	1
21	20110	Lower pump unit casing	1
22	20111	Seal	1
23	20112	Upper pump unit casing	1
24	20138	Upper guide band	2
25	20139	Upper gasket	1
26	20113	Sealing ring nut	1
27	20114	Tightening ring nut	1
28	20140	Sleeve assembly, heavy products	1
	20147	Sleeve assembly, standard products	1
29	95230/1	Niplo	1
30	81009	Dowel	3
31	20122	O-Ring	1
32	20144	Pin	1
33	20285	O-ring	1

Q SPARE KIT FOR LONG PUMPING UNIT

Q.1 COMPLETE REPAIR KIT LONG PUMPING UNIT (COD. 40109)
SLEEVE KIT PLUS PISTON LONG PUMPING UNIT (COD. 20174)

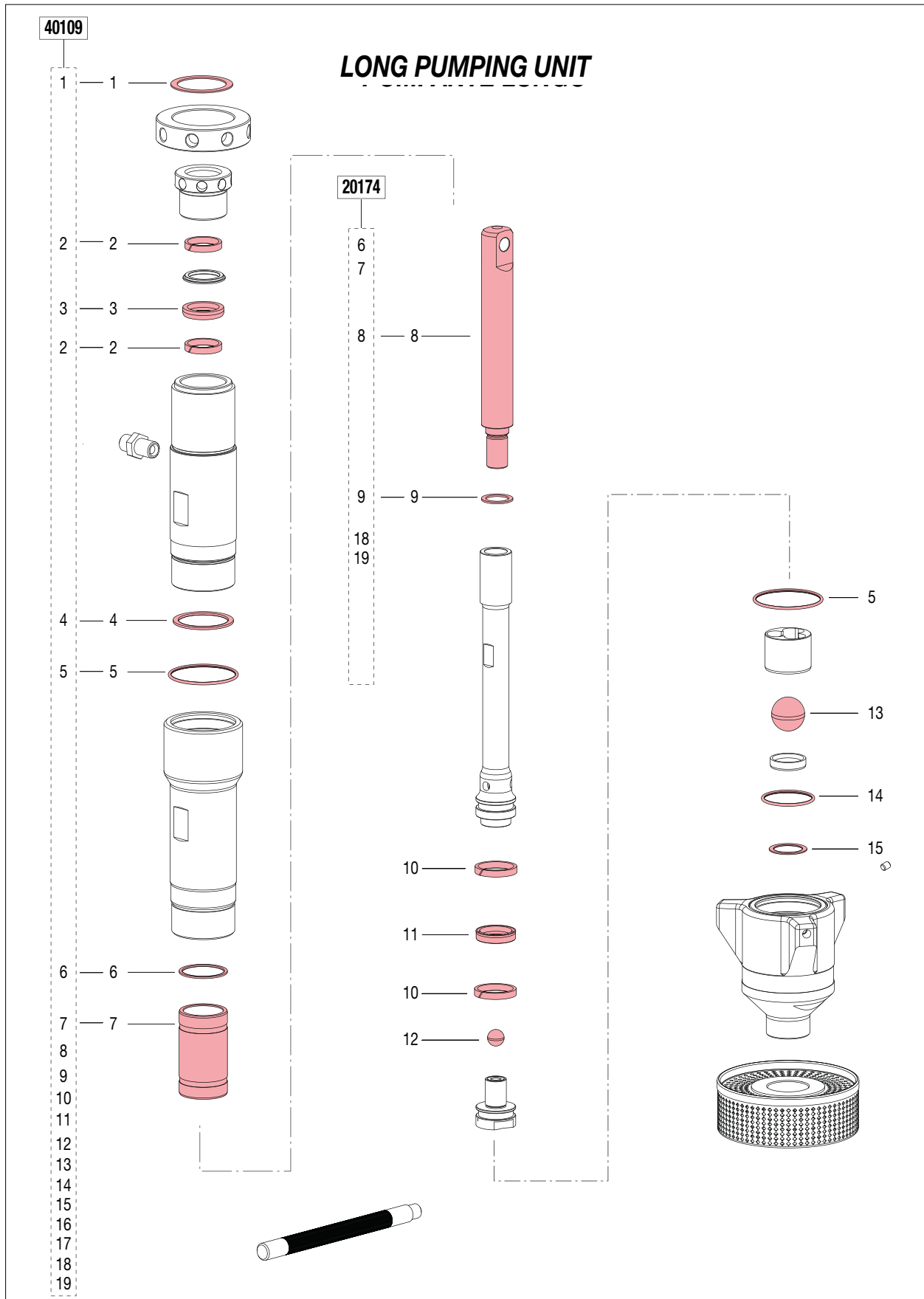

ELECTRO-MECHANICAL UNIT

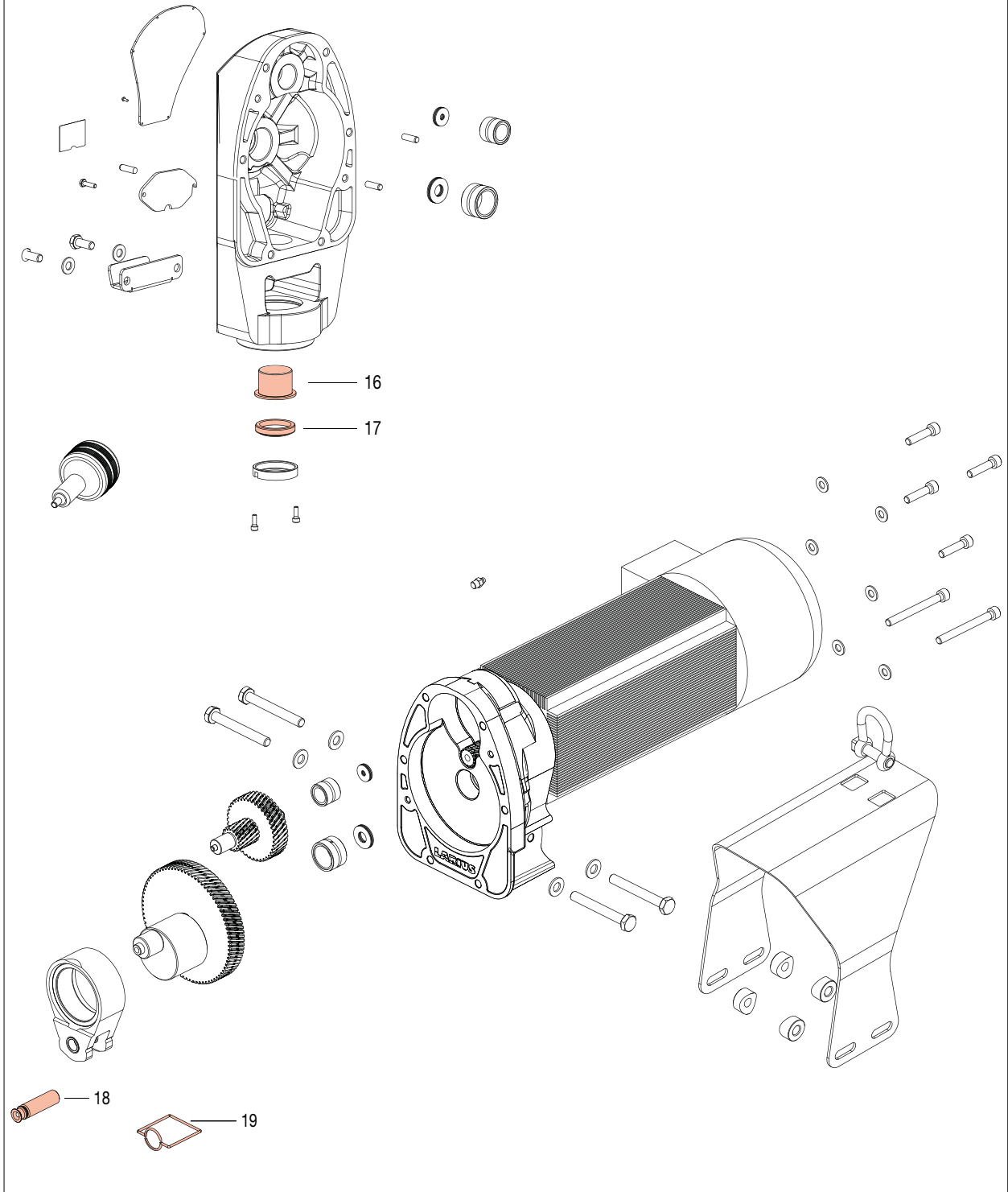

Kit code	Position	Description
40109	1, 2x (2), 3, 4, 2x(5), 6, 7, 8, 9, 2x (10), 11, 12, 13, 14, 15, 16, 17, 18, 19	Complete repair kit for long pumping unit
20174	6, 7, 8, 9, 18, 19	Sleeve-kit plus piston long pumping unit

Q.2 GASKET KIT FOR LONG PUMP UNIT

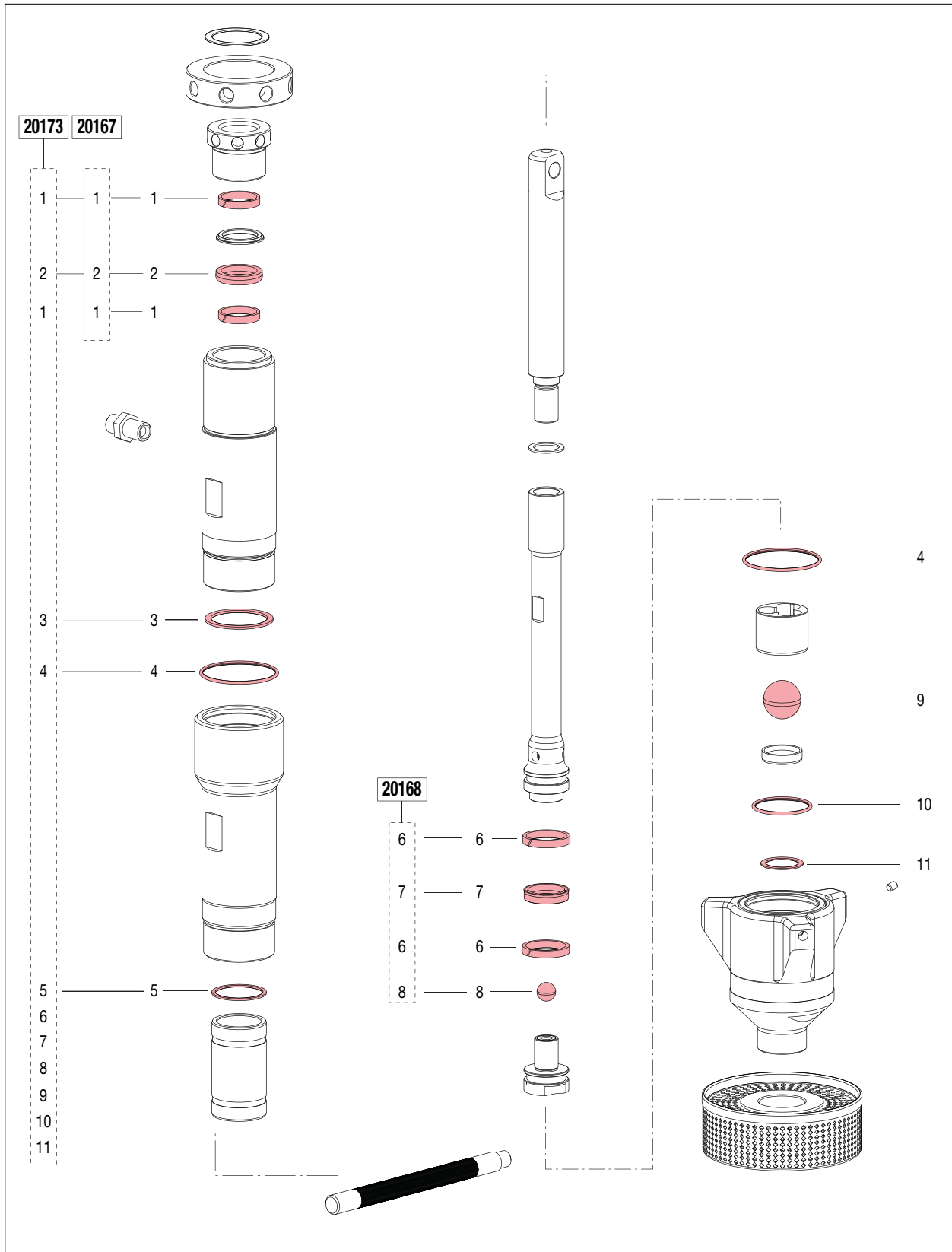

Kit code	Position	Description
20173	2x (1), 2, 3, 2x(4), 5, 2x (6), 7, 8, 9, 10, 11	Complete gasket kit for long pumping unit
20167	2x (1), 2	Upper gasket kit for long pumping unit
20168	2x (6), 7, 8	Lower gasket kit for long pumping unit

This page is intentionally left blank

R SHORT PUMPING UNIT FOR STANDARD PRODUCTS

WARNING: Always indicate code and quantity for each part required.

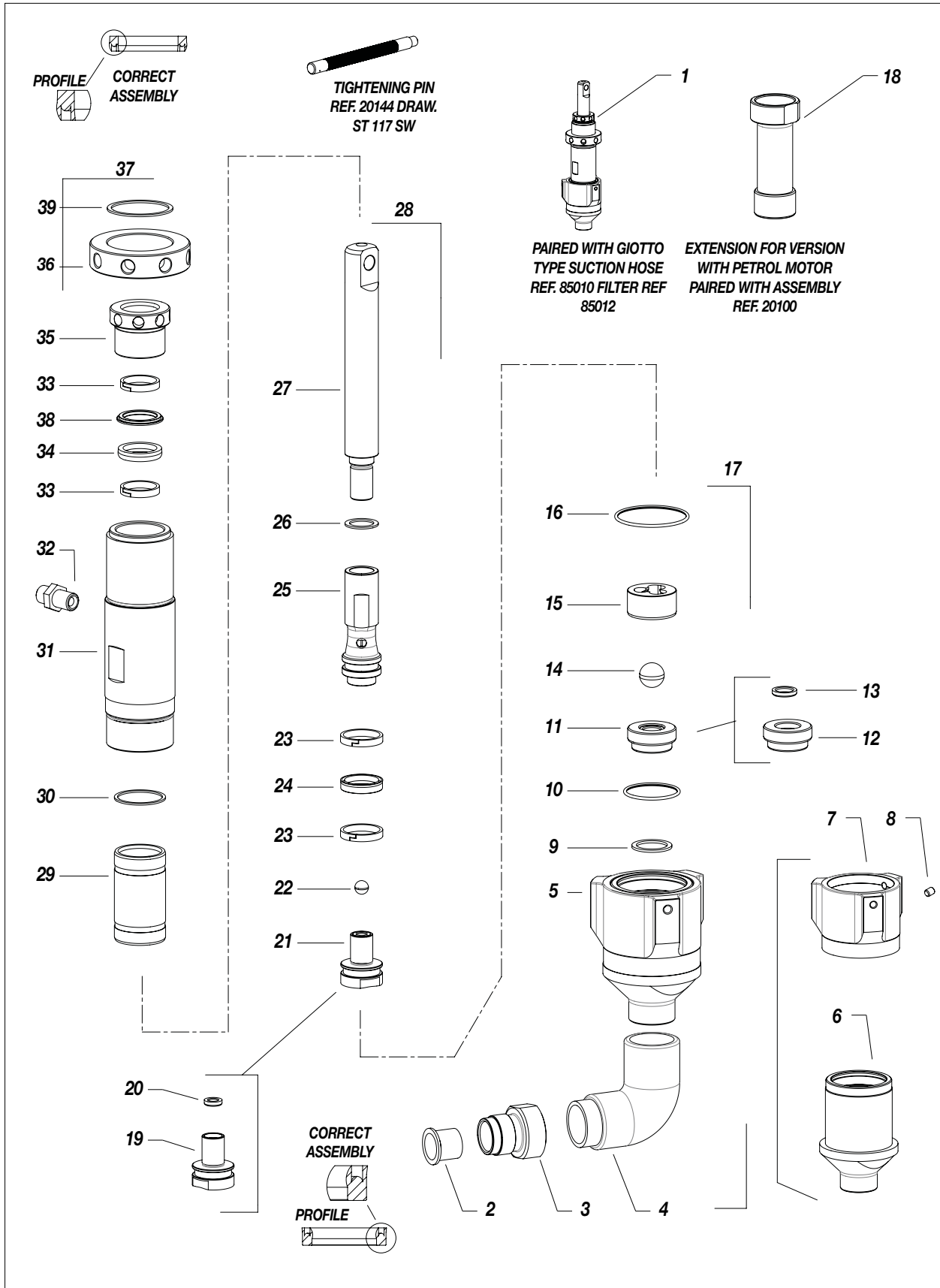

Pos.	Code	Description	Q.ty
1	20142	Complete short pumping unit	1
2	96099	Seal liner	1
3	19295	Dip fitting	1
4	20172	Union 90°	1
5	20130	Assembled valve	1
6	20102	Foot valve body	1
7	20103	Tightening ring nut	1
8	81009	Dowel	1
9	19296	Seal	1
10	20131	O-ring	1
11	20143	Ball housing assembly	1
12	19298	Seat for ball housing	1
13	95023/1	Ball seat	1
14	20148	Ball	1
15	19297	Ball guide	1
16	20132	O-ring	1
17	20145	Foot valve assembly	1
18	20115	Extension	1
19	20104	Stem foot valve	1
20	91018	Ball seat	1
21	20134	Stem valve assembly	1
22	16120	Ball	1
23	20135	Elastic band	2
24	20136	Gasket	1
25	20116	Short stem	1
26	20106	Seal	1
27	20107	Piston stem	1
28	20146	Short stem assembly	1
29	20108	Sleeve	1
30	20109	Seal	1
31	20112	Pumping unit body	1
32	95230/1	Niplo	1
33	20138	Guide ring	2
34	20139	Upper seal	1
35	20113	Sealing ring nut	1
36	20114	Tightening ring nut	1
37	20147	Sleeve assembly	1
38	20122	Ring	1
39	20285	Ring	1

S SPARE KIT FOR SHORT PUMPING UNIT

S.1 COMPLETE REPAIR KIT SHORT PUMPING UNIT (COD. 40109/1)
SLEEVE KIT PLUS PISTON SHORT PUMPING UNIT (COD. 20174)

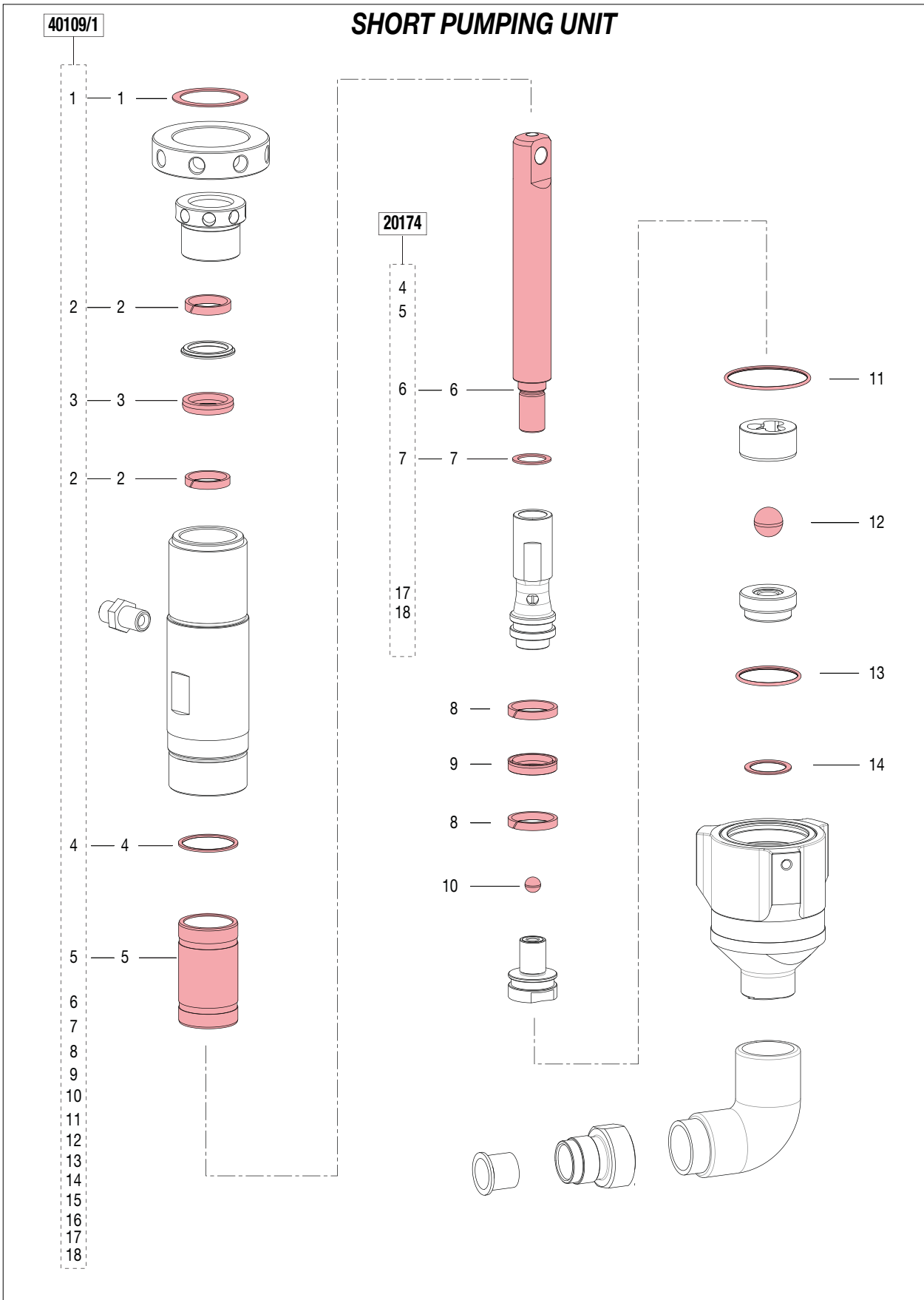

ELECTRO-MECHANICAL UNIT

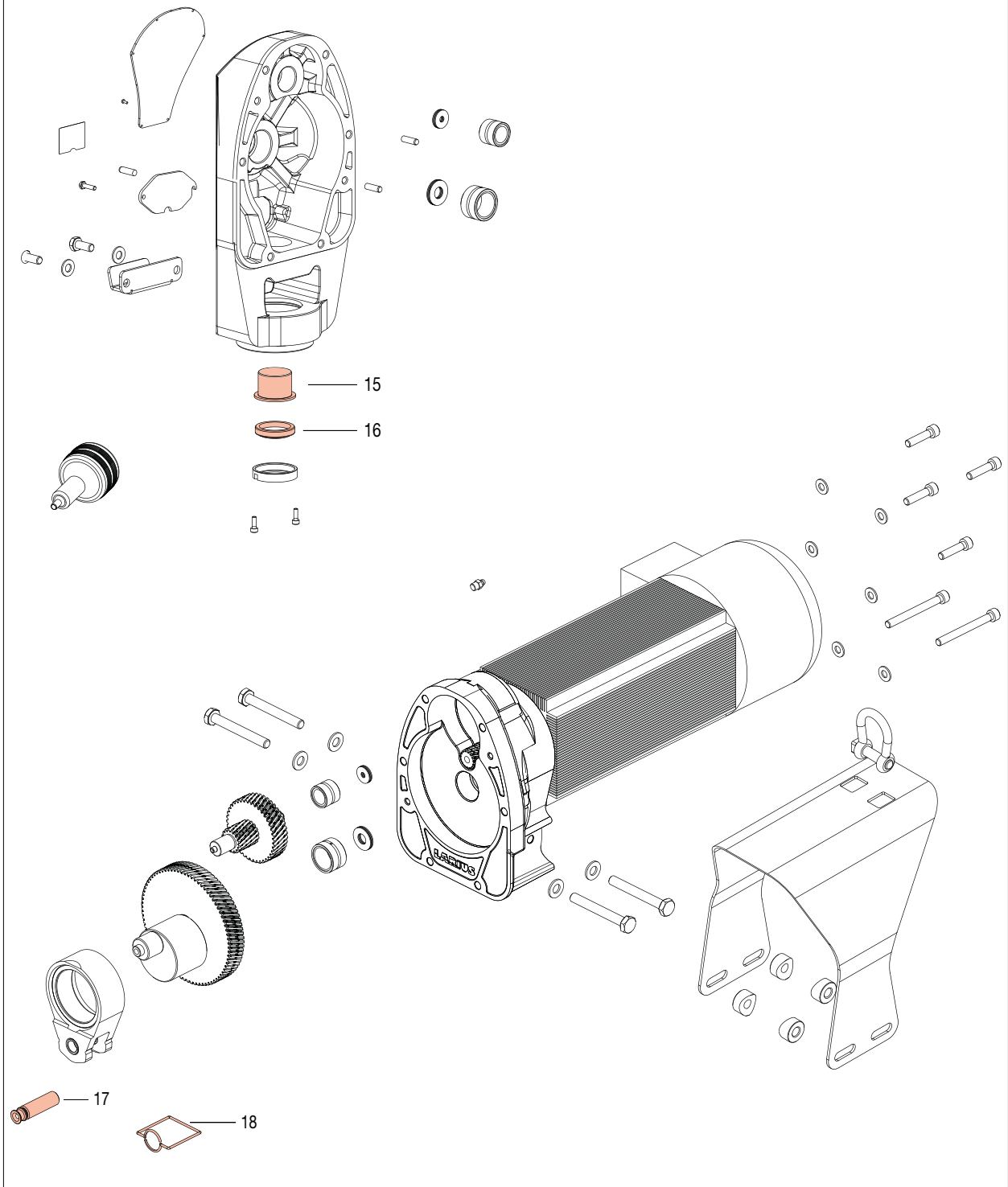

Kit code	Position	Description
40109/1	1, 2x (2), 3, 4, 5, 6, 7, 2x (8), 9, 10, 11, 12, 13, 14, 15, 16, 17, 18	Complete repair kit for short pumping unit
20174	4, 5, 6, 7, 17, 18	Sleeve-kit plus piston short pumping unit

GASKET KIT FOR SHORT PUMPING UNIT

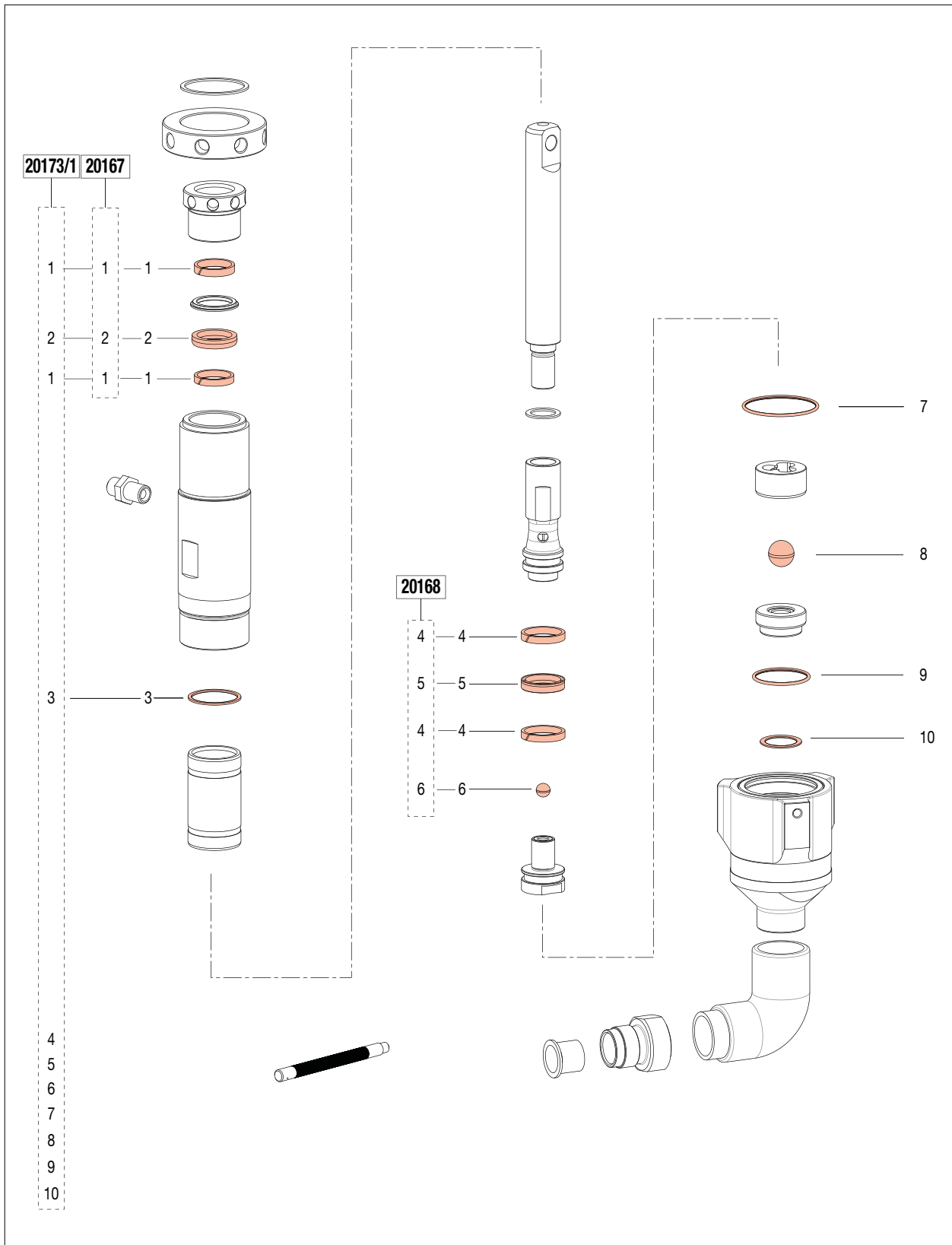

Kit code	Position	Description
20173/1	2x (1), 2, 3, 2x(4), 5, 6, 7, 8, 9, 10	Complete gasket kit for short pumping unit
20167	2x (1), 2	Upper gasket kit for short pumping unit
20168	2x (4), 5, 6	Lower gasket kit for short pumping unit

T FILTER ASSEMBLY: code 37410

WARNING: Always indicate code and quantity for each part required.

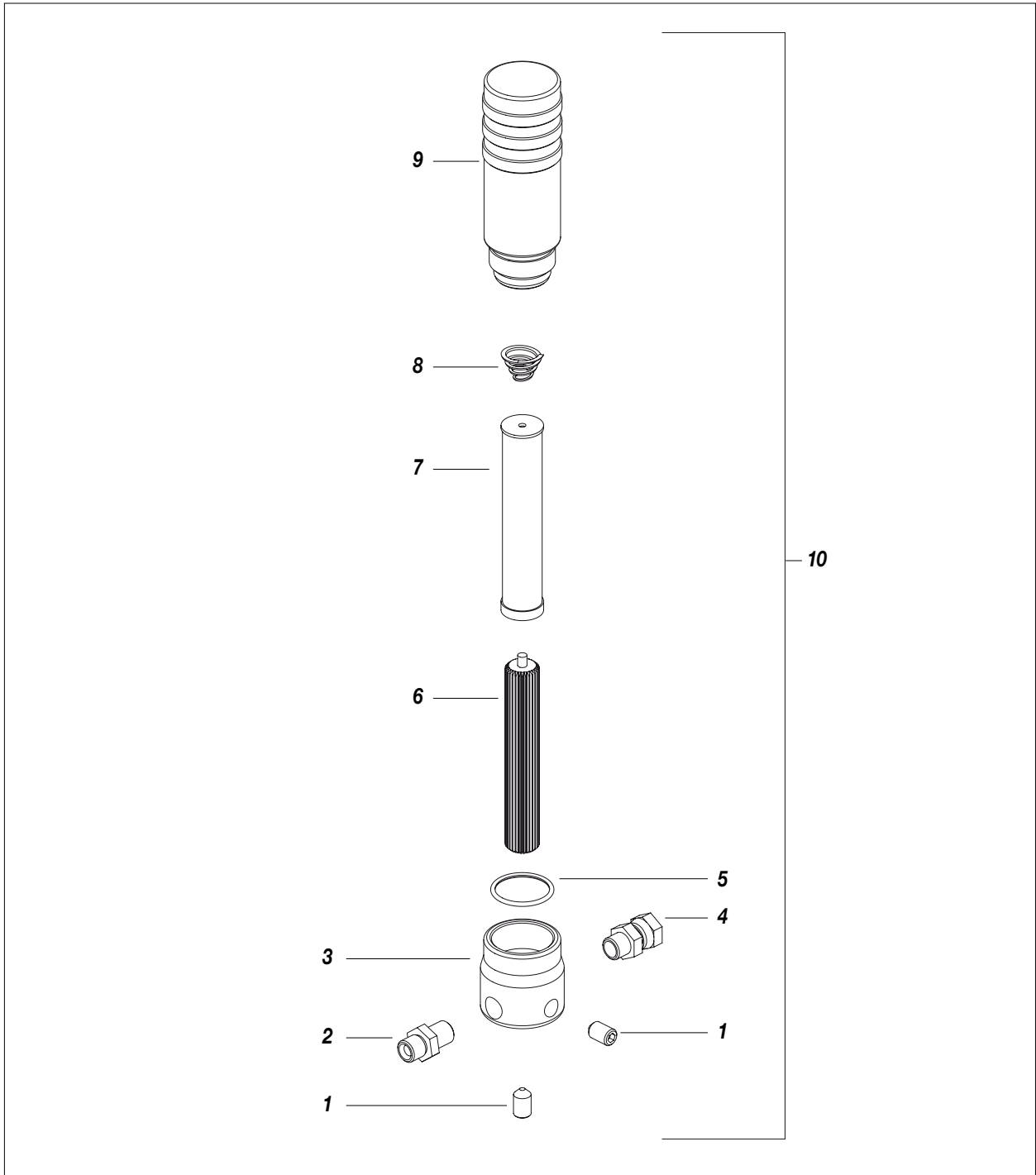

Pos.	Code	Description	Q.ty	Pos.	Code	Description	Q.ty
1	96205	Dowel Gc 1/4 x 10	2	6	96207	Sieve holder	1
2	96206	Nipple M-M 1/4" - M16 x 1.5	1	7	95218	Filter sieve	1
3	96204	Filter base	1	8	96202	Sieve spring	1
4	37453	Nose union	2	9	96201	Filter tank	1
5	96203	O-r	1	10	37410	Filter assembly	1

U PRESSURE CONTROL DEVICE



The Manufacturer declines all responsibility for any damage or malfunction of the machine following tampering or alteration of the valve calibration.

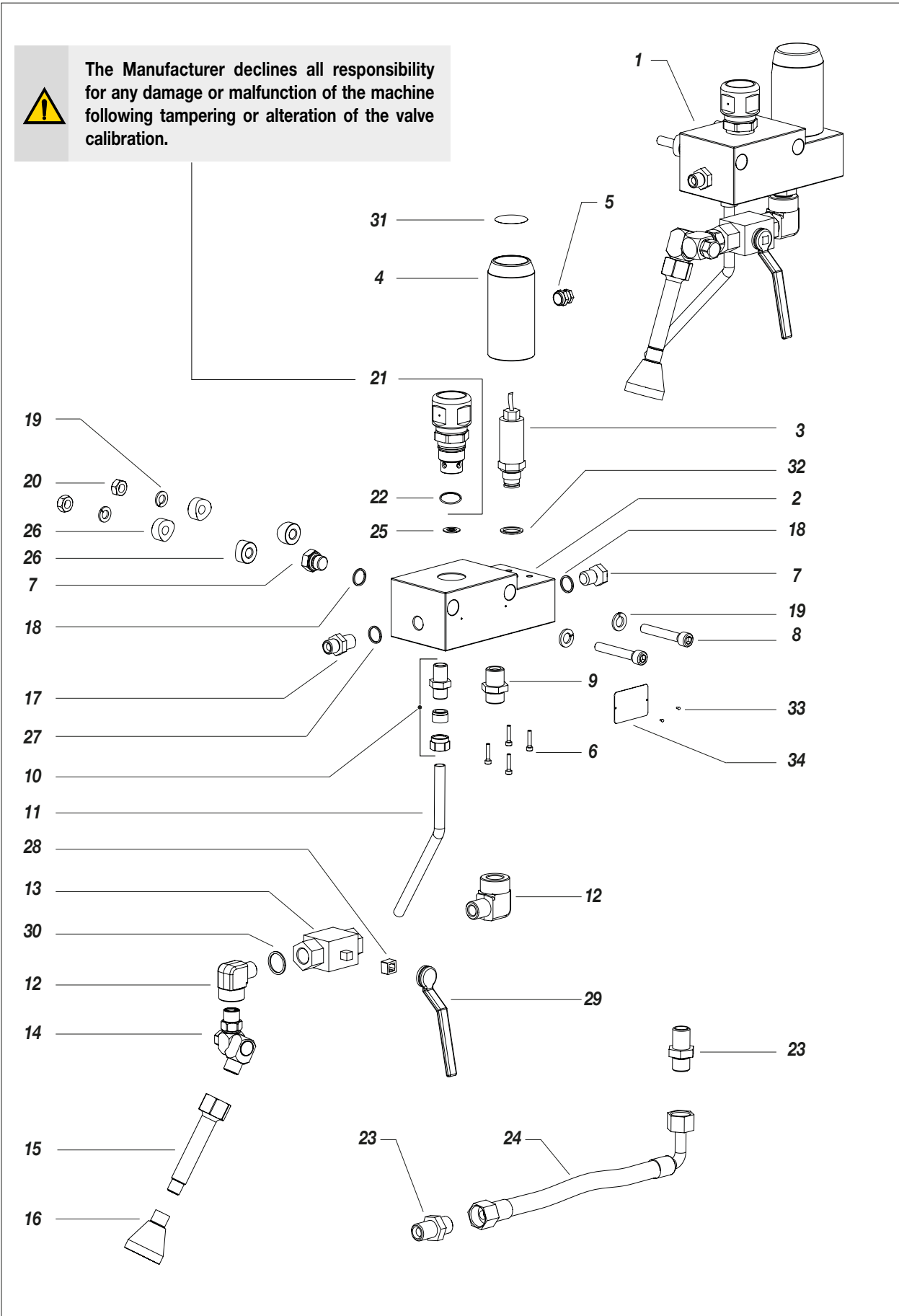

Pos.	Code	Description	Q.ty
1	20400	Complete unit	1
2	20401	Control stop	1
3	20457	Digital pressure switch	1
4	20402	Protection	1
5	20450	Cable fastener	1
6	20436	Screw	4
7	20452	3/8 GJ cap with a.p. hexagonal head	1
8	20430	Screw	2
9	96255	Union AP	1
10	20460	Locking connection	1
11	20418	Safety discharge pipe	1
12	20451	Elbow AP	1
13	33035	Tap AP FF 1/2" lower ball	2
14	20403	Elbow assembly	1
15	20412	Discharge pipe	1
16	18350	Dispersion bell assembly	1
17	33006	Material outlet pipe fitting	1
18	33010	Seal	2
19	33005	Washer	6
20	95158	Nut	2
21	20423	Complete safety valve assembly	1
22	3645	O-ring	1
23	34109	Adapter	1
24	20455	Delivery pipe assembly	1
25	33026	Gasket	2
26	20514	Bush	1
27	33007	Seal	1
28	20419	Spacer ring	1
29	20445	3/4" lever	2
30	8071	Seal	1
31	30439	Warning label	1
32	20421	Sealing ring	1
33	34020	Rivet ø 2,5	2
34	20175	Technical data label	1

V SUCTION AND CIRCULATION UNIT FOR STANDARD PRODUCTS

WARNING: Always indicate code and quantity for each part required.

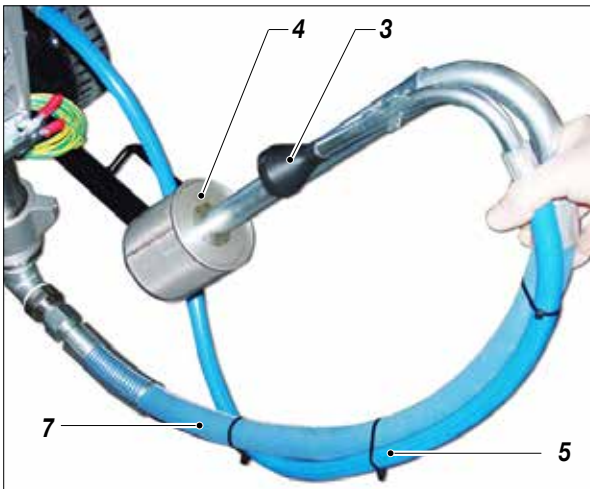
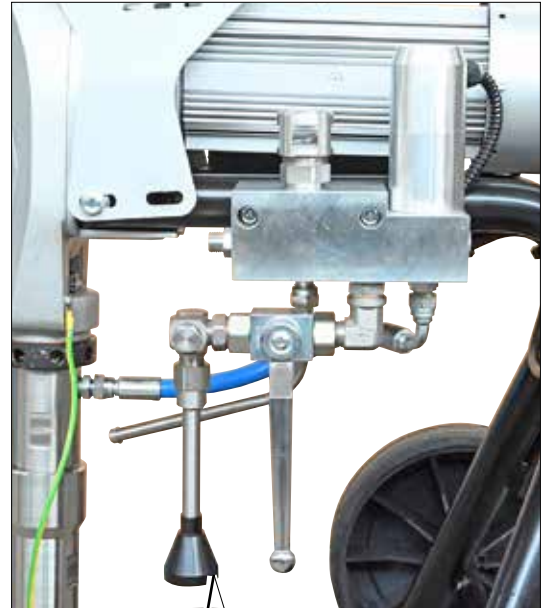
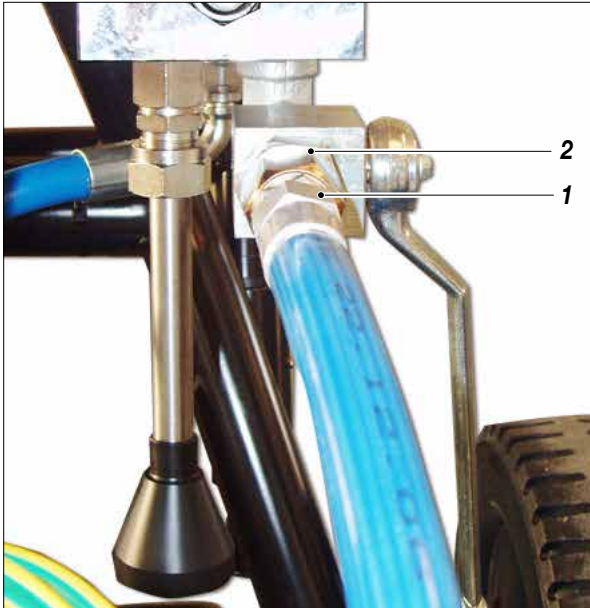

Pos.	Code	Description	Q.ty
1	3373	Reduction	1
2	3387	Union	1
3	18350	Dispersion bell	1
4	85012	Filter	1
5	20557	Recirculation tube	1
6	20555	Safety tube	1
7	20556	Suction tube	1

Pos.	Code	Description	Q.ty
-	20550	Recirculation tube+Safety tube+Suction tube	1+1+1
8	18377	Reduction	1
9	18378	Swivel connection	1
10	18353	Tube	1
11	18352	Scattering layer	1
12	18351	Bell	1

W CARRIAGE

WARNING: Always indicate code and quantity for each part required.

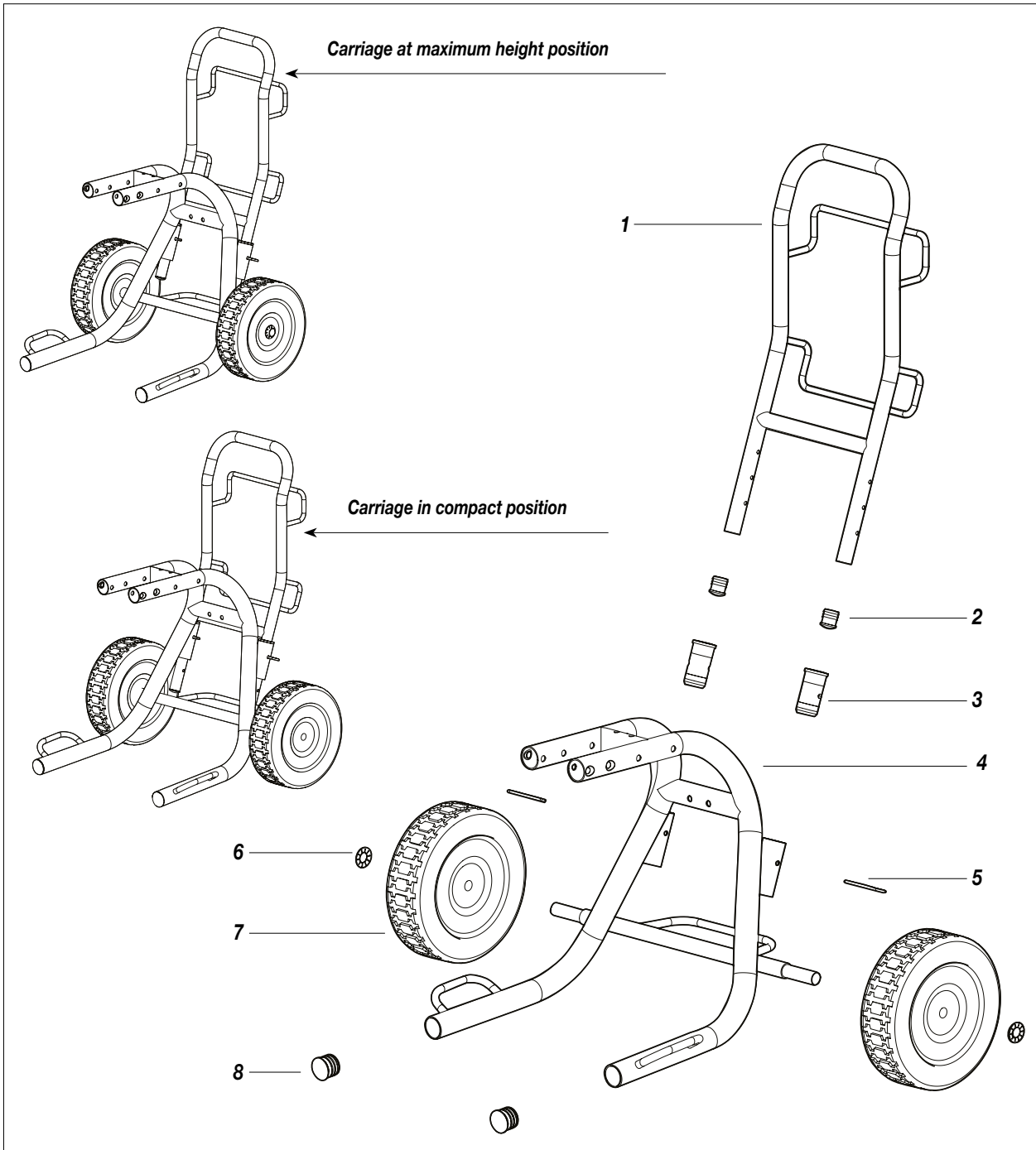

Pos.	Code	Description	Q.ty
-	20300	Complete carriage	-
1	20301	Carrying handle	1
2	95159	Pipe cap	2
3	18914	Bushing	2
4	20302	Carriage	1

Pos.	Code	Description	Q.ty
5	18902	Split pin	2
6	20305	Wheel stop washer	2
7	20303	Wheel Ø300 mm	2
8	20304	Pipe cap	2

X TANK

WARNING: Always indicate code and quantity for each part required.

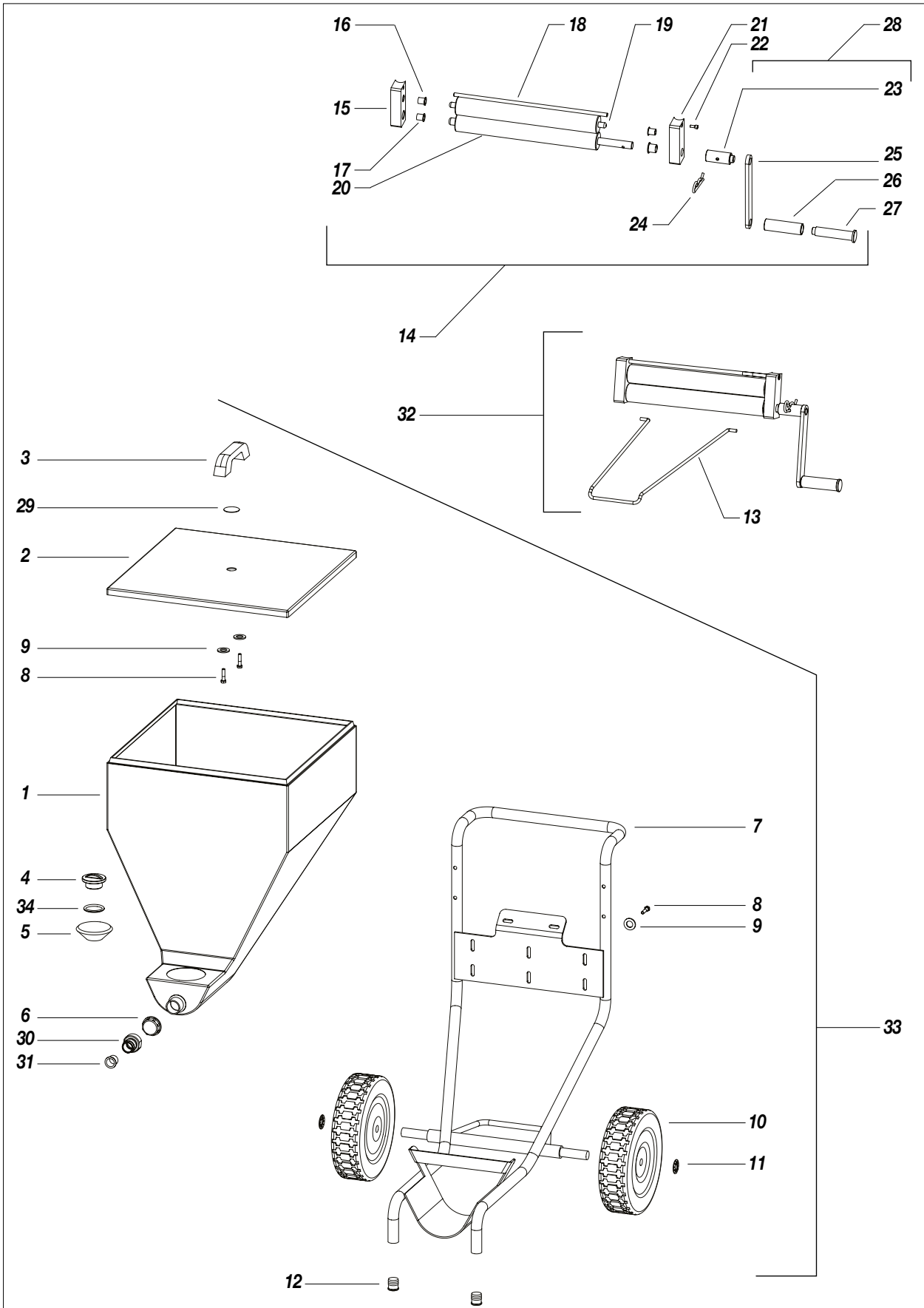

Pos.	Code	Description	Q.ty
1	20326	Tank	1
2	20329	Cover	1
3	20320	Carrying handle	1
4	20321	Male plug	1
5	20330	Gasket	1
6	20322	Female plug	1
7	20327	Trolley	1
8	8385	Screw	8
9	34009	Washer	8
10	20303	Wheel	2
11	20305	Wheel stop washer	2
12	37403	Cap	2
13	20328	Bag support bar	1
14	20325	Bag pressing assembly	1
15	20331	Right shoulder	1
16	18664	Bushing	2
17	20323	Bushing	2
18	20336	Spacer	1
19	20333	Idle roller	1
20	20334	Motor roller	1
21	20332	Left shoulder	1
22	91062	Screw	1
23	20337	Bushing	1
24	21683	Split pin	1
25	20335	Lever	1
26	20339	Bushing	1
27	20338	Crank handle	1
28	20319	Crank handle assembly	1
29	20324	Cover cap	1
30	19295	Union	1
31	96099	Seal	1
32	18244	Package pressing kit	1
33	18243	Complete tank 100Lt	1
34	3468	O-ring	1

Y ELECTRICAL CONTROL

WARNING: Always indicate code and quantity for each part required.

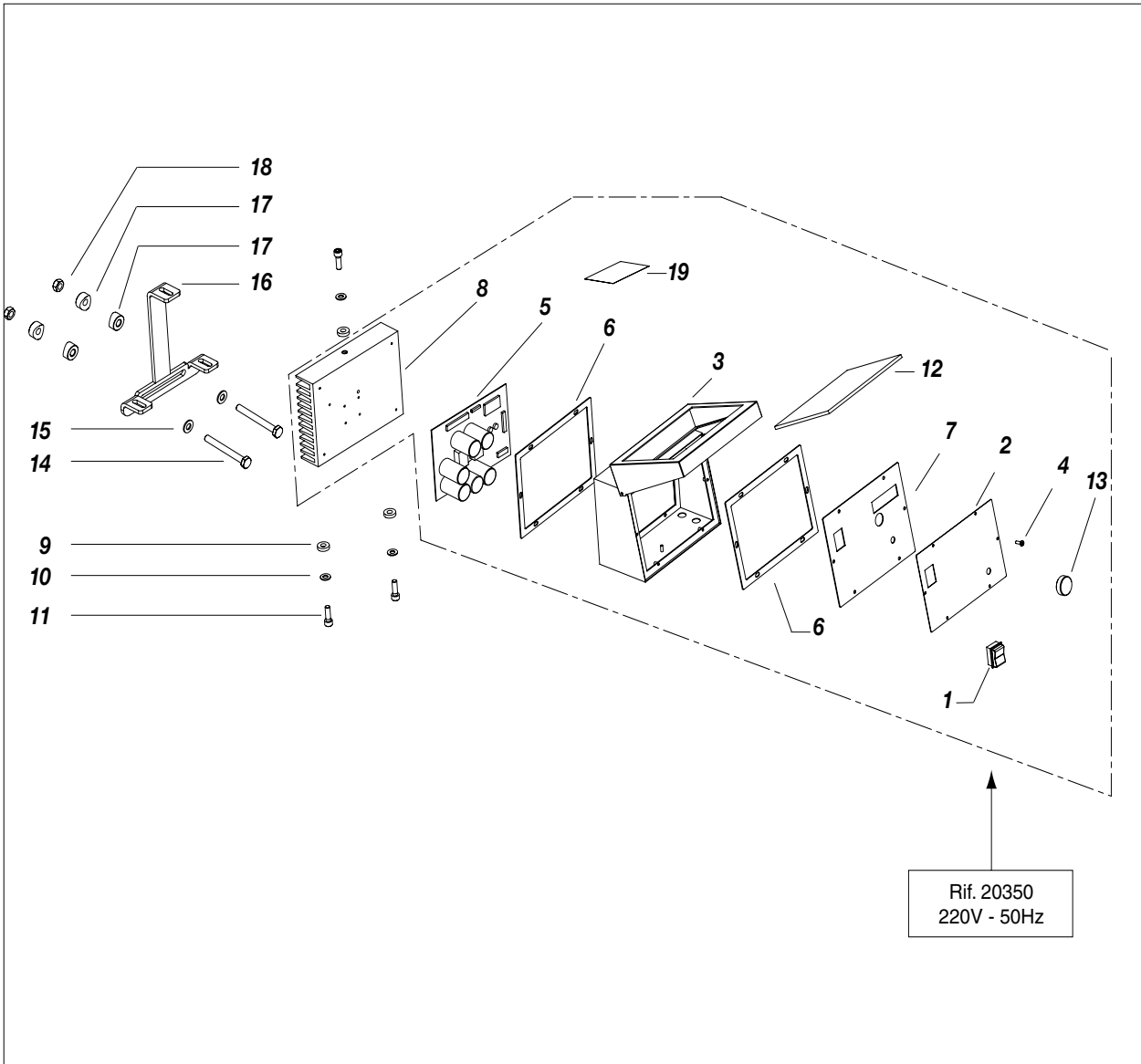

Pos.	Code	Description	Q.ty
-	20350	Complete electronic box	-
1	5933	Switch	1
2	20355	Panel	1
3	20354	Electronic box	1
4	96028	Screw M4x10 UNI 7687	6
5	20365	Electronic board	1
6	18483	Rubber seal	2
7	18493	Tightening sheet	1
8	20352	Dissipator	1
9	8011	Anti-vibration washers	3

Pos.	Code	Description	Q.ty
10	34009	Schorr washer \varnothing 8	3
11	34008	Screw M8x20 UNI 5931	3
12	20340	Transparent sheet	1
13	20349	Knob	1
14	20345	Screw M10x90 UNI 5931	2
15	81033	Schorr washer	2
16	20351	Support plate	1
17	20514	Spacer bushing	4
18	95158	Nut M10 UNI 5588-65	2
19	16850	Warning label	1

Z ELECTRIC MOTOR

WARNING: Always indicate code and quantity for each part required.



DISCONNECT THE POWER SUPPLY BEFORE CHECKING OR REPLACING THE BRUSHES.

- Periodically check on the wear of the pinion (*at least every 1000 working hours*).
- Periodically check the perfect connection among all the electrical components (*at least every 200 working hours*).
- The length of the brush contact must be higher than **9 mm** to guarantee a good working of the rotary group.

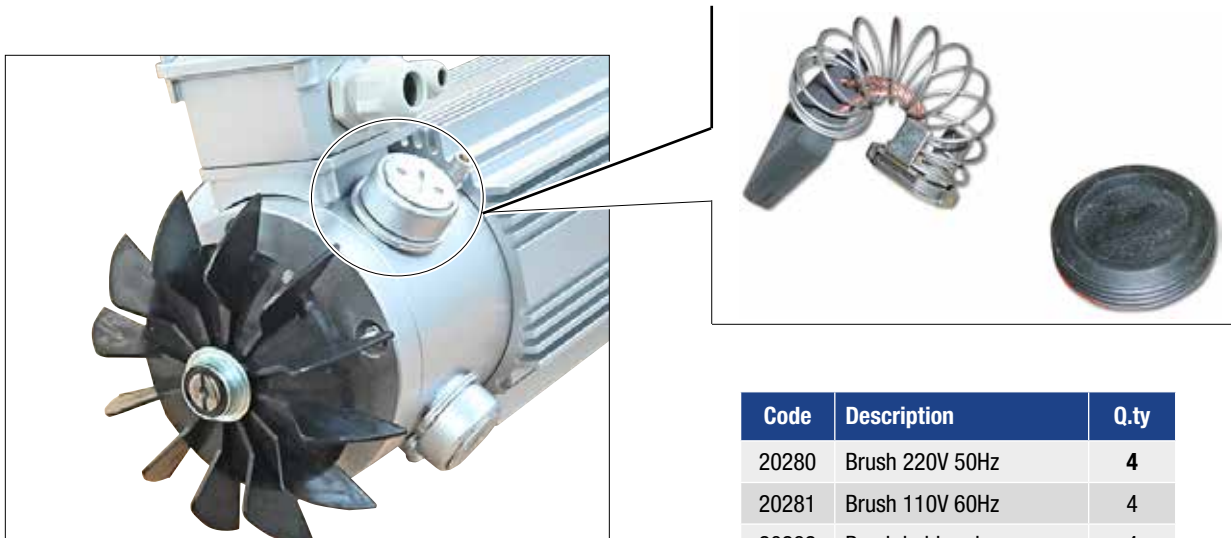

Fig. 1

Code	Description	Q.ty
20280	Brush 220V 50Hz	4
20281	Brush 110V 60Hz	4
20282	Brush holder plug	4

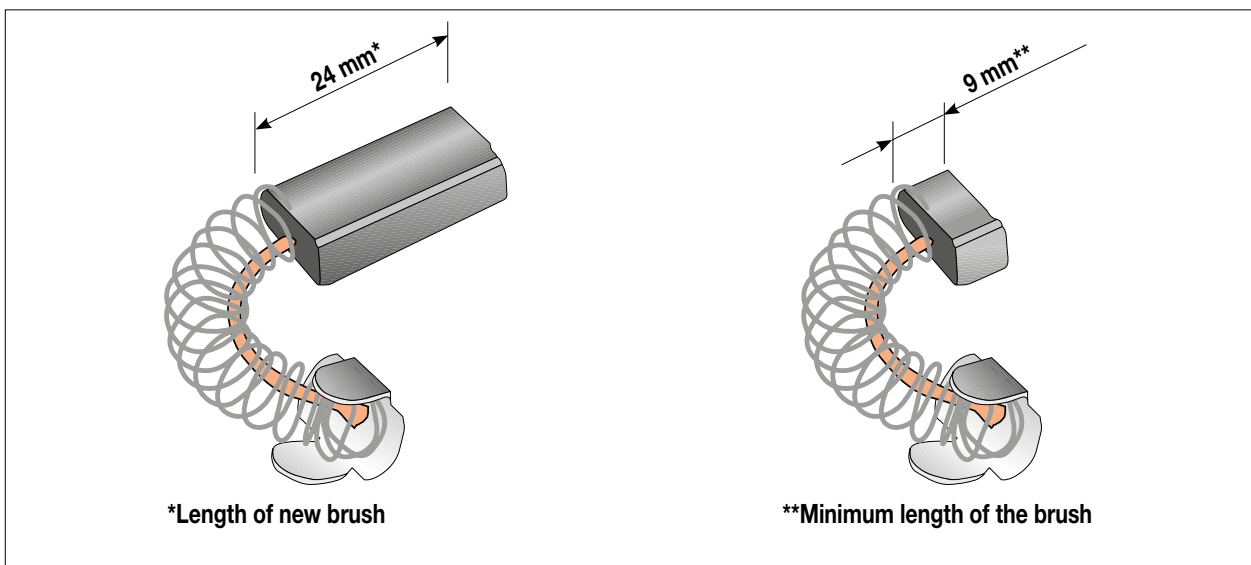

Fig. 2

AA ELECTRICAL DIAGRAM

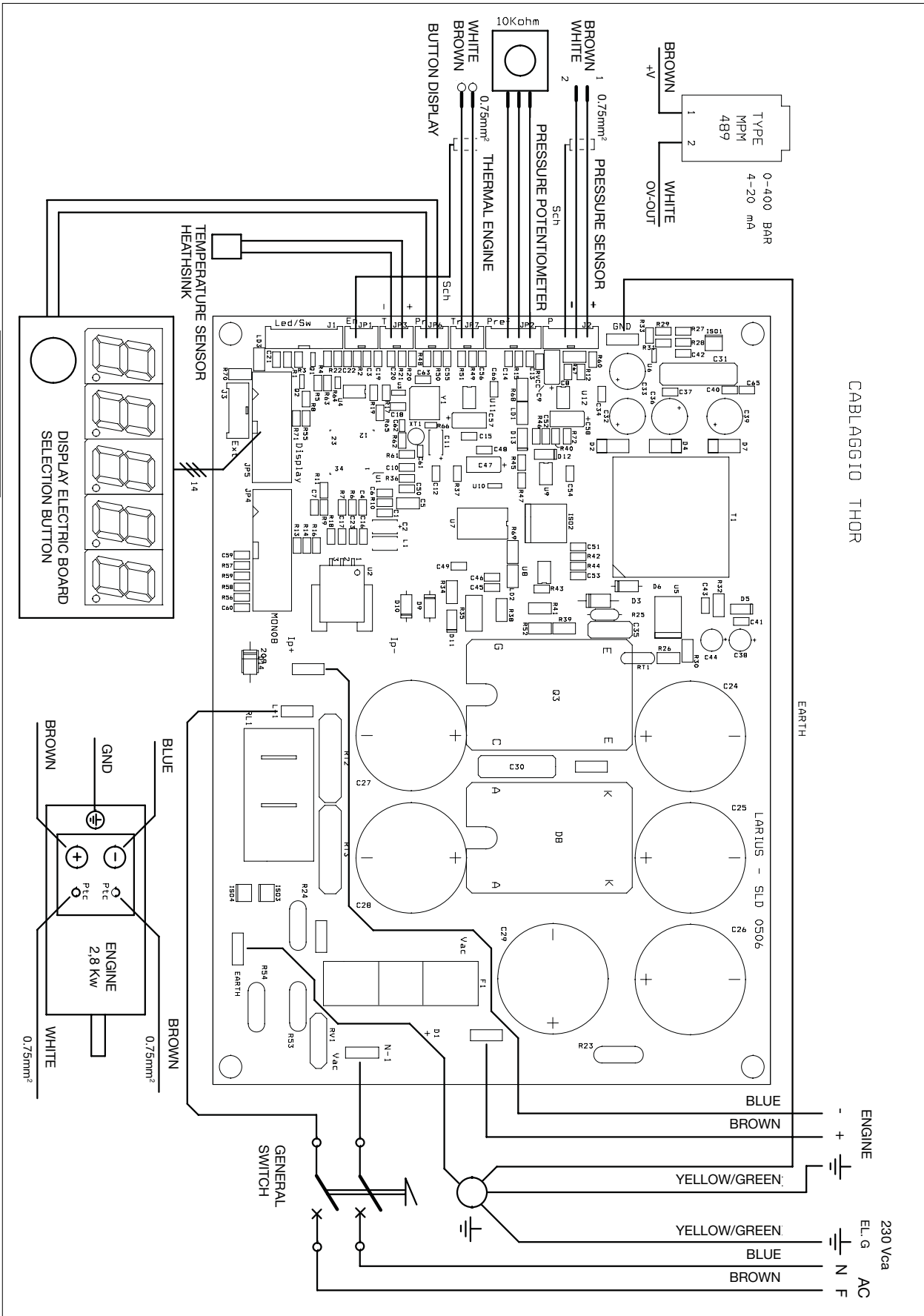

Fig. 1



CE DECLARATION OF CONFORMITY



Company



LARIUS srl
Via Antonio Stoppani 21 - 23801 Calolziocorte (LC) ITALY
Tel: +39 0341 621152
Fax: +39 0341 621243
E-mail: larius@larius.com

Declares under his owns responsibility that the product:

THOR Electric piston pump

complies with the directives:

- EC Directive 2006/42 Machinery Directive
- EU Directive 2014/30 Electromagnetic Compatibility (EMC)
- EU Directive 2014/35 Low Voltage (LVD)

furthermore to the
harmonized standards:

- UNI EN ISO 12100-1/-2
Machinery safety, basic concepts, general principles of design. Basic terminology, methodology. Technical principles.

This declaration relates exclusively to the product in the state in which it was placed on the market, and excludes components or modifications which are added or carried out subsequently by end user.

Signature

Pierangelo Castagna
Managing Director

Calolziocorte, 28 February 2024
Location / Date



SAMOA INDUSTRIAL, S.A. - HEADQUARTERS
SPAIN AND EXPORT MARKETS
 POL. IND. PORCEYO, I-14 - CAMINO DEL FONTÁN, 831
 E-33392 GIJÓN (ASTURIAS), SPAIN
 TEL.: +34 985 381 488 - FAX: + 34 985 147 213

SAMOA S.A.R.L.
FRANCE
 P.A.E.I. DU GIESSEN
 3, RUE DE BRISCHBACH
 67750 SCHERWILLER, FRANCE
 TEL.: +33 3 88 82 79 62 - FAX: +33 3 88 82 77 88

SAMOA ITALIA - LARIUS
ITALY
 VIA ANTONIO STOPPANI,21
 23801 CALOLZIOCORTE (LC) ITALY
 Tel.: +39 0341 621152 - Fax: + 39 0341 621242

SAMOA FLOWTECH GMBH
 GERMANY, AUSTRIA, SWITZERLAND, THE NETHERLANDS AND GREECE
 AM OBEREICHHOLZ 4
 D - 97828 MARKTHEIDENFELD, GERMANY
 TEL.: +49 9391 9826 0 - FAX: +49 9391 98 26 50

SAMOA LTD.
UNITED KINGDOM AND REP. OF IRELAND
 ASTURIAS HOUSE - BARRS FOLD ROAD
 WINGATES INDUSTRIAL PARK
 WESTHOUGHTON, BL5 3XP, UK
 TEL.: +44 1942 850600 - FAX: +44 1942 812160

SAMOA CORPORATION
 USA AND CANADA
 90 MONTICELLO ROAD
 WEAVERVILLE, NC 28787, USA
 TEL. +1 (828) 645-2290 - FAX: +1 (828) 658 0840



©Copyright, SAMOA INDUSTRIAL, S.A.
 SAMOA Industrial, S.A. is an ISO 9001, ISO 14001 and ISO 45001 certified company.

»»» Contact us today!
 Visit www.samoaindustrial.com for more information.

OPERATING AND MAINTENAINCE MANUAL AVAILABLE IN:		
	IT	https://www.larius.com/wp-content/uploads/THOR_I.pdf
	EN	https://www.larius.com/wp-content/uploads/THOR_GB.pdf
	DE	https://www.larius.com/wp-content/uploads/THOR_D.pdf
	FR	https://www.larius.com/wp-content/uploads/THOR_F.pdf
	ES	https://www.larius.com/wp-content/uploads/THOR_E.pdf
	PL	https://www.larius.com/wp-content/uploads/THOR_PL.pdf
	PT	https://www.larius.com/wp-content/uploads/THOR_P.pdf