



www.larius.com

OMEGA 40:1 EXT V2

Airless pneumatic pump
for extrusion



- | | |
|----|---|
| IT | https://www.larius.com/wp-content/uploads/OMEGA_40_1_EXT_I.pdf |
| EN | https://www.larius.com/wp-content/uploads/OMEGA_40_1_EXT_GB.pdf |
| DE | https://www.larius.com/wp-content/uploads/OMEGA_40_1_EXT_DE.pdf |

This manual is to be considered as an English language translation of the original manual in Italian. The manufacturer shall bear no responsibility for any damages or inconveniences that may arise due to the incorrect translation of the instructions contained within the original manual in Italian.

Due to a constant product improvement programme, the factory reserves the right to modify technical details mentioned in this manual without prior notice.

OMEGA 40:1 EXT V2

Airless pneumatic pump for extrusion

INDEX



















A	WARNINGS	2
B	WORKING PRINCIPLE	3
C	TECHNICAL DATA	4
D	DESCRIPTION OF THE EQUIPMENT	5
E	TRANSPORT AND UNPACKING	6
F	SAFETY RULES.....	6
G	CONDITIONS OF GUARANTEE	7
H	TYPICAL INSTALLATION.....	8
I	SETTING UP.....	8
J	WORKING	8
K	CLEANING AT THE END OF THE WORK	9
L	ROUTINE MAINTENANCE	9
M	TROUBLESHOOTING	10
N	DISASSEMBLY OF THE PNEUMATIC MOTOR.....	11
O	DISASSEMBLY OF THE PUMPING GROUP	16
P	EXPLODED VIEW FOR PUMPING GROUP	18
Q	EXPLODED VIEW FOR MOTOR GROUP RIF. 7105	20
R	ATEX CERTIFICATION	22
	DECLARATION OF CONFORMITY.....	25

**WE ADVISE THE USE OF THIS EQUIPMENT ONLY BY PROFESSIONAL OPERATORS.
 ONLY USE THIS MACHINE FOR USAGE SPECIFICALLY MENTIONED IN THIS MANUAL.**

Thank you for choosing a **SAMOA** product.
 As well as the product purchased, you will receive a range of support services
 enabling you to achieve the results desired, quickly and professionally.

A WARNINGS

The table below provides the meaning of the symbols used in this manual in relation to using, earthing, operating, maintaining, and repairing of this equipment.

	<ul style="list-style-type: none"> • Read this operator's manual carefully before using the equipment. • An improper use of this machine can cause injuries to people or things. • Do not use this machine when under the influence of drugs or alcohol. • Do not modify the equipment under any circumstances. • Use products and solvents that are compatible with the various parts of the equipment, and read the manufacturer's warnings carefully. • See the Technical Details for the equipment given in the Manual. • Check the equipment for worn parts once a day. If any worn parts are found, replace them using ONLY original spare parts. • Keep children and animals away from work area. • Comply with all safety standards.
	<ul style="list-style-type: none"> • It indicates an accident risk or serious damage to equipment if this warning is not followed.
   	<p>FIRE AND EXPLOSION HAZARD</p> <ul style="list-style-type: none"> • Solvent and paint fumes in work area can ignite or explode. • To help prevent fire and explosion: <ul style="list-style-type: none"> - Use equipment ONLY in well ventilated area. - Eliminate all ignition sources, such as pilot lights, cigarettes and plastic drop cloths (potential static arc). - Ground equipment and conductive objects. - Use only grounded hoses. - Do not use trichloroethane, methylene chloride, other halogenated hydrocarbon solvents or fluids containing such solvents in pressurized aluminium equipment. Such use can cause serious chemical reaction and equipment rupture, and result in death, serious injury, and property damage. - Do not form connections or switch light switches on or off if the air contains inflammable fumes. • If electrical shocks or discharges are encountered the operation being carried out using the equipment must be stopped immediately. • Keep a fire extinguisher at hand in the immediate vicinity of the work area.
	<ul style="list-style-type: none"> • It indicates wound and finger squashing risk due to movable parts in the equipment. • Tenersi lontano dalle parti in movimento. • Do not use the equipment without the proper protection. • Before any inspection or maintenance of the equipment, carry out the decompression procedure explained in this manual, and prevent any risk of the equipment starting unexpectedly.
 	<ul style="list-style-type: none"> • Report any risk of chemical reaction or explosion if this warning has not been given. • (IF PROVIDED) There is a risk of injury or serious lesion related to contact with the jet from the spray gun. If this should occur, IMMEDIATELY contact a doctor, indicating the type of product injected. • (IF PROVIDED) Do not spray before the guard has been placed over the nozzle and the trigger on the spray gun. • (IF PROVIDED) Do not put your fingers in the spray gun nozzle. • Once work has been completed, before carrying out any maintenance, complete the decompression procedure.
	<ul style="list-style-type: none"> • It indicates important recommendations about disposal and recycling process of products in accordance with the environmental regulations.
    	<ul style="list-style-type: none"> • Mark any clamps attached to earth cables. • Use ONLY 3-wire extension cords and grounded electrical outlets. • Before starting work make sure that the electrical system is grounded and that it complies with safety standards. • High-pressure fluid from gun, hose leaks, or ruptured components will pierce skin. • To help prevent injection, always: <ul style="list-style-type: none"> - (IF PROVIDED) Engage trigger lock when not spraying. - (IF PROVIDED) Do not put your hand over the spray tip. Do not stop or deflect leaks with your hand, body or other. - (IF PROVIDED) Do not point gun at anyone or at any part of the body. - (IF PROVIDED) Never spray without tip guard. - Do pressure relief if you stop spraying or being servicing sprayer and before any maintenance operations. - Do not use components rated less than sprayer Maximum Working Pressure. - Never allow children to use this unit - (IF PROVIDED) Brace yourself; gun may recoil when triggered. • If high pressure fluid pierces your skin, the injury might look like "just a cut", but it is a serious wound! Get immediate medical attention.
   	<ul style="list-style-type: none"> • It is obligatory to wear suitable clothing as gloves, goggles and face shield. • Wear clothing that complies with the safety standards in force in the country in which the equipment is used. • Do not wear bracelets, earrings, rings, chains, or anything else that may hinder the operator's work. • Do not wear clothing with wide sleeves, scarves, ties, or any other piece of clothing that could get tangled up in moving parts of the equipment during the work, inspection, or maintenance cycles.

B WORKING PRINCIPLE

OMEGA 40:1 EXT V2 is a high pressure pneumatic pump used for extrusion and transferring of high viscosity products.

OMEGA pump is essentially constituted of an air motor and a structure called «material pumping group» or simply «pumping group».

In the pneumatic motor, compressed air causes the vertical reciprocating movement of the motor piston; this movement is transmitted through a connecting rod to the material pumping piston ending with a shovel plate allowing to suck very visous products.

The ratio 40:1 means that the outlet pressure of material is 40 times higher than the pump feed air pressure.



Fig. 1B

Connection sleeve

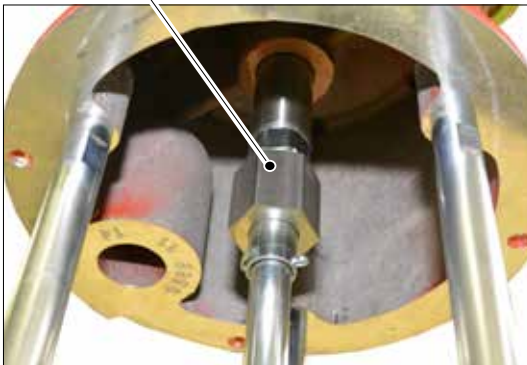

Fig. 2B

Lubrificant cup

Ring gasket press



Fig. 3B



Fig. 4B

C TECHNICAL DATA

	OMEGA 40:1 EXT V2
Air pressure range	3-8 bar / 40-120 psi
Maximum fluid outlet pressure	320 bar / 4.800 psi
Delivery per cycle	125 cm ³
Delivery at 60 cycles per minute	7,5 l/min
Air inlet thread	3/4" BSPP (M)
Fluid outlet thread	1" BSP (F)
Lower pump material	Galvanized steel
	INOX AISI 303+420B
Plunger material	INOX AISI 420B
Seals material	PTFE+PE 1000
Air motor piston diameter and stroke	Ø 7"-4 3/4" / Ø 180mm - 120mm

COD.	DESCRIPTION
96405	OMEGA 40:1 extrusion pump, short
96404	OMEGA 40:1 extrusion pump, long
96407	OMEGA 40:1 extrusion pump, stainless steel short
96406	OMEGA 40:1 extrusion pump, stainless steel long



Always observe these instructions carefully when evaluating the product compatibility and in case of disposal of some parts of the pump no more usable, in order to meet the environmental regulations on recycling process.

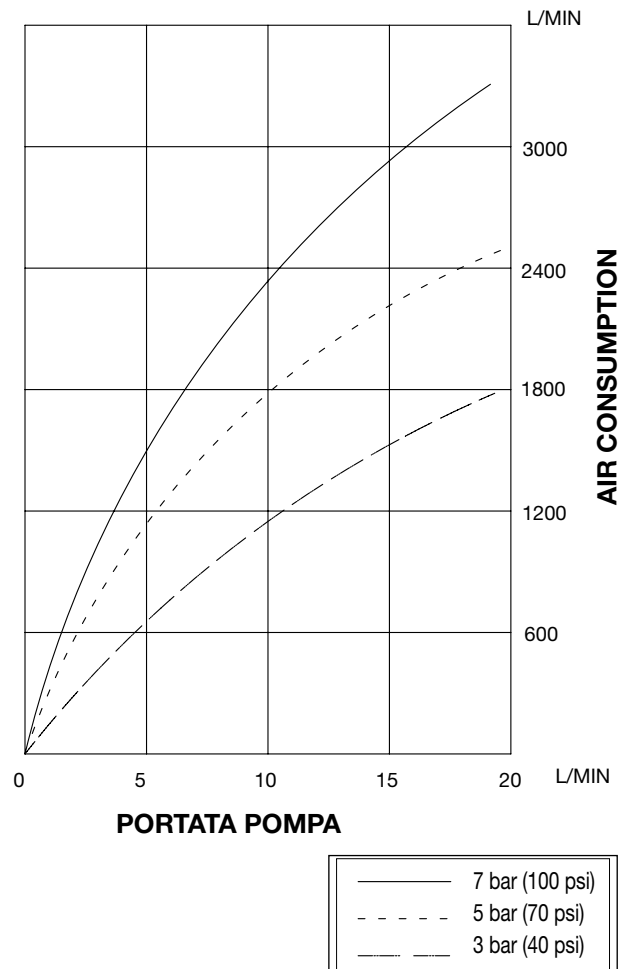
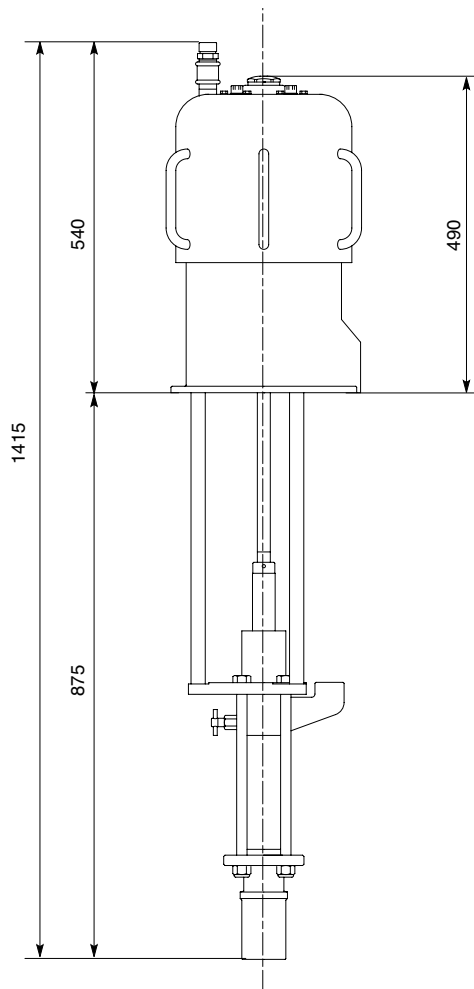

D DESCRIPTION OF THE EQUIPMENT



Fig. 1D



Fig. 2D



Fig. 3D

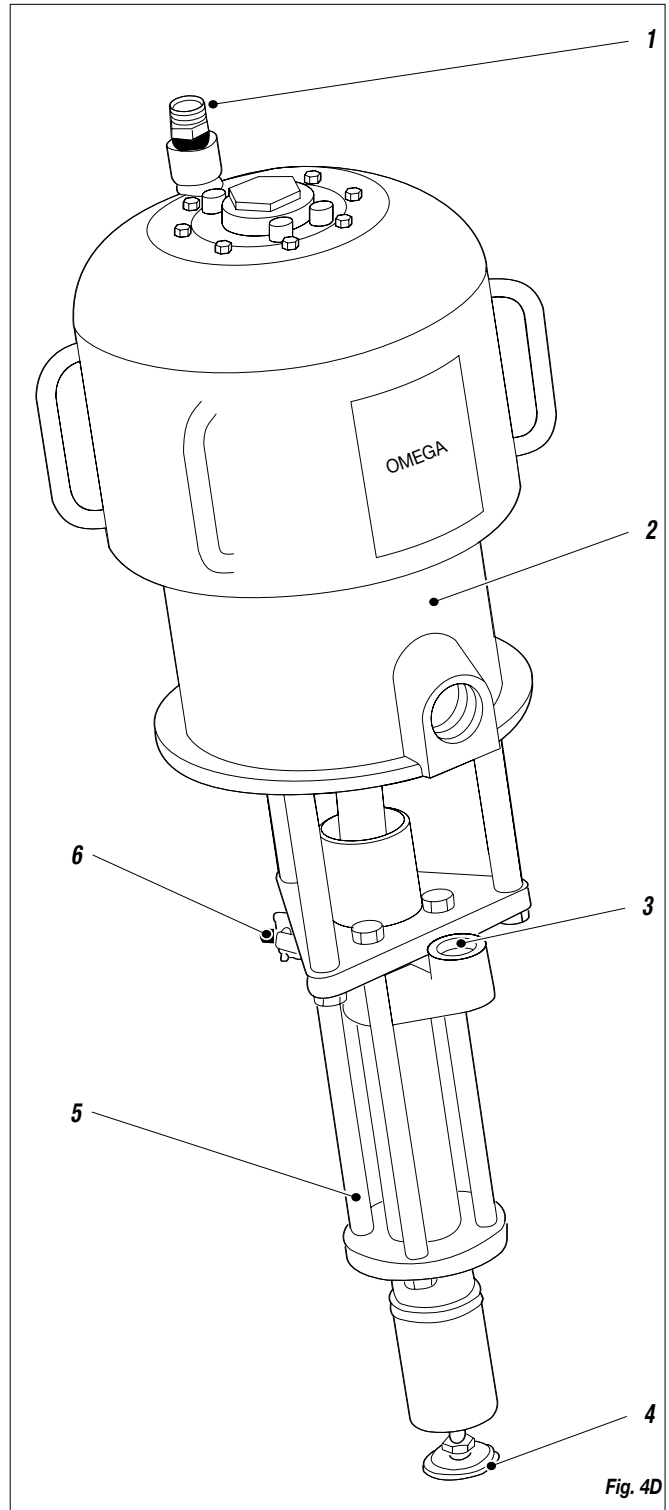

Fig. 4D

Pos.	Description
1	Pump feed air inlet
2	Pneumatic motor
3	Material outlet
4	Input product
5	Material pumping group

Pos.	Description
6	Escape valve
7	Lubrificant cap
8	Ring gasket press
9	Connection sleeve

E TRANSPORT AND UNPACKING

- The packed parts should be handled as indicated in the symbols and markings on the outside of the packing.
- Before installing the equipment, ensure that the area to be used is large enough for such purposes, is properly lit and has a clean, smooth floor surface.
- The user is responsible for the operations of unloading and handling and should use the maximum care so as not to damage the individual parts or injure anyone.
To perform the unloading operation, use only qualified and trained personnel (truck and crane operators, etc.) and also suitable hoisting equipment for the weight of the installation or its parts.
Follow carefully all the safety rules.
The personnel must be equipped with the necessary safety clothing.
- The manufacturer will not be responsible for the unloading operations and transport to the workplace of the machine.
- Check the packing is undamaged on receipt of the equipment. Unpack the machine and verify if there has been any damage due to transportation.
In case of damage, call immediately the manufacturer and the Shipping Agent. All the notices about possible damage or anomalies must arrive timely within 8 days at least from the date of receipt of the plant through Registered Letter to the Shipping Agent and to the manufacturer.
- The disposal of packaging materials is a customer's competence and must be performed in accordance with the regulations in force in the country where the plant is installed and used. It is nevertheless sound practice to recycle packaging materials in an environment-friendly manner as much as possible.

F SAFETY RULES

- THE EMPLOYER SHALL TRAIN ITS EMPLOYEES ABOUT ALL THOSE RISKS STEMMING FROM ACCIDENTS, ABOUT THE USE OF SAFETY DEVICES FOR THEIR OWN SAFETY AND ABOUT THE GENERAL RULES FOR ACCIDENT PREVENTION IN COMPLIANCE WITH INTERNATIONAL REGULATIONS AND WITH THE LAWS OF THE COUNTRY WHERE THE PLANT IS USED.
- THE BEHAVIOUR OF THE EMPLOYEES SHALL STRICTLY COMPLY WITH THE ACCIDENT PREVENTION AND ALSO ENVIRONMENTAL REGULATIONS IN FORCE IN THE COUNTRY WHERE THE PLANT IS INSTALLED AND USED.
- KEEP YOUR WORK PLACE CLEAN AND TIDY. DISORDER WHERE YOU ARE WORKING CREATES A POTENTIAL RISK OF ACCIDENTS.



Read carefully and entirely the following instructions before using the product. Please save these instructions in a safe place.

The unauthorised tampering/replacement of one or more parts composing the machine, the use of accessories, tools, expendable materials other than those recommended by the Manufacturer can be a danger of accident.

The Manufacturer will be relieved from tort and criminal liability.

- ALWAYS KEEP PROPER BALANCE AVOIDING UNUSUAL STANCE.
- BEFORE USING THE TOOL, ENSURE THERE ARE NOT DAMAGED PARTS AND THE MACHINE CAN WORK PROPERLY.
- ALWAYS FOLLOW THE INSTRUCTIONS ABOUT SAFETY AND THE REGULATIONS IN FORCE.
- KEEP THOSE WHO ARE NOT RESPONSIBLE FOR THE EQUIPMENT OUT OF THE WORK AREA.
- NEVER EXCEED THE MAXIMUM WORKING PRESSURE INDICATED.
- NEVER POINT THE SPRAY GUN AT YOURSELVES OR AT OTHER PEOPLE. THE CONTACT WITH THE CASTING CAN CAUSE SERIOUS INJURIES.
- IN CASE OF INJURIES CAUSED BY THE GUN CASTING, SEEK IMMEDIATE MEDICAL ADVICE SPECIFYING THE TYPE OF THE PRODUCT INJECTED. NEVER UNDERVALUE A WOUND CAUSED BY THE INJECTION OF A FLUID.
- ALWAYS DISCONNECT THE SUPPLY AND RELEASE THE PRESSURE IN THE CIRCUIT BEFORE PERFORMING ANY CHECK OR PART REPLACEMENT OF THE EQUIPMENT.
- NEVER MODIFY ANY PART IN THE EQUIPMENT. CHECK REGULARLY THE COMPONENTS OF THE SYSTEM. REPLACE THE PARTS DAMAGED OR WORN.
- TIGHTEN AND CHECK ALL THE FITTINGS FOR CONNECTION BETWEEN PUMP, FLEXIBLE HOSE AND SPRAY GUN BEFORE USING THE EQUIPMENT.
- ALWAYS USE THE FLEXIBLE HOSE SUPPLIED WITH STANDARD KIT. THE USE OF ANY ACCESSORIES OR TOOLING OTHER THAN THOSE RECOMMENDED IN THIS MANUAL, MAY CAUSE DAMAGE OR INJURE THE OPERATOR.
- THE FLUID CONTAINED IN THE FLEXIBLE HOSE CAN BE VERY DANGEROUS. HANDLE THE FLEXIBLE HOSE CAREFULLY. DO NOT PULL THE FLEXIBLE HOSE TO MOVE THE EQUIPMENT. NEVER USE A DAMAGED OR A REPAIRED FLEXIBLE HOSE.



The high speed of travel of the product in the hose can create static electricity through discharges and sparks. It is suggested to earth the equipment.

The pump is earthed through the earth cable of the supply.

The gun is earthed through the high pressure flexible hose.

All the conductors near the work area must be earthed.

- NEVER SPRAY OVER FLAMMABLE PRODUCTS OR SOLVENTS IN CLOSED PLACES.
- NEVER USE THE TOOLING IN PRESENCE OF POTENTIALLY EXPLOSIVE GAS.



Always check the product is compatible with the materials composing the equipment (*pump, spray gun, flexible hose and accessories*) with which it can come into contact. Never use paints or solvents containing Halogen Hydrocarbons (as the *Methylene Chloride*).

If these products come into contact with aluminium parts can provoke dangerous chemical reactions with risk of corrosion and explosion.



Avoid approaching too much to the pump piston rod when the pump is working or under pressure. A sudden movement of the piston rod can cause wounds or finger squashing.



If the product to be used is toxic, avoid inhalation and contact by using protection gloves, goggles and proper face shields.



Take proper safety measures for the protection of hearing in case of work near the plant.



The machine is equipped with an anti-freeze system that allows it to work even at very low temperatures. However, after a few minutes of operation, the upper metal outer surface cools dramatically.

Avoid touching the area indicated.

Contact of the skin with the low-temperature area may cause frostbite. Common working clothes and leather gloves provide adequate protection.

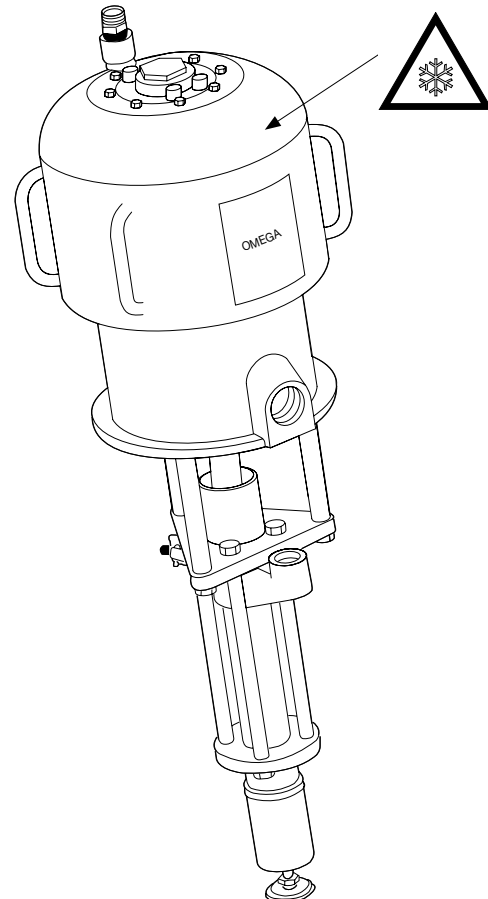

Fig. 1F

G CONDITIONS OF GUARANTEE



The conditions of guarantee do not apply in the following situations:

- improper washing and cleaning of components causing malfunction, wear or damage to the equipment or any of its parts;
- improper use of the equipment;
- use that does not conform with applicable national legislation;
- incorrect or faulty installation;
- modifications, interventions and maintenance that have not been authorised by the manufacturer;
- use of non-original spare parts or parts that do not correspond to the specific model;
- total or partial non-compliance with the instructions provided.

H TYPICAL INSTALLATION

The pump can be installed on pneumatic double post ram whit shovel plate.

The double post ram allows to suck the product directly from the drum and also to replace quickly the drum itself. The shovel plate, fastened at the base of the pump, compresses the material ensuring a constant flow of product. In addition, it protects the material not yet sucked against powder, moisture and drying caused by contact with air.

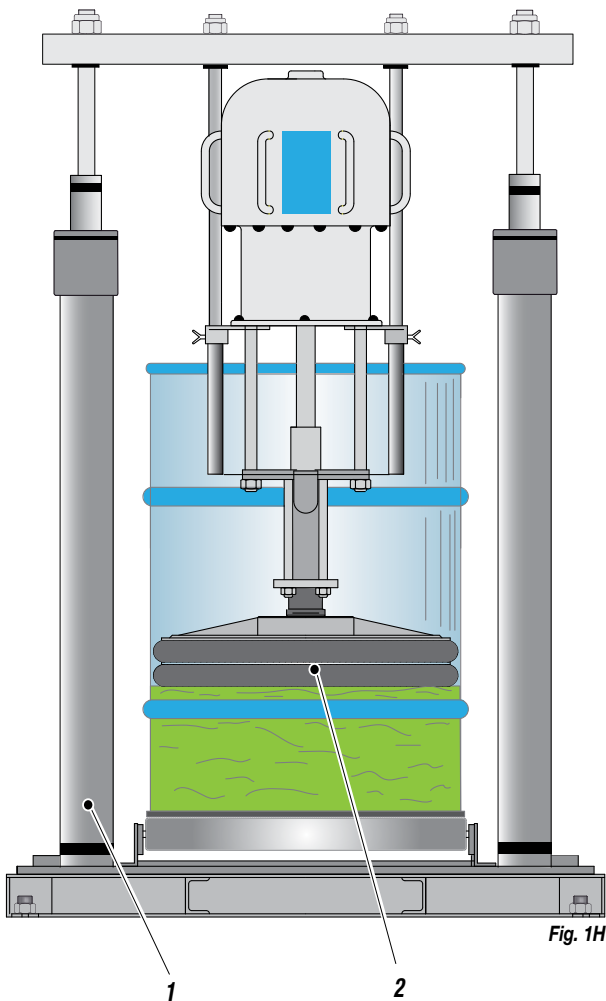

Fig. 1H

Pos.	Code	Description
1	510000	Double post ram for 200 litres drums
2	510100	Shovel plate in cast iron complete with double gasket

I SETTING-UP

PUMP FASTENING ON THE HOIST

For the correct fastening of the pump on the ram, follow the procedure described in the manual for use and maintenance of the double post ram.

CONNECTION TO THE FEED AIR

For pump feed use a hose with an internal diameter no lower than 20 mm.



Install at the pump inlet an air pressure regulator (it is suggested complete with condensate filter and lubricator). The outlet pressure of the material is 40 times the inlet pressure of the pump feed air. Therefore, it is extremely important to adjust the value of the feed air pressure.

CONNECTION OF THE MATERIAL OUTLET HOSE

Connect the high pressure hose at the outlet of the pump. It is recommended to tighten the fittings.

J WORKING



Check all the fittings for connection of the different components (pump, flexible hose, spray gun, etc.) before using the equipment.

- Dip the material pumping hose into the product tank (if the pump is fixed on the double post ram, follow the procedure described in the manual of use and maintenance of the double post ram).
- Make the compressed air flow into the pump. It is advisable to adjust air pressure to minimum necessary for its continuous working.
- When the product chamber is full, pump will start working and stopping. Pump will start working again any time the trigger of the spray gun is pressed or the delivery valve is open.
- In case of difficult suction of the pump, slowly open the bleeder valve and close it when some material comes out
- The pump has been adjusted at our factory with light mineral oil and a part of it could be left inside the pumping element. Point the spray gun or the delivery valve at the tank and drain the product left inside the pump till the material to be used has come out.



Always avoid pump idling: this operation could damage the pneumatic motor and the seals.

- In case of long inactivity during the use with the plant (for example, all night long at the end of the working day), ensure the product you are using can be left inside the pump and the different pipes without drying. In this case, it is enough to stop the air supply to the pump and drain the residual pressure in the circuit acting on the delivery valve or on the pump bleeder valve.

K CLEANING AT THE END OF THE WORK

By “cleaning at the end of the work” we mean the cleaning to carry out in case of use with a different product or if a long period of downtime is foreseen.

- Stop the air supply to the pump.
- Dip the material pumping hose into the washing solvent tank (check its chemical compatibility with the product being used).
- Make compressed air flow into the pump. It is advisable to adjust the air pressure to minimum necessary to its continuous working.
- Point the spray gun or the delivery valve at a container and drain all the product left inside the pump till a clean solvent comes out.
- Now, stop the air supply to the pump and drain the residual pressure.
- In case of long downtime, we suggest to duly suck and leave light mineral oil inside the pumping unit.



Store possible dangerous fluids in proper containers. Their disposal must be performed in accordance with the regulations in force about the industrial waste goods.

L ROUTINE MAINTENANCE



Always close the compressed air supply and release the pressure in the plant before performing any check or maintenance of the pump.

- Check periodically (and each time the pump is operated after a long storage) the packing nut (L2) is not loosened, causing otherwise the coming out of the product. To tighten the packing nut, lift the wet cup (L1) (see illustration below). The packing nut (L2) must be tightened so as to avoid wastes of product, but not excessively to provoke pumping piston seizure and seals wear. In case of persistent coming out of product, replace the seals.
- To prevent the product from drying up on the piston rod, refill the cup (L1) with lubricant (compatible with the product used).
- Check periodically the air supply to the pump. Ensure the air is always clean and lubricated. In case of installation of a lubricator on the air supply to the pump, it is advisable to keep its cup full of a mixture of water and antifreeze liquid (dilution ratio 4:1).



Fig. 1L

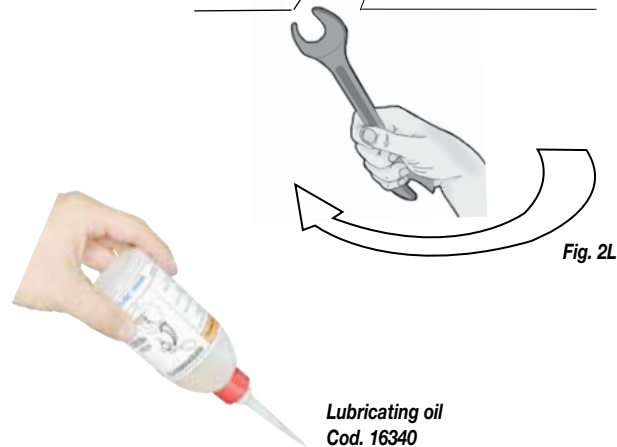

Fig. 2L

Lubricating oil
Cod. 16340

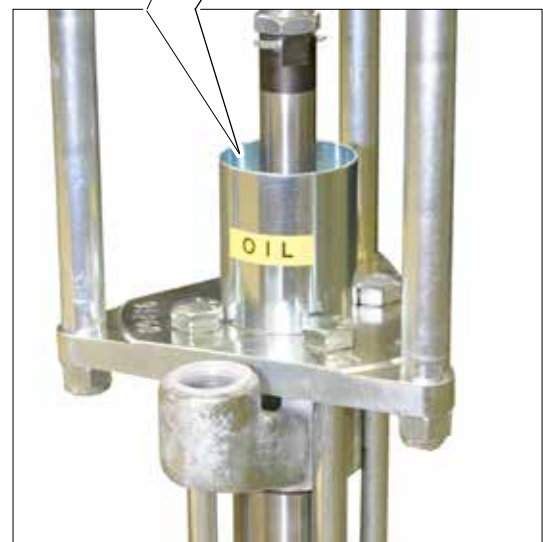

Fig. 3L

M TROUBLESHOOTING

Problem	Possible cause	Solution
The pump does not start	Feeding air is not enough;	Check the air supply. Increase the diameter of the feeding hose;
	Outlet product line clogged;	Clean. Disconnect the outlet product pipe. Feed pump at minimum pressure and check if the pump starts without the outlet pipe;
	Dried product inside the pumping element;	Disassemble the pumping group and clean;
	Pneumatic motor blocked in the cycle reversal position;	Turn the plug counterclockwise and push downwards the valve body. Use a metal rod and a mallet;
	Parts failure of the pneumatic motor;	Disassemble the motor and check;
Accelerated working and no pressure of the pump	There is no product;	Add product;
	The pump sucks air;	Open the exhausting valve. For the version on air hoist, follow the instructions in the relevant manual;
	Feeding air is not enough;	Increase the feeding air pressure;
	Suction valve worn or partially clogged;	Disassemble the suction valve. Clean and/or replace if necessary the worn parts;
	Outlet valve worn or partially clogged;	Disassemble the outlet valve. Clean and/or replace if necessary the worn parts;
The pump works, but the product is not flowing enough	Suction valve worn or partially clogged;	Disassemble the suction valve. Clean and/or replace the worn parts;
	Outlet product line clogged;	Clean. Disconnect the outlet product pipe. Feed pump at minimum pressure and check if delivery increases without the outlet pipe;
	The feed air pressure is too low;	Increase air pressure;
Leakage of product from the lubricating cup	Upper gaskets worn;	Tighten the packing nut. In case of persistent waste of product, replace the upper gaskets of the pumping unit;



Always close the compressed air supply and release the pressure in the plant before performing any check or replacement of parts of the pump.

N DISASSEMBLY OF THE PNEUMATIC MOTOR



Always close the compressed air supply and release the pressure in the plant before disassembling the pneumatic motor of the pump.

- Unscrew the coupling sleeve so as to disconnect the pumping group from the motor.
- Disconnect the air feeding pipe to the pump.
- Unscrew the fitting (N1) and the sleeve (N2).
- Turn counterclockwise the screws (N3) [take care to the washers (N4)] and remove the covering (N5).
- Unscrew the two ring nuts (N6) from the support (N7).
- Turn counterclockwise the screws (N8) [take care to the washers (N9)] and remove the support (N7) together with the rollers (N10) and the pins (N11).
- Extract the spring (N12), the spring guide rod (N13) and the roller pushing piston (N14). Ensure the spring slides freely on the guide rod, the guide rod slides into the roller pushing piston and this last slides into the mount hole.
- Check the roller (N10) and the pin (N11) are undamaged. Replace them if damaged.
- Remove and check the rubber pad (N15) and the washer (N16).

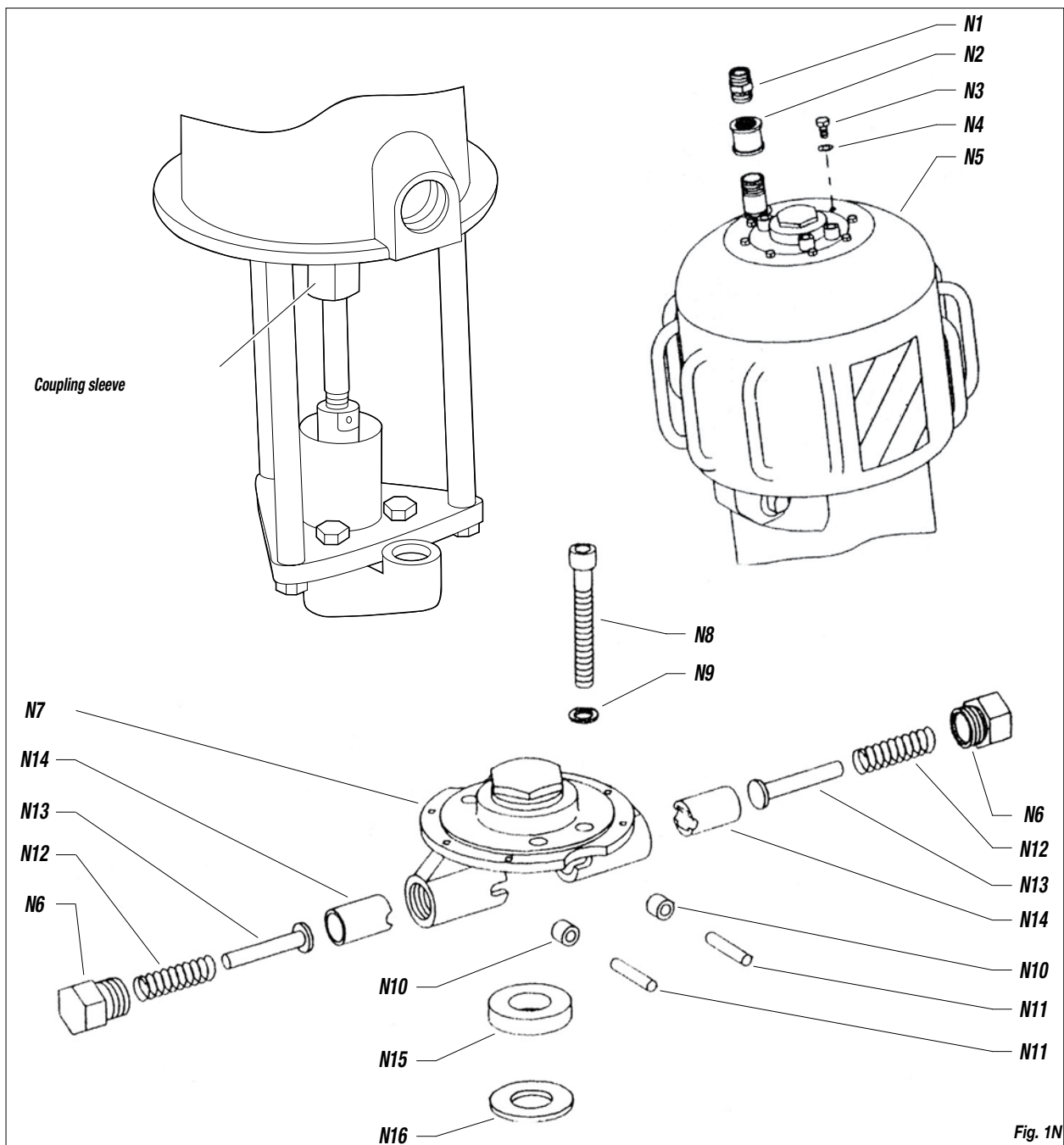
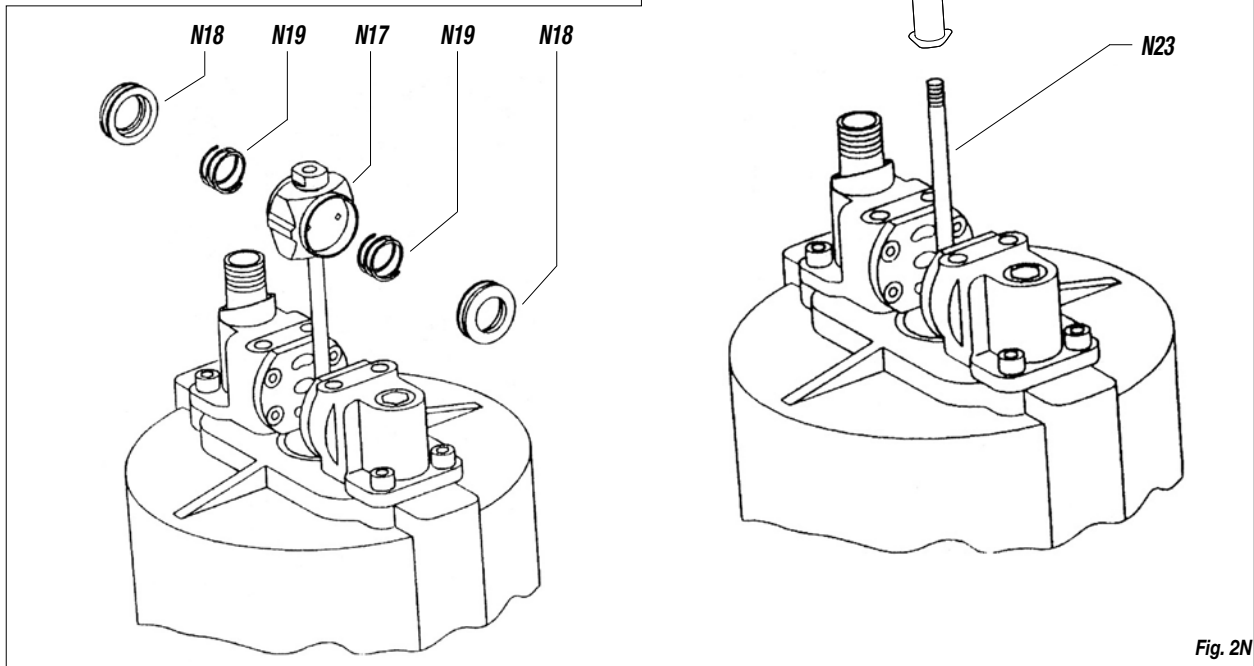

Fig. 1N

- Pull upwards the seat (N17) so as to take out the valves (N18) and the springs (N19) (clean and/or replace the worn parts).
- Unscrew the lock nut (N20) [take care of the washer (N21)] by keeping the bush (N22) blocked using a wrench.
- Remove the seat (N23) from the rod (N17).
- Unscrew the bush (N22) (if necessary, keep the rod (N23) blocked on the threaded part using pliers with the bits wrapped in rags to avoid damage to thread).



- Remove the screws (N24) [take care to the washers (N25)], a manifold (N26) and the gasket (N27).



Handle with care the manifold. The edges of its plate are very sharp.
Important: do not remove the other manifold if not necessary (it will facilitate the fastening of the manifold removed).

- Using a screwdriver, remove the washer (N28) and the rubber pad (N29).

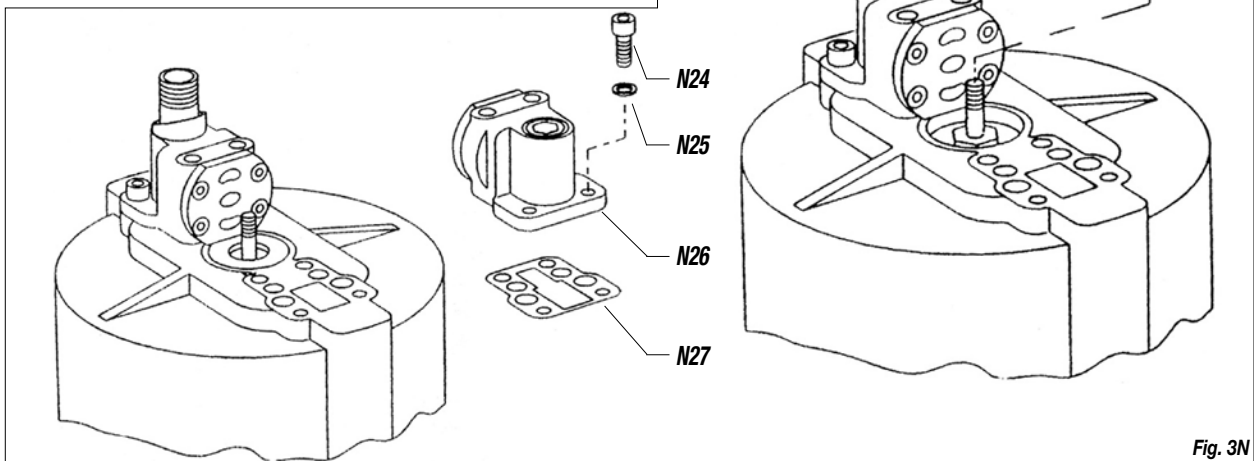

- Turn counterclockwise the rod guiding screw (N30) [take care to the washer (N31)] and check the seal inside the screw (N30) is undamaged.
- Take out the screws (N32) [take care of the washers (N33)] and remove carefully the cylinder (N34) (do not bend it during extraction in order to avoid that motor piston may damage the internal surface of the cylinder).

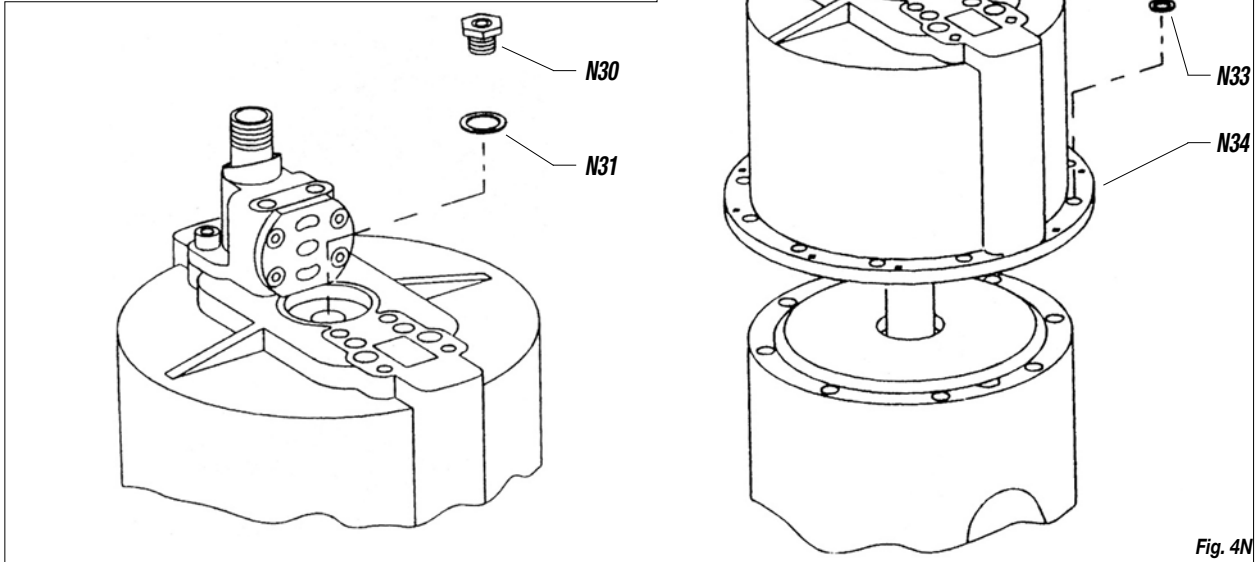

- Extract the motor piston from the motor support (N35).
- Verify the O-ring (N36) is undamaged.
- Tighten the lower edge of the piston rod using pliers (see illustration) and unscrew the fitting (N37) with a wrench.
- Remove the motor rod (N38) and check it is undamaged.
- Rub the motor rod (N38) with vaseline grease before inserting it into the housing of the piston rod.
- Tighten again with pliers the lower edge of the piston rod and screw the fitting (N37) (application of a sealant on the thread is advisable).

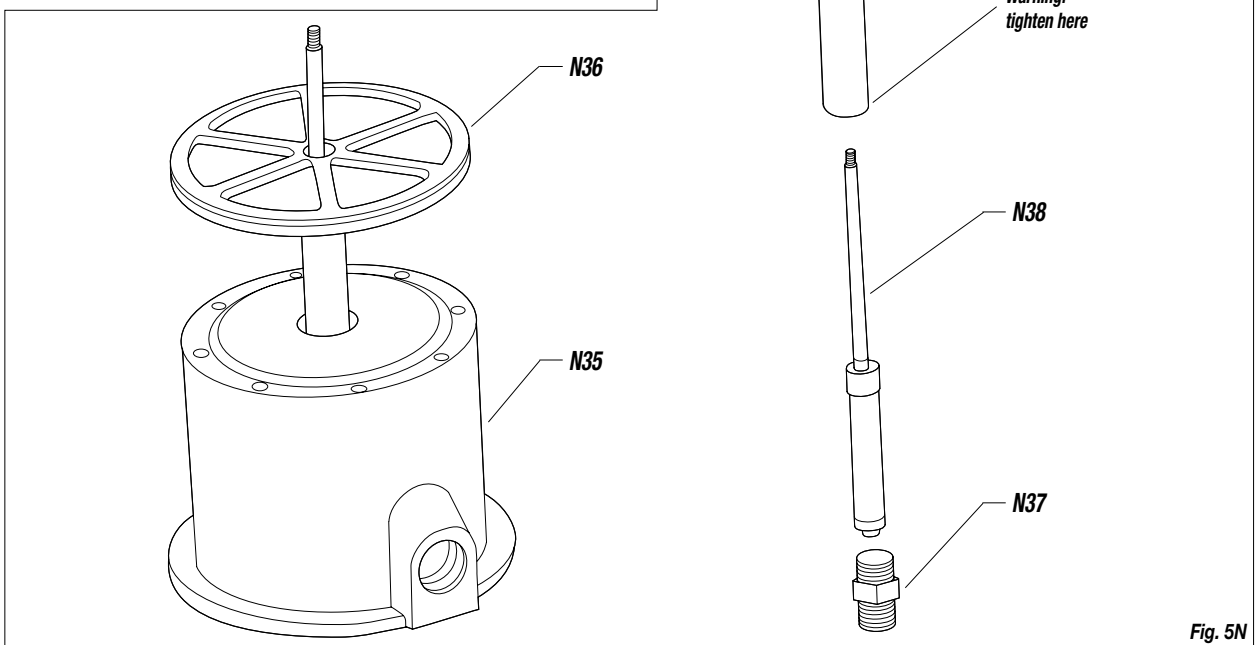

- Check the gas ring inside the support (N39) is undamaged.
- Check the gasket (N40) is undamaged and correctly positioned.
- Coat the inner walls of the cylinder (N41) with a thin layer of vaseline grease.
- Insert the motor piston (N42) into the cylinder (N41) carefully.
- Fasten the cylinder (N41) on the support (N39) (respect the position) and at the same time insert the piston rod into the support.
- Turn clockwise the screws (N43).

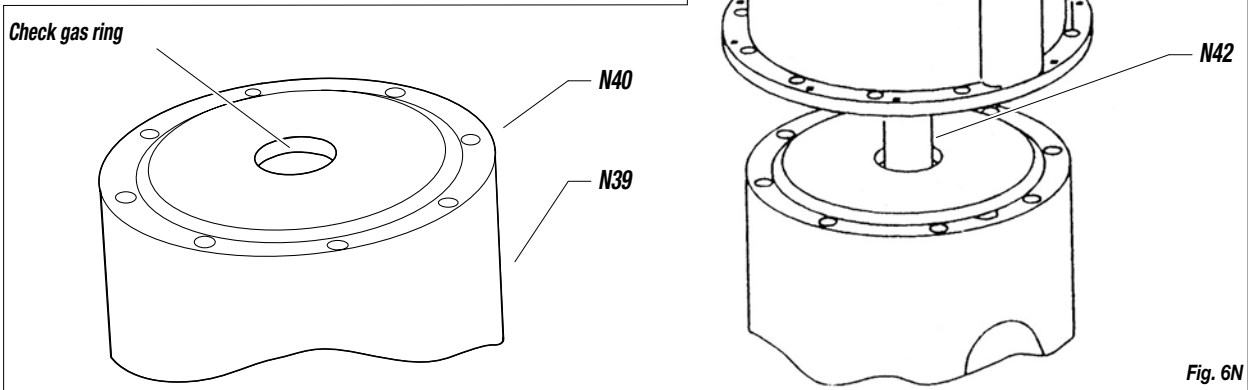

- Insert into the motor rod (N44) the washer (N45).
- Carefully insert the rod guiding screw (N46) into the motor rod (turn it slowly following the direction of the thread) and screw it on the cylinder (N41).
- Insert the rubber pad (N47) and the washer (N48) into the support.
- Screw the bush (N49) on the motor rod (N44). Insert the seat (N50), the washer (N51) and screw the lock nut (N52).

⚠ Adjust bush and lock nut so as the rod (N44) just out of about 1 mm from the lock nut (see illustration).

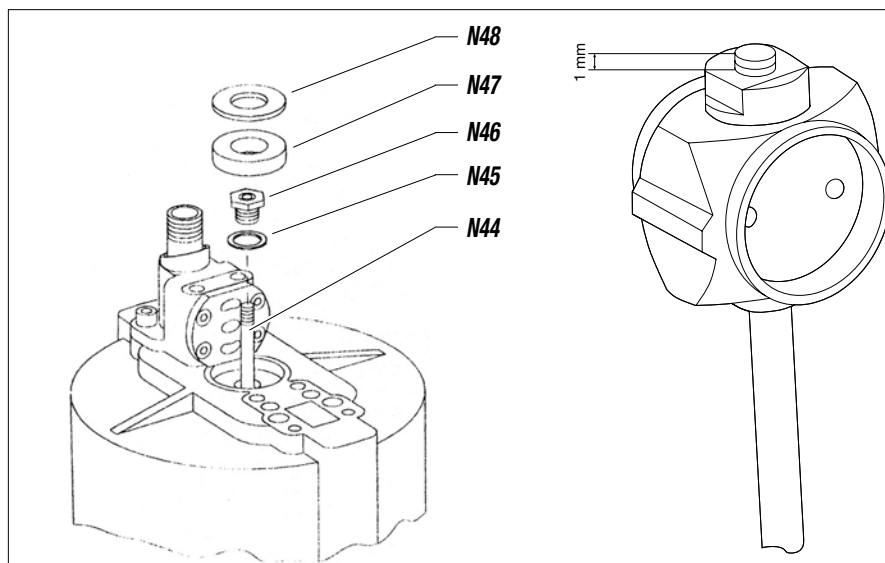
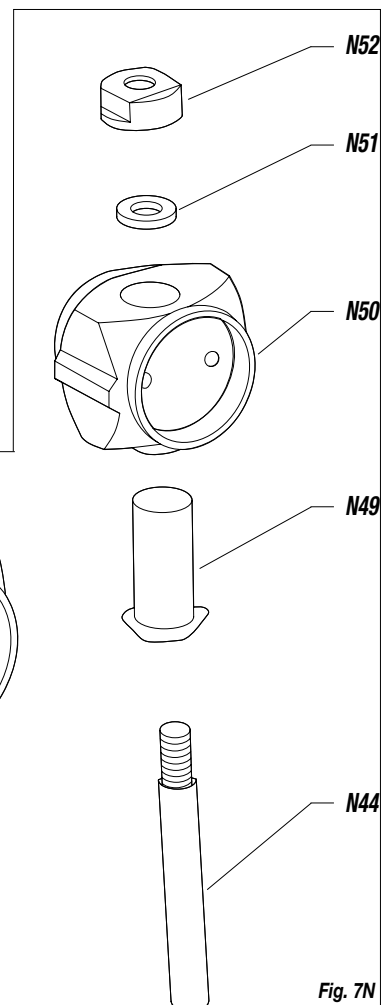

- Insert the springs (N54) and the valves (N55) into the seat (N53). Position the seat on the pump support and lay the manifold (N56) on the seat [do not forget the gasket (N57)].
- Fasten the manifold with screws (*do not tighten*) ensuring it is perfectly parallel to the other manifold and the distance between them is 46 mm (see illustration).

The distance between the walls of the manifold and the edge of the seat must be about 0,8 mm.

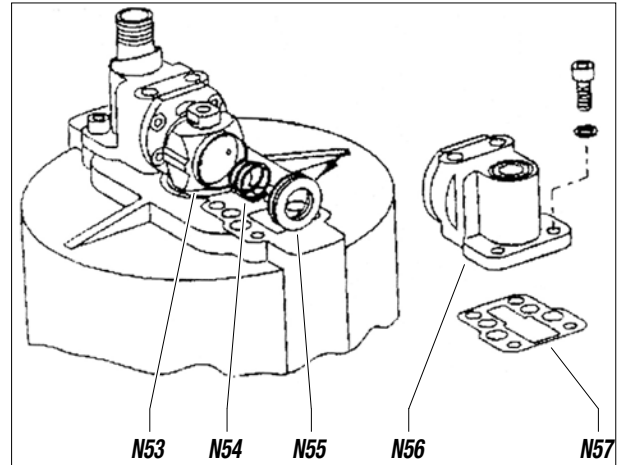

Fig. 9N

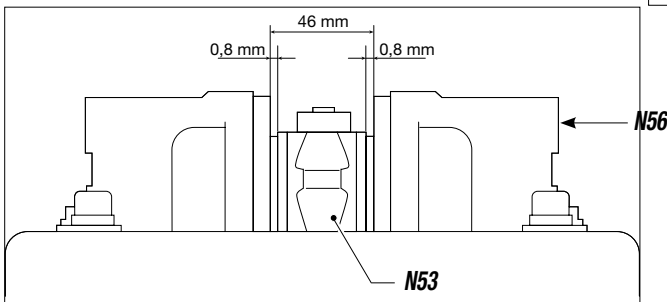

Fig. 8N

- Rub the rollers (N58) and the pins (N59) with vaseline grease and insert them into the mount (N60).
- Rub the rubber pad (N61) and the washer (N62) with vaseline grease and insert them into the mount (N60).
- Grease the roller pushing pistons (N63), the spring guide rods (N64), the springs (N65) and insert them into the mount (N60).
- Fasten without tightening the ring nuts (N66) on the mount (N60).
- Fasten the mount on the manifolds and tighten the screws (N68) [do not forget of washer (N67)].
- Tighten the ring nuts (N66) and the screws (N69).
- Assemble again the covering and all the fittings of the air supply line.

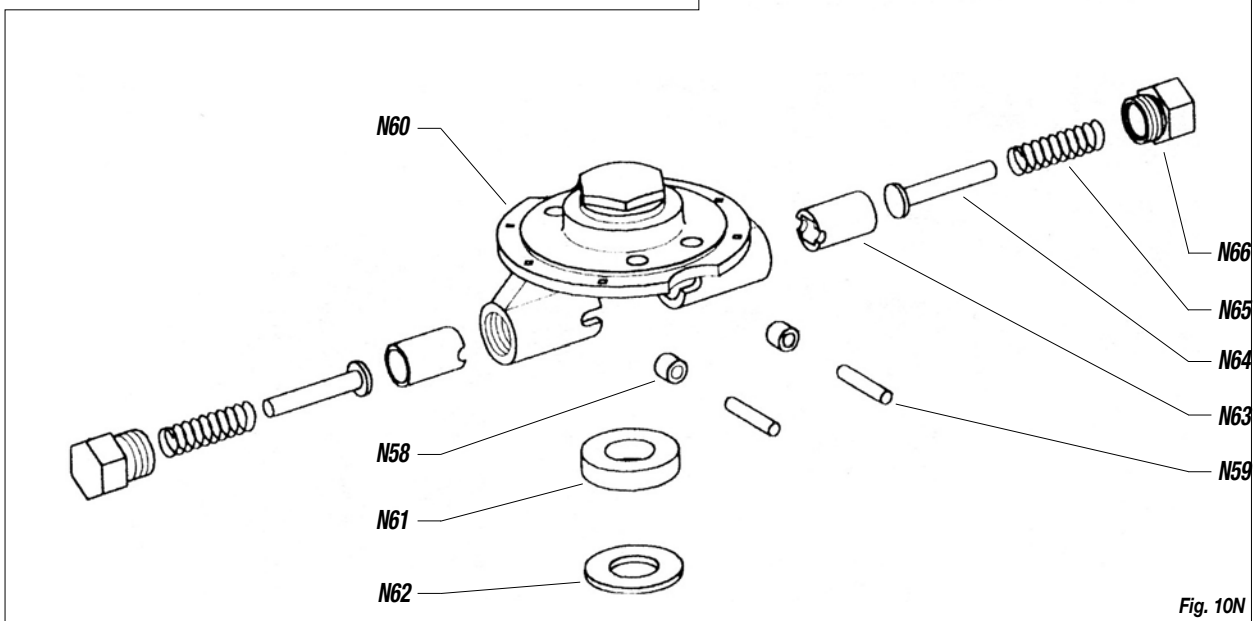
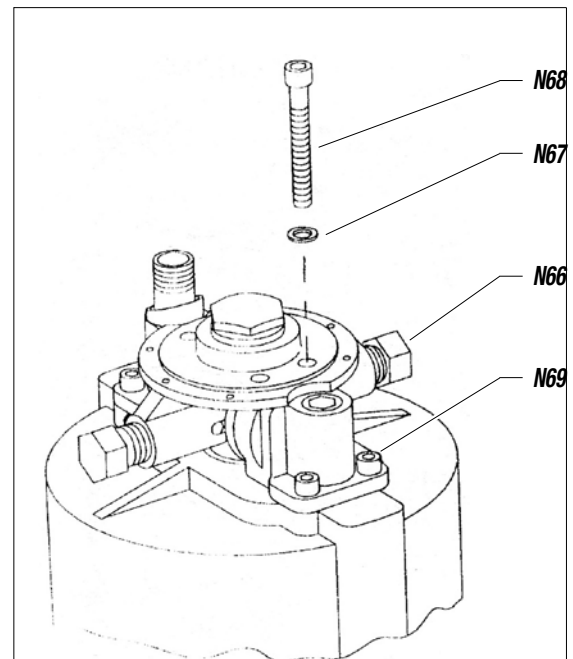

Fig. 10N

0 DISASSEMBLY OF THE PUMPING GROUP



Always close the compressed air supply and release the pressure in the plant before carrying out the disassembly of the pumping group.

- Svitare il manicotto di congiunzione così da staccare il gruppo pompante dal motore.
- Togliere i dadi (033) e staccare il gruppo pompante.
- Togliere la copiglia (05) e rimuovere il tirante di congiunzione.
- Togliere la tazza (08) e svitare la ghiera premi guarnizioni (09).

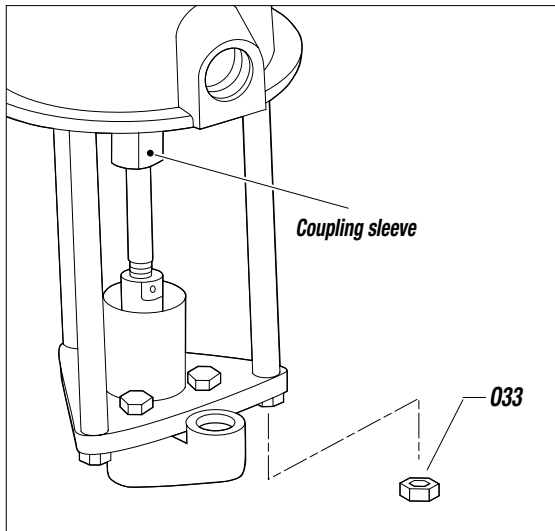

Fig. 10

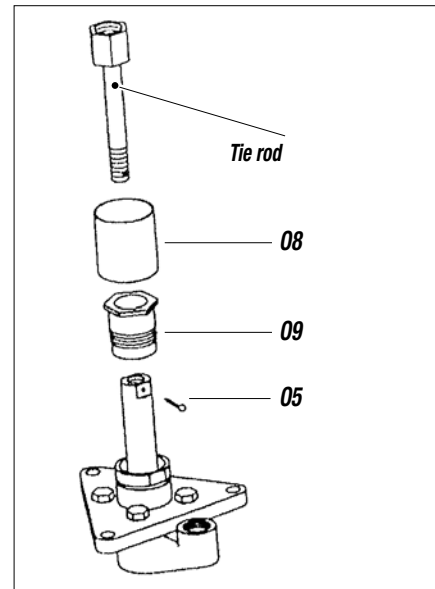

Fig. 20

- Push downwards the motor piston rod till the shovel plate comes out from the housing. Unscrew the nut (37), the plates (36) and (35) and the bush (34).
- Remove the nuts (33) and disconnect the housing (32) [take care of the washer (20)].

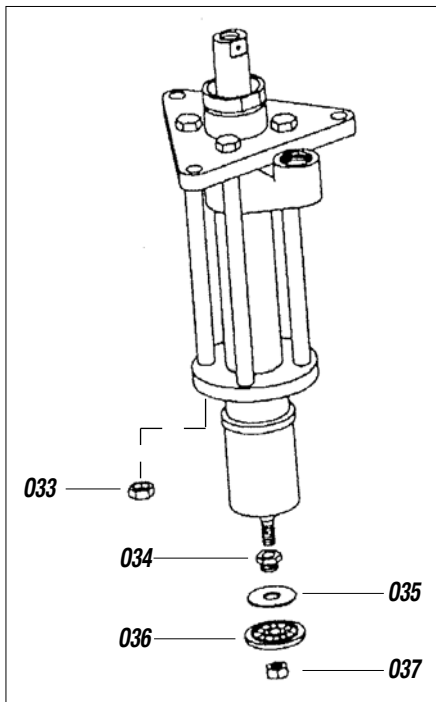

Fig. 30

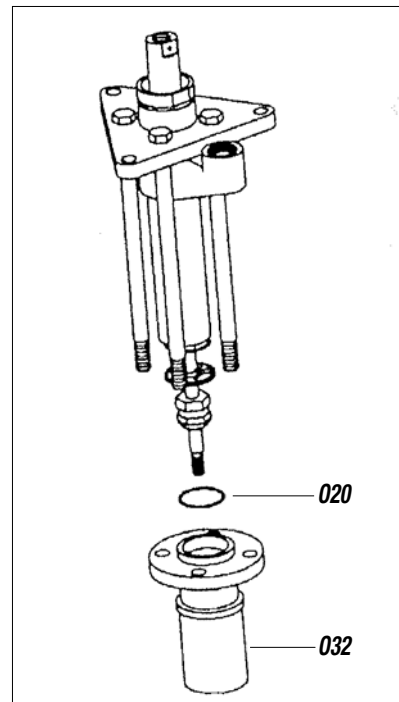

Fig. 40

- Extract the complete shutter group from the rod, the lock (27), the washer (20) and the cylinder (21).
- Disassemble the shutter group and carry out the replacement of the gaskets (refer to the exploded view).
- Extract the tie rods (39) from the top.
- Unscrew the fitting (25) and remove the ball (24), the ring (23), the gaskets (11), the ring (13) and the washer (22) (sostituire i particolari usurati).

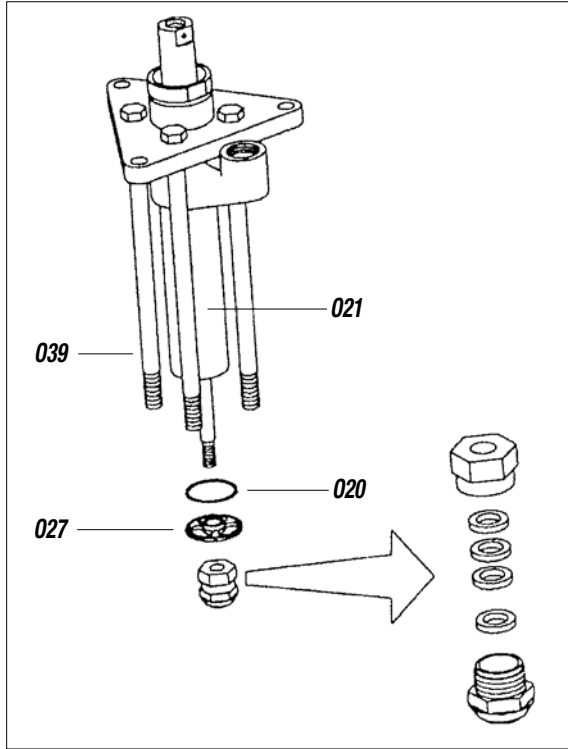

Fig. 50

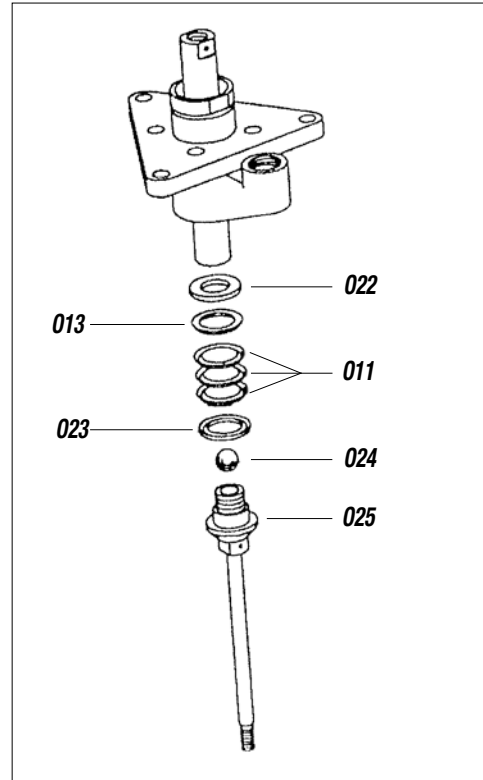

Fig. 60

- Take out the upper gasket pack: the ring (10), the gaskets (11) and the ring (13). replace the worn parts.
- For the correct reassembling of the parts and of the complete pumping group, refer to the exploded view.

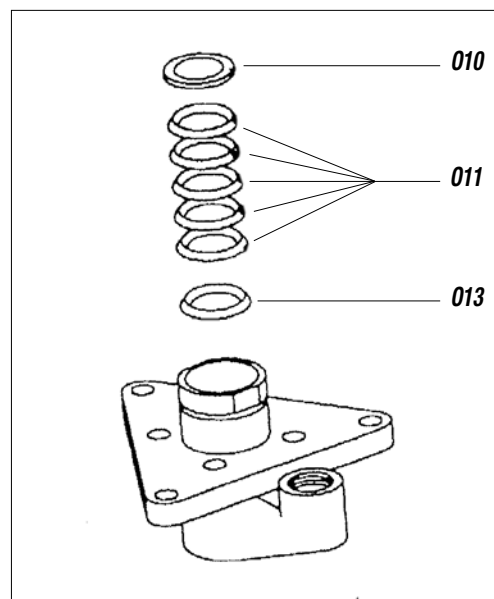

Fig. 70

P EXPLODED VIEW FOR PUMPING GROUP

WARNING: Always indicate code and quantity for each part required.

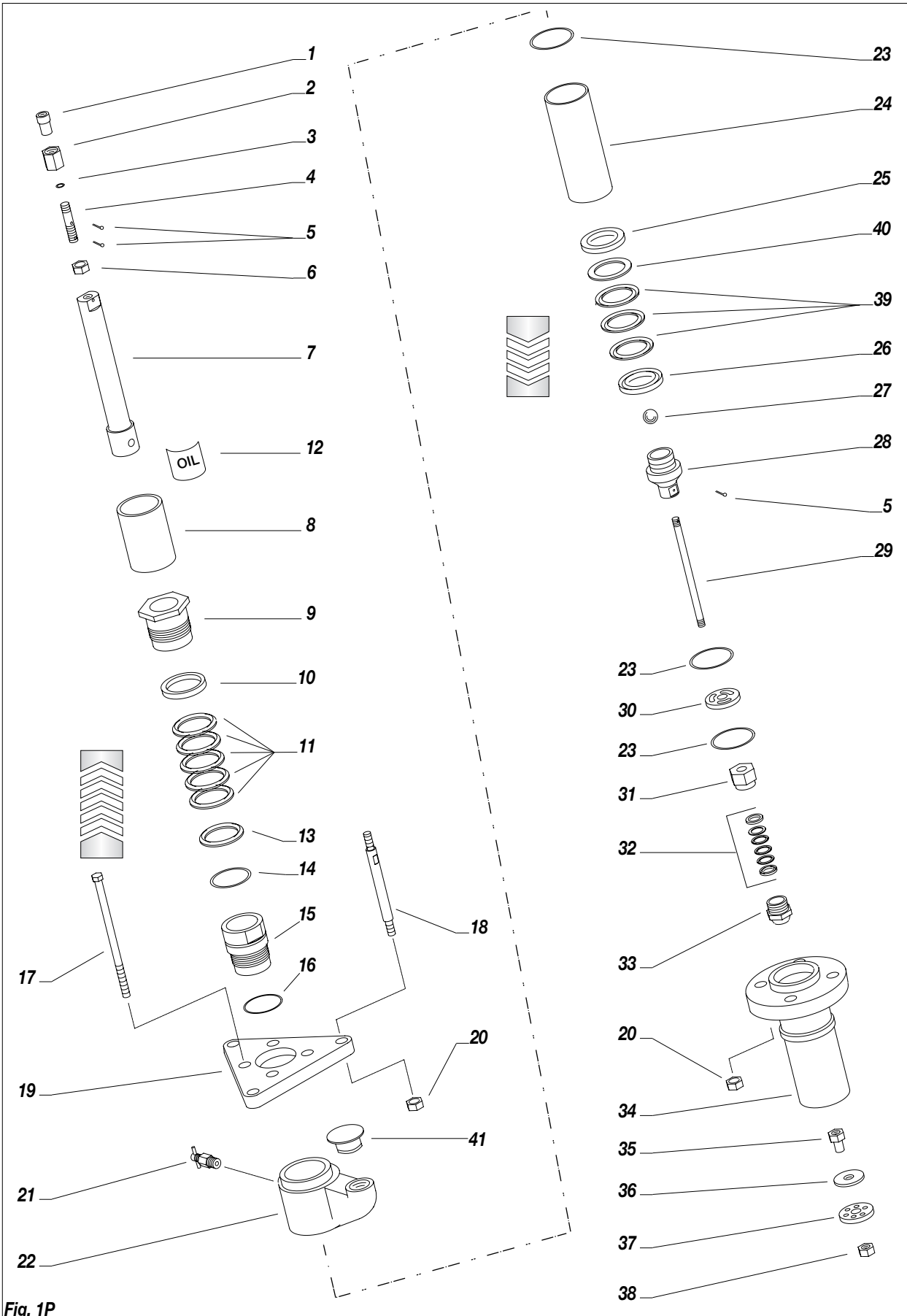

Fig. 1P

Short pumping assembly 96400
Long pumping assembly 96401

Pos.	Code	Description	Q.ty
1	95003	Bush	1
2	95004	Sleeve	1
3	95005	O-ring	1
4	95006	Short tie rod	1
	95942	Long tie rod	1
5	95015	Split pin	3
6	95007	Nut	1
7	96410	Piston rod	1
8	95912	Wet cup	1
9	96413	Press gasket	1
10	96414	Female ring	1
11	96415	Gasket	5
12	96233	Label "OIL"	1
13	96416	Male ring	1
14	95915	O-ring	1
15	96412	Fitting	1
16	95917	Gasket	1
17	95914	Tie rod	4
18	95943	Long tie rod	3
	95943/1	Short tie rod	3
19	95918	Upper flange	1
20	95013	Nut	7
21	95721	Bleeder valve	1
22	95919	Nut	1
23	95925	Washer	3
24	95261	Materialcylinder	1

Pos.	Code	Description	Q.ty
25	95264	Washer	1
26	95267	Female ring	1
27	96094	Ball	1
28	96427	Assembly Fitting/Ball housing	1
	91018	Fitting	1
	96411	Ball housing	1
29	96417	Rod	1
30	96418	Valve lock	1
31	96419	Packing nut	1
32	96435	Shutter gasket pack	1
	96426	Assembly shutter	1
	96420	Gasket housing	1
33	95931	Shutter	1
	95909	Assembly Conveyor	1
	95933	Conveyor	1
34	95932	Ball housing	1
	96424	Bush	1
35	96424	Bush	1
36	95938	Plate	1
37	96423	Plate	1
38	95158	Nut	1
39	95268	Gasket	3
40	95269	Male ring	1
41	100	Plug	1

UPPER GASKET KIT - COD. 96428

Pos.	Description
10	Female ring
11	Gasket
13	Male ring

LOWER GASKET KIT - COD. 42679

Pos.	Description
39	Nut
40	Gasket

EXPLODED VIEW FOR MOTOR GROUP- RIF. 7105

WARNING: Always indicate code and quantity for each part required.

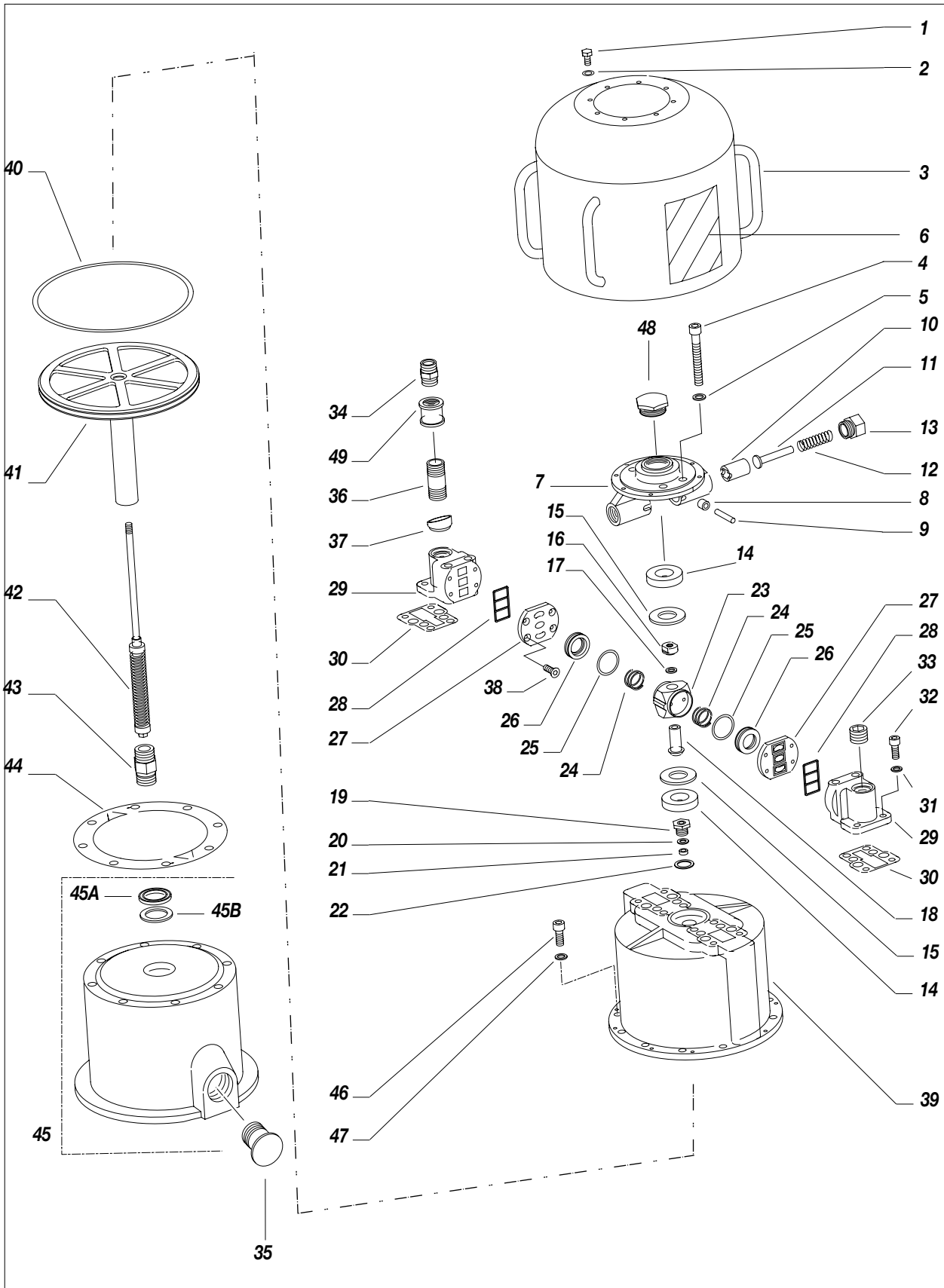

Fig. 1Q

Pos.	Code	Description	Q.ty
1	95062	Screw	8
2	95063	Washer	8
3	7113	Covering	1
4	95065	Screw	4
5	95066	Washer	4
6	7118	Front plate	1
7	95109	Mount	1
8	95092	Roller	2
9	95091	Pin	2
10	95084	Roller pushing piston	2
11	95085	Spring guide	2
12	95086	Spring	2
13	95087	Ring nut	2
14	95093	Rubber pad	2
15	95094	Washer	2
16	95095	Lock nut	1
17	95096	Washer	1
18	95098	Bush	1
19	95078	Trip rod bearing	1
20	95079	Leather ring	1
21	95080	Seal	1
22	33031	Copper washer	1
23	95097	Valve seat	1
24	95077	Spring	2
25	95075	O-ring	2
26	95076	Valve	2

Pos.	Code	Description	Q.ty
27	95073	Valve plate	2
28	95071	Seat valve plate	2
29	95070	Manifold	2
30	95072	Manifold gasket	2
31	95096	Washer	4
32	95068	Screw	4
33	95067	Plugh ³ / ₄	1
34	95090	Fitting	1
35	95229	Plug	1
36	95088	Extension	1
37	95099	Gas ring	1
38	95074	Screw	8
39	7114	Motor cylinder	1
40	7116	O-ring	1
41	95135	Motor piston	1
42	95103	Motor rod	1
43	95104	Fitting	1
44	7111	Gasket	1
45	7120	Complete motor support	1
45a	3314	Gas ring	1
45b	95082	Leather ring	1
46	7112	Screw	8
47	95114	Washer	8
48	96001	Plug	1
49	95944	Plug	1

GASKETS KIT MOTOR - CODE 40345

Pos.	Description	Q.ty
20	Leather ring	1
21	Seal	1
22	Copper washer	1
25	O-ring	2
26	Valve	2
30	Manifold gasket	2
40	O-ring	1
44	Gasket	1
45a	Gas ring	1
45b	Leather ring	1

MOTOR MOVEMENT INVERSION DEVICE - CODE 40066

Pos.	Description	Q.ty
8	Roller	2
9	Pin	2
10	Roller pushing piston	2
25	O-ring	2
26	Valve	2
30	Manifold gasket	2

Pos.	Code	Description	Q.ty
50	95658	"Warning"-Label	1
51	19555	"Atex"-Label	1
52	95136	Adhesive tape	1

Pos.	Code	Description	Q.ty
53	5010	Grounding electric cable	1
54	96210	Grounding - plate	1



Fig. 2Q

50

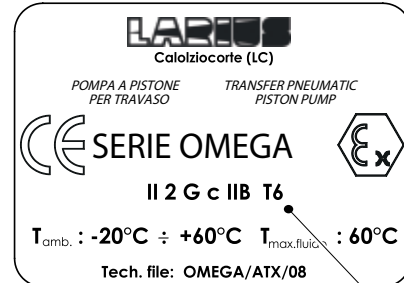

Fig. 3Q

51



Fig. 4Q

52



Fig. 5Q

53

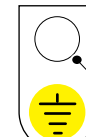

Fig. 6Q

54

R DESCRIPTION

These safety instructions refer to the installation, use and maintenance of OMEGA series pneumatic piston transfer pumps in high risk environments where potentially explosive gasses or vapours are present.



These instructions, along with the indications provided in the user and maintenance manual, must be fully respected.



OMEGA series pneumatic piston pumps are group ii mechanical devices for use in areas where gasses classified as iib (category 2 g) are present. They are designed and built in accordance with the 94/9/ec atex directive, based on the following european standards: en 1127-1, en 13463-1ed en 13463-5.

TECHNICAL CHARACTERISTICS

The main characteristics of the OMEGA series pneumatic piston pumps are provided in the table below

Rapport	Input pressure	Ø Air inlet	Material input	Ø Output material	Max. working pressure	Max. flow
10:1	3÷6 bar	GC 3/4"	Ball	GJ 3/4"	60 bar	32 l/min
23:1	3÷8 bar	GC 3/4"	Ball	GJ 3/4"	185 bar	14 l/min
28:1	3÷8 bar	GC 3/4"	Plate	GJ 1"	225 bar	12 l/min
30:1	3÷8 bar	GC 3/4"	Ball	GJ 3/4"	240 bar	12 l/min
34:1	3÷8 bar	GC 3/4"	Ball	GJ 3/4"	270 bar	11 l/min
40:1	3÷7 bar	GC 3/4"	Plate	GJ 1"	280 bar	7 l/min

- Room temperature: -20°C ÷ +60°C
- Maximum fluid temperature: 60°C
- Maximum number of cycles per minute: 60

MARKINGS

CE II 2 G c IIB T6 • T_{amb}: -20°C ÷ + 60°C • T_{max. fluid}: 60°C • Tech. File: OMEGA/ATX/08

II =	Group II (surfaces)
2 =	Category 2 (zone 1)
G =	Explosive atmosphere containing gasses, vapours or mists
c =	Design safety "c"
T6 =	Temperature class T6
- 20°C ÷ + 60°C	Room temperature
60°C	Maximum process fluid temperature
xxxx/AA	Serial number or lot number (xxxx = PROGRESSIVE/ Year = AA)

Correspondence between hazardous areas, substances and categories

HAZARDOUS AREAS		CATEGORIES ACCORDING TO THE 94/9/CE DIRECTIVE
Gasses, vapours or mists	Zone 0	1G
Gasses, vapours or mists	Zone 1	2G or 1G
Gasses, vapours or mists	Zone 2	3G, 2G or 1G

SAFETY INSTRUCTIONS FOR INSTALLATION IN HAZARDOUS



Read the indications provided in the user and maintenance manual carefully prior to installation. All of the maintenance operations must be performed according to the indications provided in the manual.

- The grounding wire for the pumps indicated above must be grounded using an appropriate anti-loosening connection.
- The tubes used to connect the delivery and suction lines must be either metallic, plastic with metallic braid, or plastic with fabric braid and a suitable grounding conductor.
- The pumps must be installed on properly grounded metallic or antistatic drums.
- The gases or vapours of any flammable liquids present must belong to group IIB.
- Based on the type of use and the substances employed, the user must periodically check for any encrustations and must verify the cleanliness, the wear status and the correct functionality of the pump on a regular basis.
- The user must periodically clean the suction filter in order to prevent any solid materials from entering the pump. The air used to power the pump must be filtered and must come from a SAFE AREA.



OMEGA series pneumatic piston transfer pump cannot work without material. All of the installation and maintenance operations must be performed by qualified personnel.

DECLARATION OF CONFORMITY

We Larius S.r.l.
Via Stoppani, 21
23801 Calolziocorte (LC)

declare under our sole responsibility that the product:

Pneumatic piston transfer pump OMEGA series

to which this declaration relates complies with the following directives:

- Directive 94/9/EC (ATEX)

The conformity are under observance of the following standards or standards documents:

- EN 1127-1
- EN 13463-1
- EN 13463-5

Marking

CE II 2 G c IIB T6 • T_{amb}: -20°C ÷ + 60°C • T_{max. fluid}: 60°C
Tech. File: OMEGA/ATX /08
Technical dossier kept on file c/o: INERIS (0080)

Calolziocorte- LC

Signatura (LARIUS)



Appareil non électrique destiné à être utilisé en atmosphères explosibles
Non electrical equipment intended for use in potentially explosive atmospheres
Apparecchi destinati ad essere utilizzati in atmosfera potenzialmente esplosiva

Directive 2014/34/UE
Directive 2014/34/EU / Direttiva 2014/34/UE

ACCUSÉ DE RECEPTION D'UN DOSSIER TECHNIQUE
ACKNOWLEDGE RECEIPT OF TECHNICAL DOCUMENTATION
AVVISO DI RICEVIMENTO DEL FASCICOLO TECNICO

Appareil / Equipment / Apparecchiatura :

PNEUMATIC TRANSFER & EXTRUSION PUMPS

Type(s) / Type(s) / Tipo(i) : **Séries OMEGA**

Marquage / Marking / Marcatura :



Dépositaire / Applicant / Richiedente :

LARIUS S.r.l.
Via Stoppani, 21

I- 23801 Calolziocorte (LC)

L'INERIS, organisme notifié et identifié sous le numéro 0080, conformément aux articles 17 et 21 de la Directive du Conseil 2014/34/UE du 26 février 2014, accuse réception du dossier conformément à la procédure décrite au chapitre 3, article 13 1) b) ii) de la Directive.

INERIS, notified body and identified under number 0080, in accordance with articles 17 and 21 of Council Directive 2014/34/EU of the 26 february 2014, acknowledges receipt of file according to the procedure described chapter 3, article 13 1) b) ii) of the Directive.

L'INERIS, organismo notificato e identificato con il n.0080 conformemente agli articoli 17 e 21 della Direttiva 2014/34/UE del Consiglio dell'Unione Europea del 26 febbraio 2014, conferma il ricevimento del fascicolo in conformità alla procedura prevista nella rubrica 3, articolo 13 1) b) ii) della Direttiva.

La documentation technique référencée : OMEGA/ATX/08 dated 2008-12-15 est consignée sous le numéro d'enregistrement :

n° INERIS-EQEN 021758.09.

Dans le cadre de cet enregistrement, l'INERIS n'a pas examiné le contenu de la documentation technique.

Date de fin de validité : **2029.03.11**

The technical documentation referenced : OMEGA/ATX/08 dated 2008-12-15 is consigned under the reference :

no INERIS-EQEN 021758.09.

Within the scope of the recording, INERIS did not examine the content of the technical documentation.

Validity completion date : **2029.03.11**

La documentazione tecnica di riferimento : OMEGA/ATX/08 dated 2008-12-15 è depositata con il numero di registrazione :

n° INERIS-EQEN 021758/09.

Nel quadro di questa registrazione, INERIS non ha esaminato il contenuto della documentazione tecnica.

Data di fine di validità : **2029.03.11**

Verneuil-en-Halatte, le 2019.03.11



Le Directeur Général de l'INERIS,
Par délégation,

Thierry HOUEIX
The Chief Executive Officer of INERIS,
Délégué Certification ATEX Ex Certification Office, by delegation,

Il Direttore generale dell' INERIS,
Per Delega,

Ce document ne peut être reproduit que dans son intégralité / Only the entire document may be reprinted / Questo documento può essere riprodotto solo integralmente

Parc Technologique Alata BP 2 F-60550 Verneuil-en-Halatte
 tél +33(0)3 44 55 66 77 fax +33(0)3 44 55 66 99 internet www.ineris.fr

Institut national de l'environnement industriel et des risques

Etablissement public à caractère industriel et commercial - RCS Compiègne B 381 984 924 - Siret 381 984 921 00019 - APE 7120B - TVA Intracom FR 73 381 984 921

IM-1-02/2016 - Mise en application : 20/04/2016



CE DECLARATION OF CONFORMITY



Company



LARIUS srl
Via Antonio Stoppani 21 - 23801 Calolziocorte (LC) ITALY
Tel: +39 0341 621152
Fax: +39 0341 621243
E-mail: larius@larius.com

Declares under his owns responsibility that the product:

OMEGA 40:1 EXT V2 **Airless pneumatic pump for extrusion**

complies with the directives: | - EC Directive 2006/42 Machinery Directive

furthermore to the harmonized standards: | - UNI EN ISO 12100-1/-2
Machinery safety, basic concepts, general principles of design. Basic terminology, methodology. Technical principles.

This declaration relates exclusively to the product in the state in which it was placed on the market, and excludes components or modifications which are added or carried out subsequently by end user.

Signature

Pierangelo Castagna
Managing Director

Calolziocorte, 16 September 2020
Location / Date



**SAMOA INDUSTRIAL, S.A. - HEADQUARTERS
SPAIN AND EXPORT MARKETS**
POL. IND. PORCEYO, I-14 - CAMINO DEL FONTÁN, 831
E-33392 GIJÓN (ASTURIAS), SPAIN
TEL.: +34 985 381 488 - FAX: + 34 985 147 213

**SAMOA S.A.R.L.
FRANCE**
P.A.E.I. DU GIESSEN
3, RUE DE BRISCHBACH
67750 SCHERWILLER, FRANCE
TEL.: +33 3 88 82 79 62 - FAX: +33 3 88 82 77 88

**SAMOA ITALIA - LARIUS
ITALY**
VIA ANTONIO STOPPANI,21
23801 CALOLZIOCORTE (LC) ITALY
Tel.: +39 0341 621152 - Fax: + 39 0341 621242

SAMOA FLOWTECH GMBH
GERMANY, AUSTRIA, SWITZERLAND, THE NETHERLANDS AND GREECE
AM OBEREICHHOLZ 4
D - 97828 MARKTHEIDENFELD, GERMANY
TEL.: +49 9391 9826 0 - FAX: +49 9391 98 26 50



**SAMOA LTD.
UNITED KINGDOM AND REP. OF IRELAND**
ASTURIAS HOUSE - BARRS FOLD ROAD
WINGATES INDUSTRIAL PARK
WESTHOUGHTON, BL5 3XP, UK
TEL.: +44 1942 850600 - FAX: +44 1942 812160

SAMOA CORPORATION
USA AND CANADA
90 MONTICELLO ROAD
WEAVERVILLE, NC 28787, USA
TEL. +1 (828) 645-2290 - FAX: +1 (828) 658 0840



©Copyright, SAMOA INDUSTRIAL, S.A.
SAMOA Industrial, S.A. is an ISO 9001, ISO 14001 and ISO 45001 certified company.

»»» Contact us today!
Visit www.samoaindustrial.com for more information.

INSTRUCTION MANUAL AVAILABLE IN:		
	IT	https://www.larius.com/wp-content/uploads/OMEGA_40_1_EXT_I.pdf
	EN	https://www.larius.com/wp-content/uploads/OMEGA_40_1_EXT_GB.pdf
	DE	https://www.larius.com/wp-content/uploads/OMEGA_40_1_EXT_DE.pdf