



www.larius.com

MIRO¹

Electric diaphragm pump



IT	https://www.larius.com/wp-content/uploads/MIRO_I.pdf
EN	https://www.larius.com/wp-content/uploads/MIRO_GB.pdf
DE	https://www.larius.com/wp-content/uploads/MIRO_D.pdf
FR	https://www.larius.com/wp-content/uploads/MIRO_F.pdf
ES	https://www.larius.com/wp-content/uploads/MIRO_E.pdf
PL	https://www.larius.com/wp-content/uploads/MIRO_PL.pdf
PT	https://www.larius.com/wp-content/uploads/MIRO_P.pdf



This manual is to be considered as an English language translation of the original manual in Italian. The manufacturer shall bear no responsibility for any damages or inconveniences that may arise due to the incorrect translation of the instructions contained within the original manual in Italian.

Due to a constant product improvement programme, the factory reserves the right to modify technical details mentioned in this manual without prior notice.

MIRO'

Electric diaphragm pump

INDEX



















A	WARNING.....	2
B	WORKING PRINCIPLE.....	3
C	TECHNICAL DATA.....	4
D	DESCRIPTION OF THE EQUIPMENT	5
E	TRANSPORT AND UNPACKING.....	7
F	CONDITIONS OF GUARANTEE	7
G	SAFETY RULES.....	7
H	SETTING-UP	8
I	WORKING	11
J	CLEANING AT THE END WORK	12
K	ROUTINE MAINTENANCE	14
L	PROBLEMS AND SOLUTIONS	18
M	CORRECT PROCEDURE OF DECOMPRESSION	19
N	SPARE PARTS	
	COMPLETE HYDRAULIC BODY.....	22
O	COMPLETE COLOUR BODY	24
P	VERTICAL SUCTION SYSTEM.....	26
Q	HORIZONTAL SUCTION SYSTEM	28
R	TROLLEY ASSEMBLY	30
S	COMPLETE PETROL ENGINE CASING.....	33
	DECLARATION OF CONFORMITY.....	33

**WE ADVISE THE USE OF THIS EQUIPMENT ONLY BY PROFESSIONAL OPERATORS.
 ONLY USE THIS MACHINE FOR USAGE SPECIFICALLY MENTIONED IN THIS MANUAL.**

Thank you for choosing a **SAMOA** product.
 As well as the product purchased, you will receive a range of support services
 enabling you to achieve the results desired, quickly and professionally.

A WARNINGS

The table below provides the meaning of the symbols used in this manual in relation to using, earthing, operating, maintaining, and repairing of this equipment.

	<ul style="list-style-type: none"> • Read this operator's manual carefully before using the equipment. • An improper use of this machine can cause injuries to people or things. • Do not use this machine when under the influence of drugs or alcohol. • Do not modify the equipment under any circumstances. • Use products and solvents that are compatible with the various parts of the equipment, and read the manufacturer's warnings carefully. • See the Technical Details for the equipment given in the Manual. • Check the equipment for worn parts once a day. If any worn parts are found, replace them using ONLY original spare parts. • Keep children and animals away from work area. • Comply with all safety standards.
	<ul style="list-style-type: none"> • It indicates an accident risk or serious damage to equipment if this warning is not followed.
   	<p>FIRE AND EXPLOSION HAZARD</p> <ul style="list-style-type: none"> • Solvent and paint fumes in work area can ignite or explode. • To help prevent fire and explosion: <ul style="list-style-type: none"> - Use equipment ONLY in well ventilated area. - Eliminate all ignition sources, such as pilot lights, cigarettes and plastic drop cloths (potential static arc). - Ground equipment and conductive objects. - Use only grounded hoses. - Do not use trichloroethane, methylene chloride, other halogenated hydrocarbon solvents or fluids containing such solvents in pressurized aluminium equipment. Such use can cause serious chemical reaction and equipment rupture, and result in death, serious injury, and property damage. - Do not form connections or switch light switches on or off if the air contains inflammable fumes. • If electrical shocks or discharges are encountered the operation being carried out using the equipment must be stopped immediately. • Keep a fire extinguisher at hand in the immediate vicinity of the work area.
	<ul style="list-style-type: none"> • It indicates wound and finger squashing risk due to movable parts in the equipment. • Tenersi lontano dalle parti in movimento. • Do not use the equipment without the proper protection. • Before any inspection or maintenance of the equipment, carry out the decompression procedure explained in this manual, and prevent any risk of the equipment starting unexpectedly.
 	<ul style="list-style-type: none"> • Report any risk of chemical reaction or explosion if this warning has not been given. • (IF PROVIDED) There is a risk of injury or serious lesion related to contact with the jet from the spray gun. If this should occur, IMMEDIATELY contact a doctor, indicating the type of product injected. • (IF PROVIDED) Do not spray before the guard has been placed over the nozzle and the trigger on the spray gun. • (IF PROVIDED) Do not put your fingers in the spray gun nozzle. • Once work has been completed, before carrying out any maintenance, complete the decompression procedure.
	<ul style="list-style-type: none"> • It indicates important recommendations about disposal and recycling process of products in accordance with the environmental regulations.
    	<ul style="list-style-type: none"> • Mark any clamps attached to earth cables. • Use ONLY 3-wire extension cords and grounded electrical outlets. • Before starting work make sure that the electrical system is grounded and that it complies with safety standards. • High-pressure fluid from gun, hose leaks, or ruptured components will pierce skin. • To help prevent injection, always: <ul style="list-style-type: none"> - (IF PROVIDED) Engage trigger lock when not spraying. - (IF PROVIDED) Do not put your hand over the spray tip. Do not stop or deflect leaks with your hand, body or other. - (IF PROVIDED) Do not point gun at anyone or at any part of the body. - (IF PROVIDED) Never spray without tip guard. - Do pressure relief if you stop spraying or being servicing sprayer and before any maintenance operations. - Do not use components rated less than sprayer Maximum Working Pressure. - Never allow children to use this unit - (IF PROVIDED) Brace yourself; gun may recoil when triggered. • If high pressure fluid pierces your skin, the injury might look like "just a cut", but it is a serious wound! Get immediate medical attention.
   	<ul style="list-style-type: none"> • It is obligatory to wear suitable clothing as gloves, goggles and face shield. • Wear clothing that complies with the safety standards in force in the country in which the equipment is used. • Do not wear bracelets, earrings, rings, chains, or anything else that may hinder the operator's work. • Do not wear clothing with wide sleeves, scarves, ties, or any other piece of clothing that could get tangled up in moving parts of the equipment during the work, inspection, or maintenance cycles.

B WORKING PRINCIPLE

The **MIRO[®]** unit is defined as an “electric diaphragm pump”. An electric diaphragm pump is used for high pressure paint spraying without air (*known as “airless”*).

The pump is powered by an electric (*internal combustion*) motor coupled with a cam shaft. The shaft acts on the hydraulic piston as it pumps oil from the hydraulic case and sends the suction diaphragm into fibrillation. When the diaphragm moves, it creates a vacuum. The product is sucked up, pushed towards the pump outlet and sent to the guns through the flexible hose. A hydraulic valve on the hydraulic case head allows setting and checking the pressure of the paint product at the pump outlet. A second hydraulic safety valve to avoid over-pressure, ensures total equipment reliability.

The hydraulic box allows to convert the vertical gravity hopper version (1) to horizontal suction version (2).



Fig. 1

	COD.	SUCTION SYSTEM 6 LITRES TANK	MOTOR	FITTING	HOSE	GUN
TROLLEY	K21501/1	Suction system	220V	1/4"	Cod. 18017	Cod. 11250
	21500/1	Suction system	220 V	1/4"	-	-
	K21503/1	Suction system	110 V	1/4"	Cod. 18017	Cod. 11250
	21502/1	Suction system	110 V	1/4"	-	-
	K21507/1	6l	220 V	1/4"	Cod. 18017	Cod. 11250
	21506/1	6l	220 V	1/4"	-	-
	K21509/1	6l	110 V	1/4"	Cod. 18017	Cod. 11250
	21508/1	6l	110 V	1/4"	-	-
FRAME	K21561/1	Suction system	220V	1/4"	Cod. 18017	Cod. 11250
	21560/1	Suction system	220 V	1/4"	-	-
	K21565/1	6l	220V	1/4"	Cod. 18017	Cod. 11250
	21564/1	6l	220 V	1/4"	-	-

Fields of application	Application materials	
Indoor	Lacquer	Paints
Outdoor	Waterborne	Emulsions
Industrial buildings	Acrylic	Fillers
Industrial constructions	Primers	Rust preventer
Redeveloping	Enamels	Primer
Roofing	Fixative	

C TECHNICAL DATA

	MIRO'
Version	Trolley - Frame
Max. delivery	2,2 l/m
Max. working pressure	220 bar
Motor power	0,75 Kw
Voltage	115 VAC (60Hz)
	220 VAC (50Hz)
	380 VAC (50Hz)
Weight	20 Kg - frame/ 23 Kg - trolley
Max. nozzle size	0,019"
Power generation	3 Kw single phase
Material outlet	1/4" (M)
Livello pressione sonora	≤ 65dB (A)
Length	(A) 400 mm
Width	(B) 400 mm
Height	(C) 900 mm

Parts of the pump in contact with the material: Stainless Steel AISI 420B, PTFE, Aluminium.



Fig. 1



Fig. 2

D DESCRIPTION OF THE EQUIPMENT

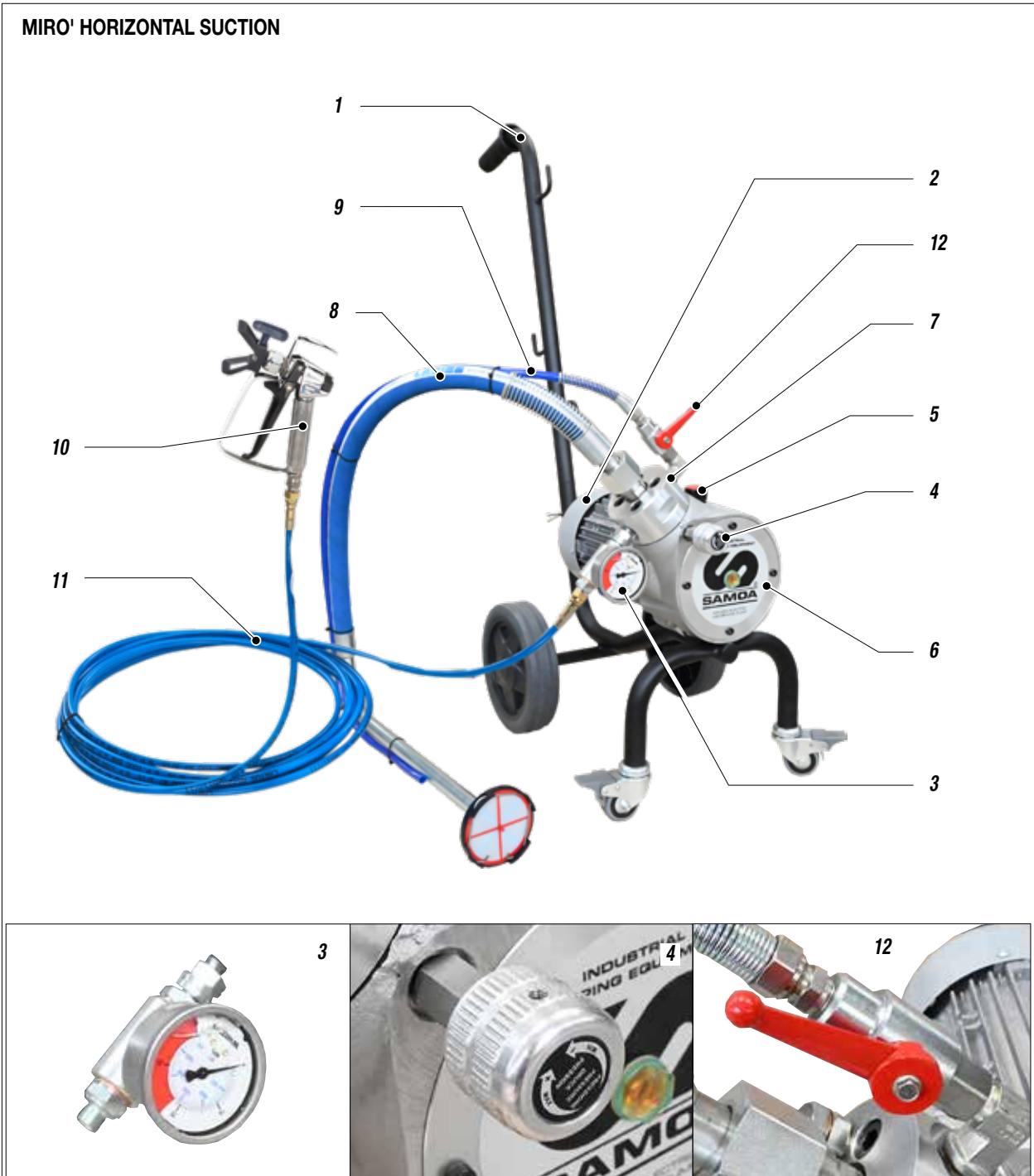

Fig. 1

Pos.	Description
1	Carriage
2	Electric / combustion motor
3	High pressure manometer
4	Setting valve
5	Hydraulic oil filling cap
6	Hydraulic body

Pos.	Description
7	Colour body
8	Suction tube
9	Recirculation tube
10	LARIUS AT 250 gun
11	High pressure feed tube
12	Circulation tap

MIRO' VERTICAL SUCTION

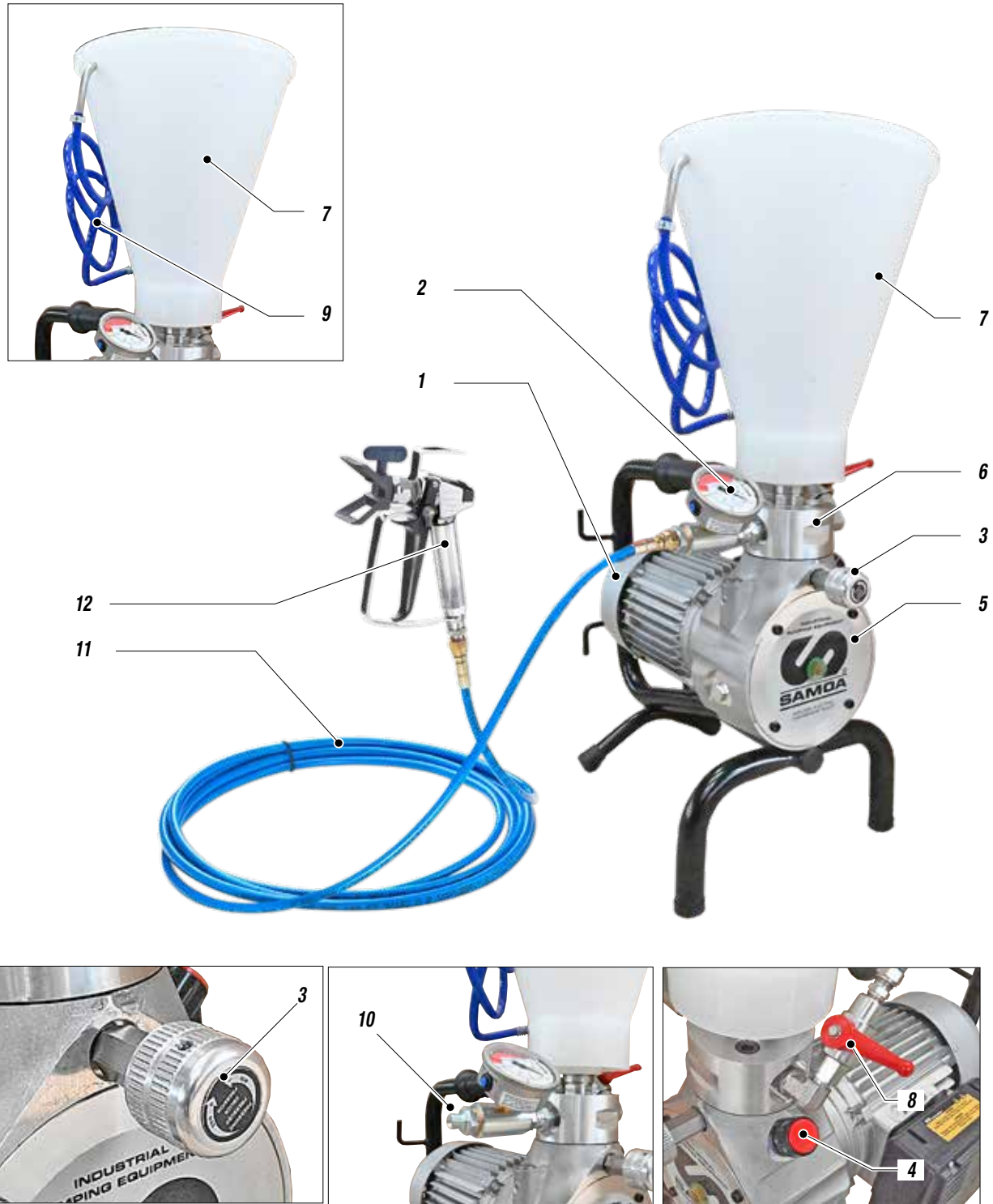

Fig. 2

Pos.	Description
1	Electric / combustion motor
2	High pressure manometer
3	Setting valve
4	Hydraulic oil filling cap
5	Hydraulic body
6	Colour body

Pos.	Description
7	Tank
8	Circulation tap
9	Recirculation tube
10	Feed tube connection
11	Feed tube
12	LARIUS AT 250 gun

E TRANSPORT AND UNPACKING

- The packed parts should be handled as indicated in the symbols and markings on the outside of the packing.
- Before installing the equipment, ensure that the area to be used is large enough for such purposes, is properly lit and has a clean, smooth floor surface.
- The user is responsible for the operations of unloading and handling and should use the maximum care so as not to damage the individual parts or injure anyone.
To perform the unloading operation, use only qualified and trained personnel (truck and crane operators, etc.) and also suitable hoisting equipment for the weight of the installation or its parts.
Follow carefully all the safety rules.
The personnel must be equipped with the necessary safety clothing.
- The manufacturer will not be responsible for the unloading operations and transport to the workplace of the machine.
- Check the packing is undamaged on receipt of the equipment. Unpack the machine and verify if there has been any damage due to transportation.
In case of damage, call immediately the manufacturer and the Shipping Agent. All the notices about possible damage or anomalies must arrive timely within 8 days at least from the date of receipt of the plant through Registered Letter to the Shipping Agent and to **the manufacturer**.



The disposal of packaging materials is a customer's competence and must be performed in accordance with the regulations in force in the country where the plant is installed and used. It is nevertheless sound practice to recycle packaging materials in an environment-friendly manner as much as possible.

F CONDITIONS OF GUARANTEE



The conditions of guarantee do not apply in the following situations:

- improper washing and cleaning of components causing malfunction, wear or damage to the equipment or any of its parts;
- improper use of the equipment;
- use that does not conform with applicable national legislation;
- incorrect or faulty installation;
- modifications, interventions and maintenance that have not been authorised by the manufacturer;
- use of non-original spare parts or parts that do not correspond to the specific model;
- total or partial non-compliance with the instructions provided.

G SAFETY RULES

- THE EMPLOYER SHALL TRAIN ITS EMPLOYEES ABOUT ALL THOSE RISKS STEMMING FROM ACCIDENTS, ABOUT THE USE OF SAFETY DEVICES FOR THEIR OWN SAFETY AND ABOUT THE GENERAL RULES FOR ACCIDENT PREVENTION IN COMPLIANCE WITH INTERNATIONAL REGULATIONS AND WITH THE LAWS OF THE COUNTRY WHERE THE PLANT IS USED.
- THE BEHAVIOUR OF THE EMPLOYEES SHALL STRICTLY COMPLY WITH THE ACCIDENT PREVENTION AND ALSO ENVIRONMENTAL REGULATIONS IN FORCE IN THE COUNTRY WHERE THE PLANT IS INSTALLED AND USED.



Read carefully and entirely the following instructions before using the product.

Please save these instructions in a safe place.

The unauthorised tampering/replacement of one or more parts composing the machine, the use of accessories, tools, expendable materials other than those recommended by the manufacturer can be a danger of accident.

The manufacturer will be relieved from tort and criminal liability.

- KEEP YOUR WORK PLACE CLEAN AND TIDY. DISORDER WHERE YOU ARE WORKING CREATES A POTENTIAL RISK OF ACCIDENTS.
- ALWAYS KEEP PROPER BALANCE AVOIDING UNUSUAL STANCE.
- BEFORE USING THE TOOL, ENSURE THERE ARE NOT DAMAGED PARTS AND THE MACHINE CAN WORK PROPERLY.
- ALWAYS FOLLOW THE INSTRUCTIONS ABOUT SAFETY AND THE REGULATIONS IN FORCE.
- KEEP THOSE WHO ARE NOT RESPONSIBLE FOR THE EQUIPMENT OUT OF THE WORK AREA.
- **NEVER** EXCEED THE MAXIMUM WORKING PRESSURE INDICATED.
- **NEVER** POINT THE SPRAY GUN AT YOURSELVES OR AT OTHER PEOPLE. THE CONTACT WITH THE CASTING CAN CAUSE SERIOUS INJURIES.
- IN CASE OF INJURIES CAUSED BY THE GUN CASTING, SEEK IMMEDIATE MEDICAL ADVICE SPECIFYING THE TYPE OF THE PRODUCT INJECTED. **NEVER** UNDERVALUE A WOUND CAUSED BY THE INJECTION OF A FLUID.
- ALWAYS DISCONNECT THE SUPPLY AND RELEASE THE PRESSURE IN THE CIRCUIT BEFORE PERFORMING ANY CHECK OR PART REPLACEMENT OF THE EQUIPMENT.
- NEVER MODIFY ANY PART IN THE EQUIPMENT. CHECK REGULARLY THE COMPONENTS OF THE SYSTEM. REPLACE THE PARTS DAMAGED OR WORN.
- TIGHTEN AND CHECK ALL THE FITTINGS FOR CONNEC-

TION BETWEEN PUMP, FLEXIBLE HOSE AND SPRAY GUN BEFORE USING THE EQUIPMENT.

- ALWAYS USE THE FLEXIBLE HOSE SUPPLIED WITH KIT.
- THE USE OF ANY ACCESSORIES OR TOOLING OTHER THAN THOSE RECOMMENDED IN THIS MANUAL, MAY CAUSE DAMAGE OR INJURE THE OPERATOR.
- THE FLUID CONTAINED IN THE FLEXIBLE HOSE CAN BE VERY DANGEROUS. HANDLE THE FLEXIBLE HOSE CAREFULLY. DO NOT PULL THE FLEXIBLE HOSE TO MOVE THE EQUIPMENT. NEVER USE A DAMAGED OR A REPAIRED FLEXIBLE HOSE.
- NEVER SPRAY OVER FLAMMABLE PRODUCTS OR SOLVENTS IN CLOSED PLACES.
- NEVER USE THE TOOLING IN PRESENCE OF POTENTIALLY EXPLOSIVE GAS.



The high speed of travel of the product in the hose can create static electricity through discharges and sparks. It is suggested to earth the equipment. The pump is earthed through the earth cable of the supply. The gun is earthed through the high pressure flexible hose. All the conductors near the work area must be earthed..



Always check the product is compatible with the materials composing the equipment (*pump, spray gun, flexible hose and accessories*) with which it can come into contact. Never use paints or solvents containing Halogen Hydrocarbons (as the *Methylene Chloride*).



If these products come into contact with aluminium parts can provoke dangerous chemical reactions with risk of corrosion and explosion.



If the product to be used is toxic, avoid inhalation and contact by using protection gloves, goggles and proper face shields.



Take proper safety measures for the protection of hearing in case of work near the plant.

Electrical safety precautions

- Check the "ON/OFF" switch is on the "OFF" position before connecting the cable to the mains.
- Never carry a plugged-in equipment.
- Disconnect the equipment before storing it and before performing any maintenance operation or replacing of accessories.

- Do not carry the equipment neither unplug it by pulling the electric cable.
Protect the cable from heat, oil and sharp edges.
- When the tool is used outdoors, use only an extension cable suited for outdoor use and so marked.



Never attempt to tamper with the calibre of instruments.

- Take care when the pumping rod is moving.
Stop the machine whenever someone is within its vicinity.
- Repairs of the electrical equipment should only be carried out by skilled personnel, otherwise considerable danger to the user may result.

H SETTING-UP

CONNECTION OF THE FLEXIBLE HOSE TO THE GUN

- Connect the high pressure flexible hose to the pump and to the gun, ensuring to tighten the fittings (the use of two wrenches is suggested).
Never use sealants on fittings' threads.
- It is recommended to use the hose provided with the standard kit (ref. 35017).
NEVER use a damaged or a repaired flexible hose.

CHECK ON POWER SUPPLY



Make sure that the electrical system is earthed and complies with regulations.

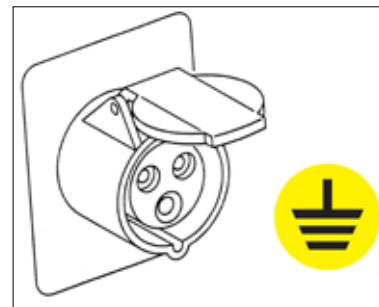

Fig. 1

- The supply cable (2) is provided without plug. Use a plug which guarantees the plant earthing. Only a technician or a skilled person should perform the connection of the plug to the electric cable.

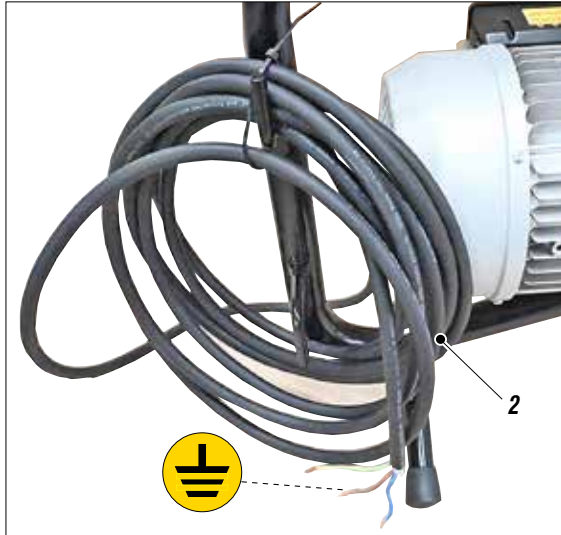

Fig. 2



Should anyone use an extension cable between the tooling and the socket, it must have the same characteristics as the cable supplied (*minimum diameter of the wire 2.5 mm²*) with a maximum length of 50 mt. Higher lengths and lower diameters can provoke excessive voltage falls and also an anomalous working of the equipment.



COLLEGAMENTO DELL'APPARECCHIATURA ALLA LINEA ELETTRICA

- Check the ON/OFF switch (3) is on the "OFF" position (0) before connecting the cable to the mains.

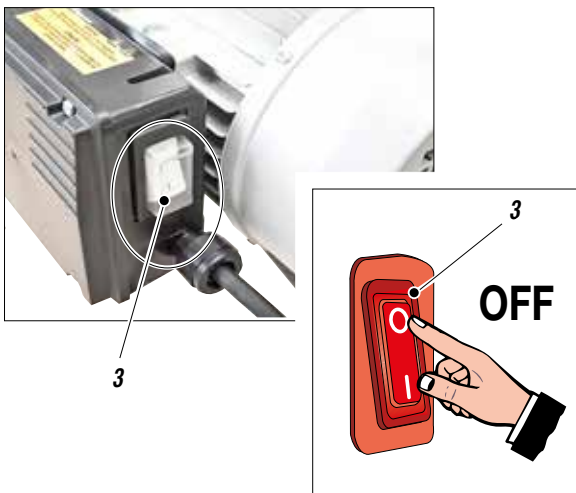

Fig. 3

- Place the pressure control knob (4) on the "MIN" position (turn counterclockwise).

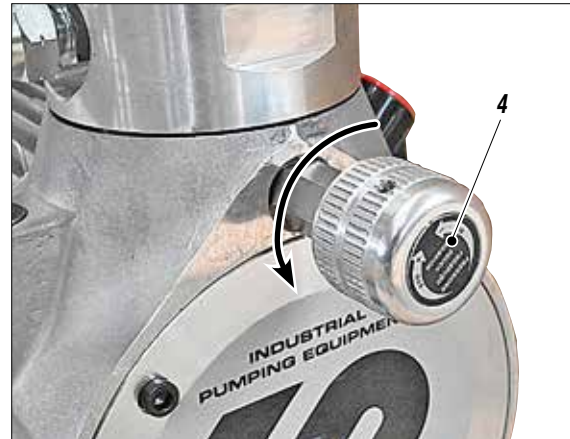

Fig. 4

WASHING OF THE NEW EQUIPMENT

- The equipment has already been adjusted at our factory with light mineral oil left inside the pumping group as protection. Therefore, wash with diluent before sucking the product.
- Lift the suction pipe and dip it into the solvent tank (5).



Fig. 5

- Ensure the gun (6) is without nozzle.



Fig. 6

- Open the re-circulation tap (7).

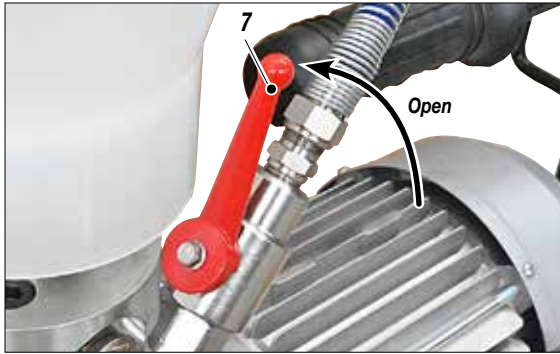

Fig. 7

- Turn the unit ON-OFF switch (3) on the "ON" position (I).

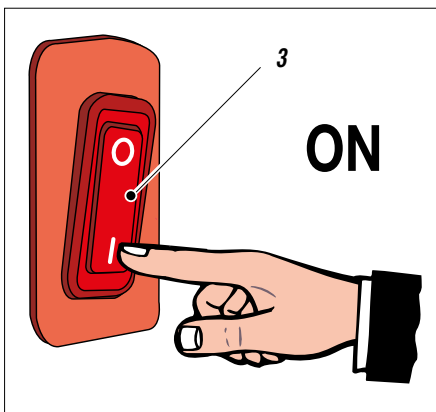

Fig. 8

- Rotate the pressure setting knob (4) slightly clockwise so that the machine operates at minimum power.



Fig. 9

- Point the gun (8) at a container (8) keeping the trigger pressed (so as to drain the oil inside) till a clean solvent comes out. Now, release the trigger.



Fig. 10

- Remove the suction pipe and take away the solvent tank.
- Point the gun at the solvent tank and press the trigger so as to recover the residual solvent.
- As the pump idles, press the ON/OFF switch (3) on the position "OFF" (0) to stop the tooling.

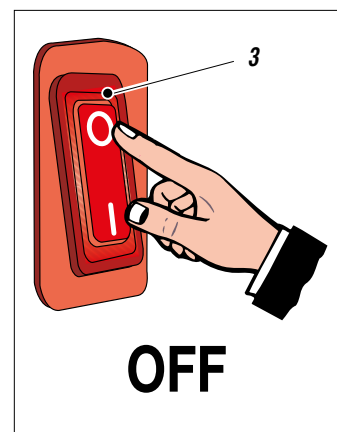

Fig. 11



Absolutely avoid to spray solvents indoors. In addition, it is recommended to keep away from the pump in order to avoid the contact between the solvent fumes and the electric motor.

- Now the machine is ready. Should you use water paints, besides the solvent wash, a wash with soapy and then clean water is suggested.
- Insert the gun trigger lock and assemble the nozzle.

PREPARATION OF THE PAINT

- Make sure the product is suitable to be used with a spray gun.
- Mix and filter the product before using it. For filtration, use **CLOSE-MESH (ref.214)** and **LARGE-MESH (ref.215) LARIUS METEX** braids.



Make sure the product to be used is compatible with the materials employed for manufacturing the equipment (*stainless steel and aluminium*). Because of that, please contact the supplier of the product.

Never use products containing halogen hydrocarbons (as *methylene chloride*). If these products come into contact with aluminium parts of the equipment, can provoke dangerous chemical reactions with risk of explosion.

I WORKING



Use power units with asynchronous alternator.

START OF THE PAINTING OPERATIONS

- Use the tooling after performing all the **SETTING UP** operations above described.
- Dip the suction pipe (1) into the product tank.



Fig. 1

- Open the re-circulation tap (2).
- Press the ON/OFF switch of the equipment and turn a little the pressure control knob (3) clockwise, so as the machine works at the idle speed.
- Make sure the product recycles from the return tube (4).
- Close the re-circulation tap (2).

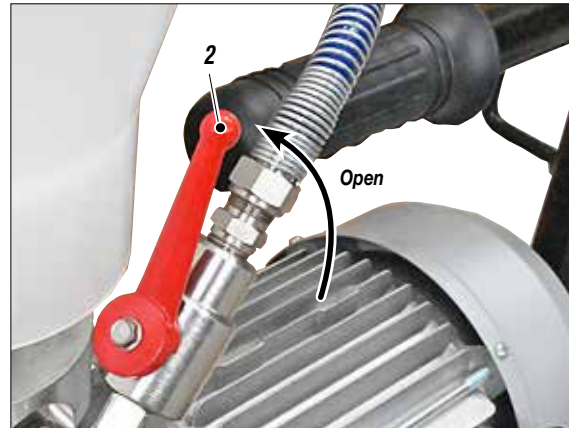

Fig. 2

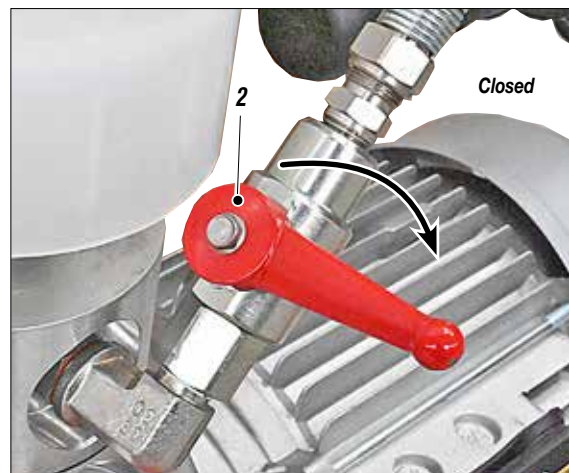

Fig. 3

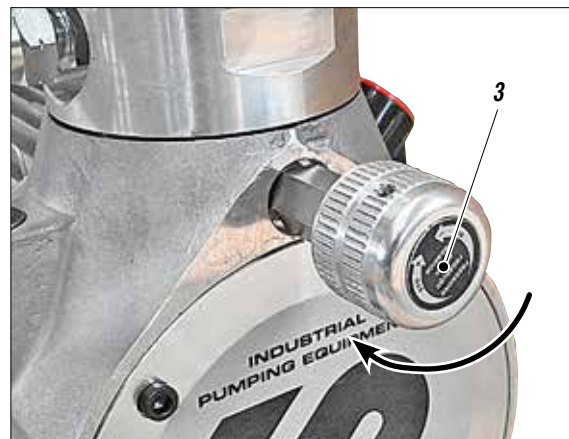

Fig. 4



Fig. 5

- At this point the machine will continue to suck the paint product until the delivery hose is completely full. Afterwards, the product will re-circulate automatically.

SPRAY ADJUSTMENT

- Slowly turn clockwise the pressure control knob to reach the pressure value in order to ensure a good atomization of the product.
- An irregular and marked spray on the sides indicates a low working pressure. On the contrary, a too high pressure causes a high fog (*overspray*) and waste of product..
- In order to avoid overthickness of paint, let the gun advance sideways (*right-left*) when spraying.
- Always paint with regular parallel bands coats.
- Keep a safety and constant distance between the gun and the support to be painted and also keep yourselves perpendicular to it.



NEVER point the spray gun at yourselves or at other people. The contact with the casting can use serious injuries. In case of injuries caused by the gun casting, seek immediate medical advice specifying the type of the product injected.



J CLEANING AT THE END WORK

- Reduce pressure to the minimum (*turn counterclockwise the pressure control knob (1)*).

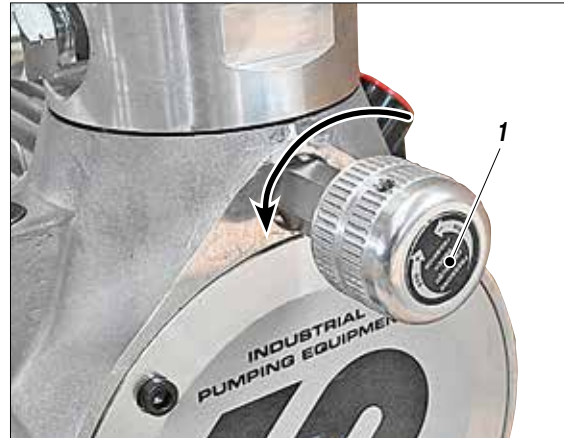

Fig. 1

- Press the ON/OFF switch (2) placed on the box of the electric motor, to stop the equipment.

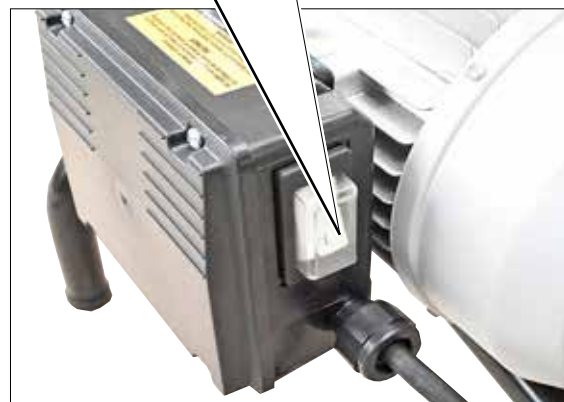
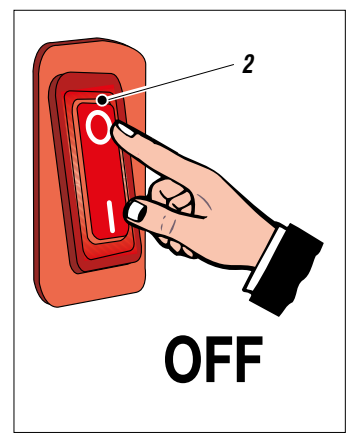

Fig. 2

- First release the residual pressure from the gun by holding it pointed down towards the paint container, then open the re-circulation tap (3).

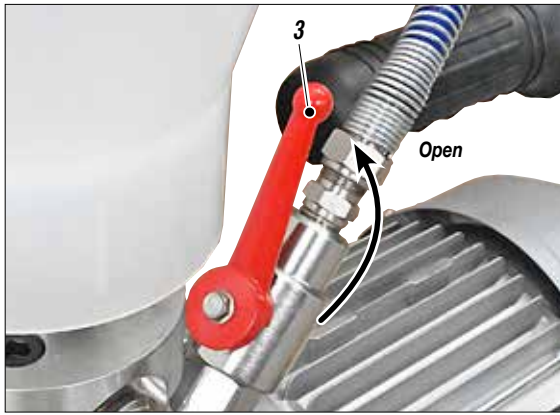

Fig. 3



For the horizontal version, lift the suction hose and replace the bucket containing the product with a bucket of solvent (make sure it is compatible with the product you are using).

- Unscrew the gun nozzle (do not forget to clean it with solvent).
- Turn the ON-OFF switch (2) on the ON position and rotate the pressure setting knob (1) slightly clockwise.
- Make sure the solvent recycles the washing fluid from the return tube (4).



Fig. 4

- Chiudere il rubinetto di ricircolo (3).



Fig. 5

- Point the gun (5) at the product tank (6) and, keeping the trigger pressed, release the remaining product till a clean solvent comes out. Now, release the trigger.

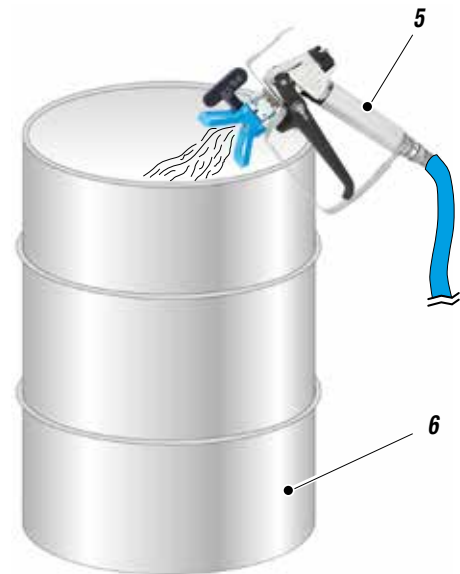

Fig. 6

- Lift again the suction pipe and remove the solvent tank.
- Now point the gun at the solvent tank and press the trigger so as to recover the residual solvent.
- As the pump starts idling, press the ON/OFF switch (2) su OFF (0) to stop the equipment.

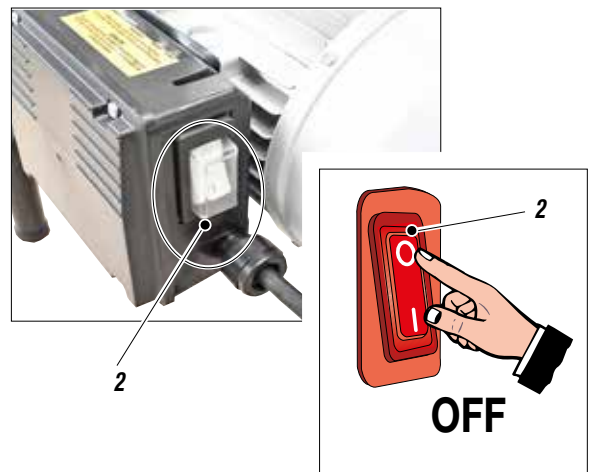

Fig. 7

- In case of long storage, we recommend you to suck and to leave light mineral oil inside the pumping group and the flexible hose.



Follow the washing procedure before using again the equipment.

K ROUTINE MAINTENANCE

RIPRISTINO OLIO IDRAULICO

With each start up, check the hydraulic oil level by looking through the gauge (1) on the side of the hydraulic body. If necessary, use to top up the level:

**AGIP DICREA 150 type hidraulic oil
0,7 LT**



Fig. 1

RELEASE THE SUCTION VALVE

If the pump malfunctions, release the suction valve fitted on the head of the pump in the following way:

- Remove the suction hose fitting (*Mirò horizontal version*) or the suction tank (*Mirò vertical version*) and release the valve by inserting a rigid rod (2) with a diameter of no more than 15 mm.



To facilitate this operation add a few drops of oil.

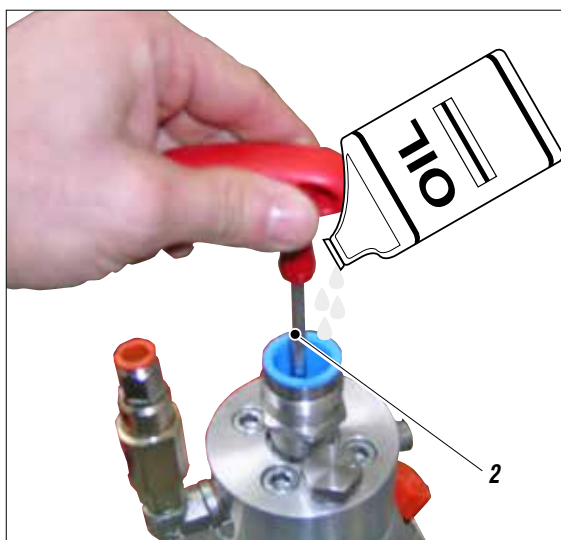

Fig. 2

CLEANING THE COMPRESSION VALVE

If the machine has problems with sucking up the liquid, disassemble the compression valve (3), and clean it with solvents that are specifically for the type of paint being used.



Fig. 3

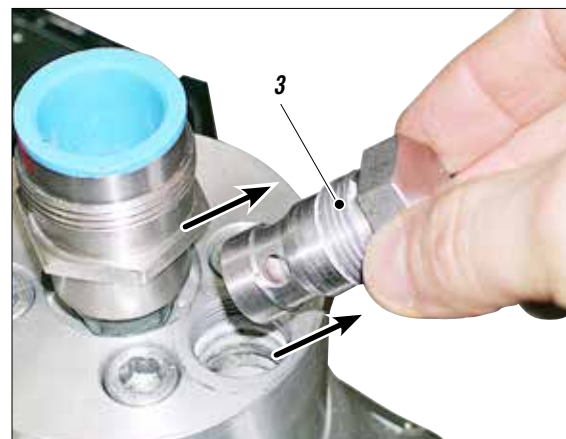

Fig. 4

Once it has been cleaned, shake the valve (3) by hand to check that the ball inside moves freely in its seating. If necessary, clean again.

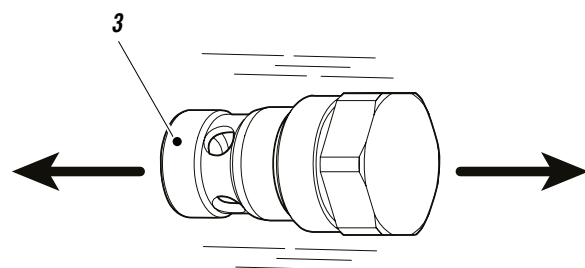

Fig. 5

Check that the ball seals in its seating as follows:

- Turn the valve (3) upside down;

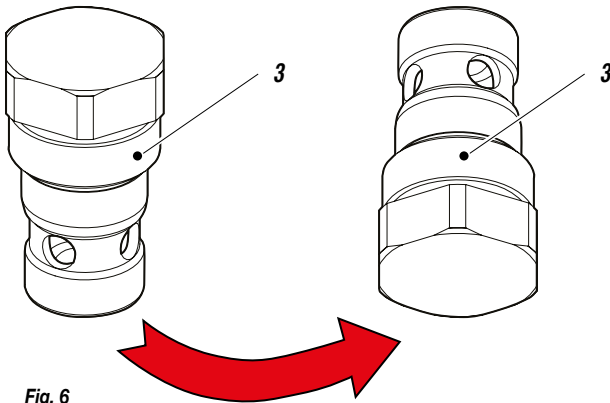

Fig. 6

- Put solvent into the groove in the ball's seating;

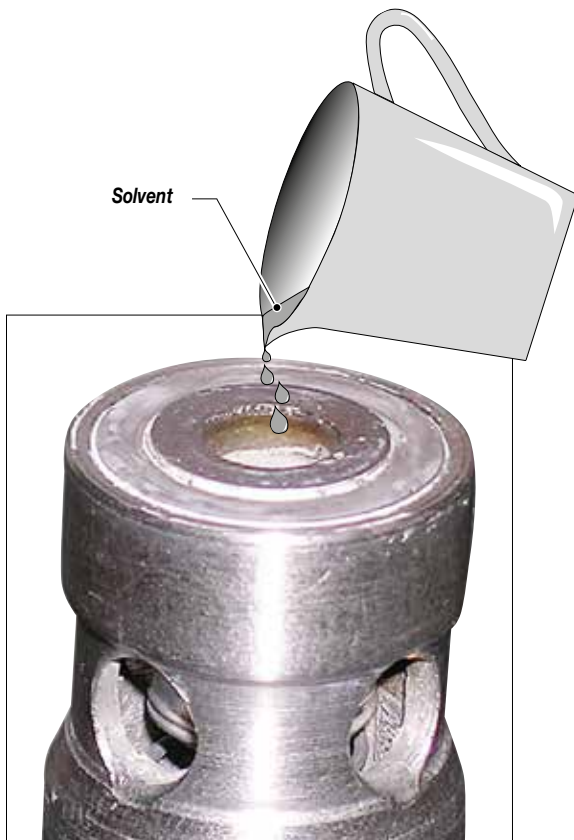

Fig. 7

- If the quantity of solvent a few minutes later is still identical to that added previously, the ball's seal in its seating is ensured;

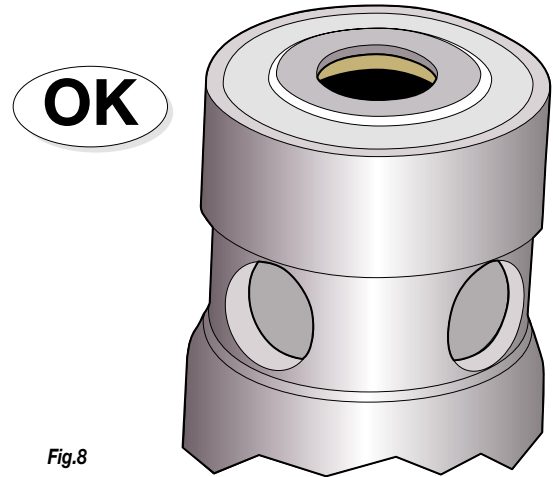

Fig.8

- If the solvent flows out the holes at the bottom within a few minutes, replace this valve with a new one;

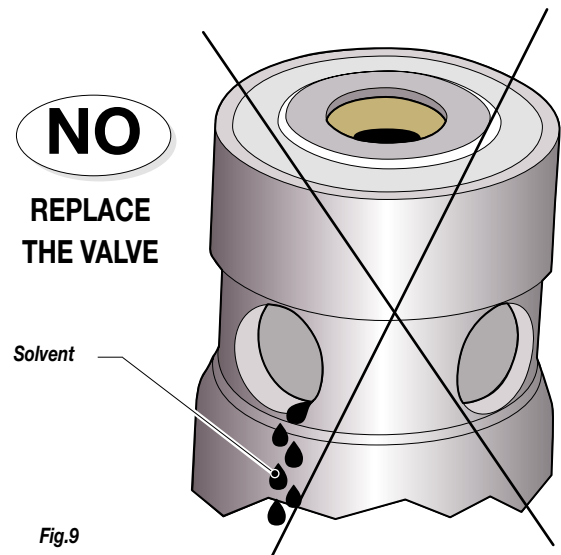

Fig.9

- Once the valve (3) is properly clean, fit it again.



Fig.10

REPLACING HYDRAULIC OIL

After operating for 100 hours, replace the oil in the pump;

- Discharge the waste oil through the plug (4) fitted at the bottom of the pump casing.
- Clean the seals on the cap and replace it if worn.
- Remove and clean the filter (5) on the side of the pump casing; if necessary, replace the filter and the respective seals.
- Clean and, if necessary, replace the worn seals (5).
- Replace the plug (4).
- Fill the pump with the recommended oil until it reaches the maximum level.

AGIP DICREA 150 type hidraulic oil

- Then, substitute the oil every 250 hours.



Fig.11



Fig.12

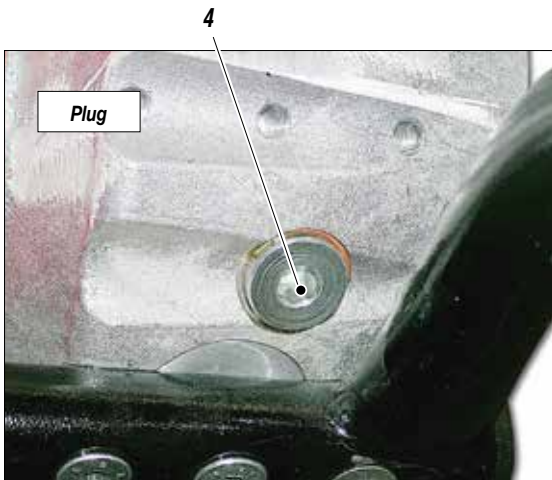
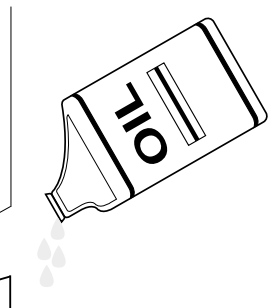

Fig.13

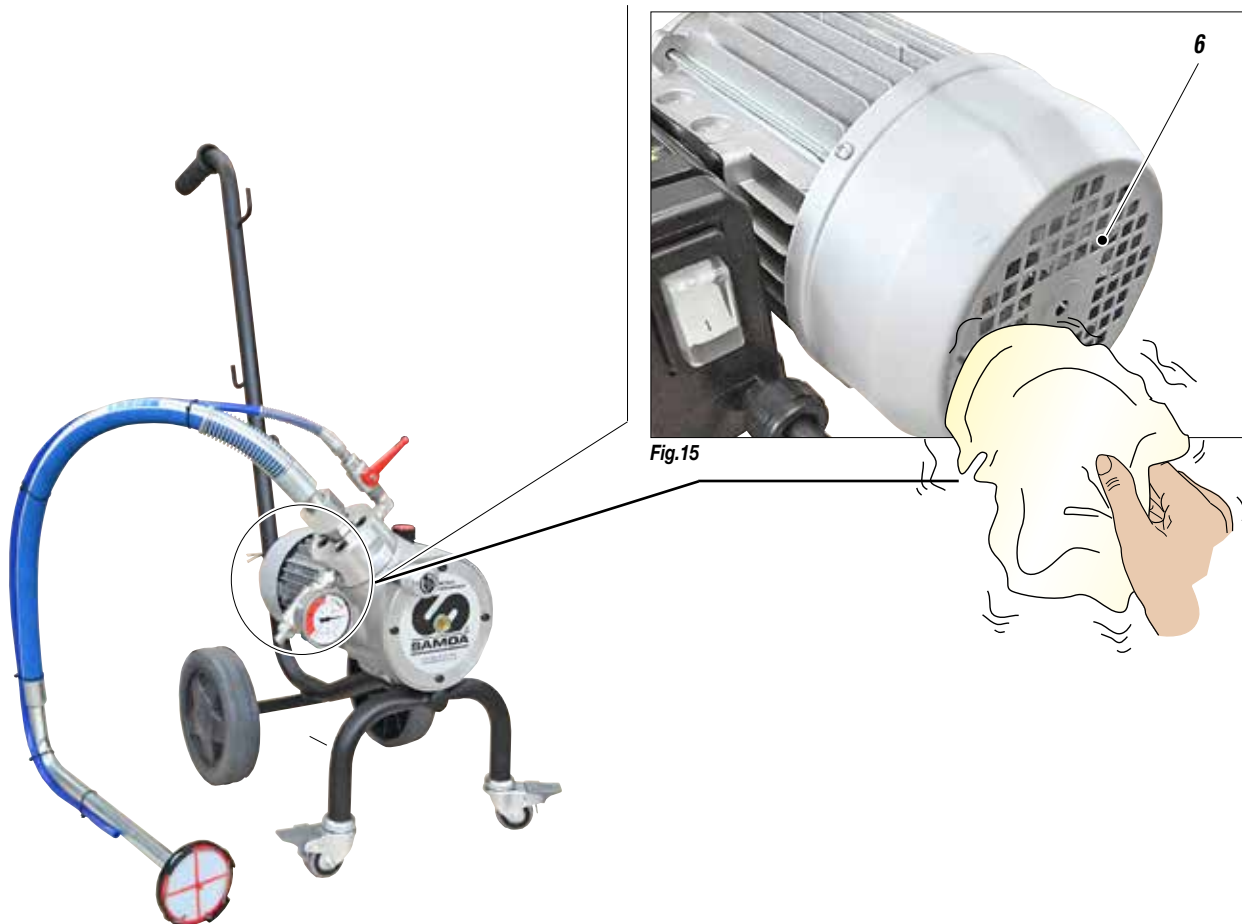

Fig.14



CLEANING THE MOTOR COOLING FAN GUARD

Clean the motor cooling fan protection guard (6) and the finned motor casing periodically to ensure the maximum cooling.



L PROBLEMS AND SOLUTIONS

Problem	Cause	Solution
The equipment does not start	Lack of voltage;	Check the correct connection to the power supply;
	Considerable drops in mains voltage;	Check the extension cable;
	ON-OFF switch disconnected;	Ensure the ON-OFF switch is on the "ON" position and turn clockwise the pressure control knob;
	Breakdown of motor electric control box;	Verify and replace it, if necessary;
	The product is solidified inside the pump;	Open the drain valve to release pressure in the circuit and stop the machine. Remove the compression valve and clean it;
The equipment does not suck the product	Suction filter clogged;	Clean or replace it;
	Suction filter too fine;	Replace it with a larger-mesh filter (<i>with very dense products, remove the filter</i>);
	Suction valve dirty;	Disassemble and clear it;
	The equipment sucks air;	Check the suction pipe;
The equipment suck but does not reach the pressure desired	Lack of product;	Add the product;
	The equipment sucks air;	Check the suction pipe;
	The drain valve is open;	Close the drain valve;
	Suction or delivery valve dirty	Disassemble the colour body group
When pressing the trigger, the pressure lowers considerably	Nozzle too big or worn;	Replace it with a smaller one;
	The product is too dense;	Dilute the product, if possible;
	The filter of the gun-but is too fine;	Replace it with a larger-mesh filter
The pressure is normal but the product is not atomized. Leakage from the seal-tightening screw	The nozzle is partially clogged;	Clean or replace it;
	The product is too dense;	Dilute the product, if possible;
	The filter of the gun-but is too fine	Replace it with a larger-mesh filter
The atomization is imperfect	The nozzle is worn;	Replace it;



Always close the air compressed supply and unload the plant pressure before performing any check or replacement of pump parts (see "correct procedure of decompression").

M CORRECT PROCEDURE OF DECOMPRESSION

- Insert the gun clamp (1).

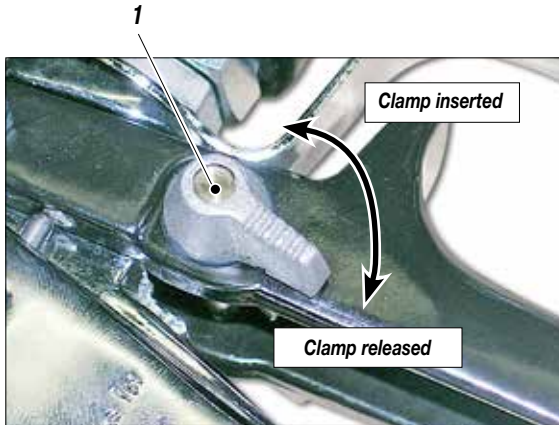

Fig.1

- Move the ON/OFF switch (2) to the **OFF position (0)** to stop the equipment.

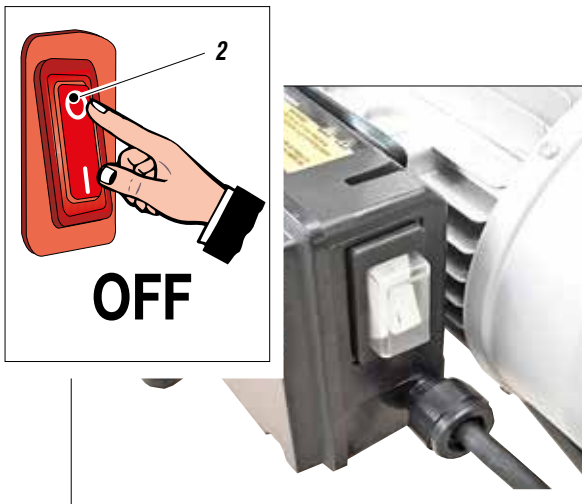

Fig.2

- Set the valve (3) at its minimum pressure setting (*turn anti-clockwise*).



Fig.3

- Disconnect the power supply cable (4).

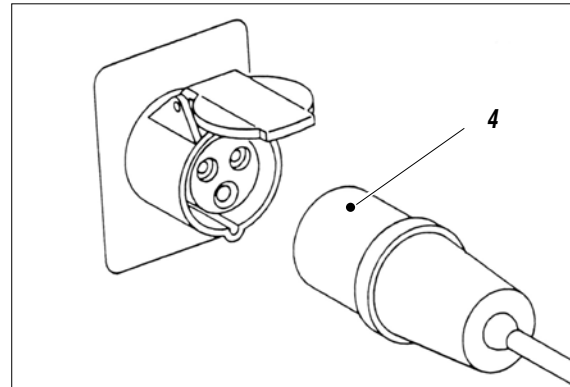

Fig.4

- Release the gun clamp (1). Point the gun at the tank of the product and press the trigger to release pressure. At the end of the operation, insert the gun clamp.
- Open the re-circulation tap (5) to release residual pressure.



Fig.5

WARNING :



If the equipment is still under pressure after performing the operations above described because of the nozzle or the flexible hose clogged, proceed as follows:



- Loosen very slowly the gun nozzle.
- Release the clamp.
- Point the gun at the container of the product and press the trigger to release pressure.
- Loosen very slowly the fitting of connection from the flexible hose to the gun.
- Clean or replace the flexible hose and the nozzle.

Intentionally blank page

SPARE PARTS

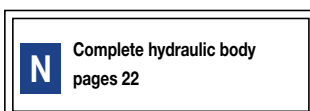
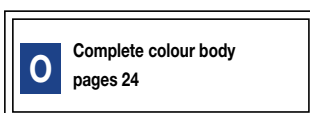
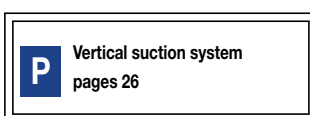
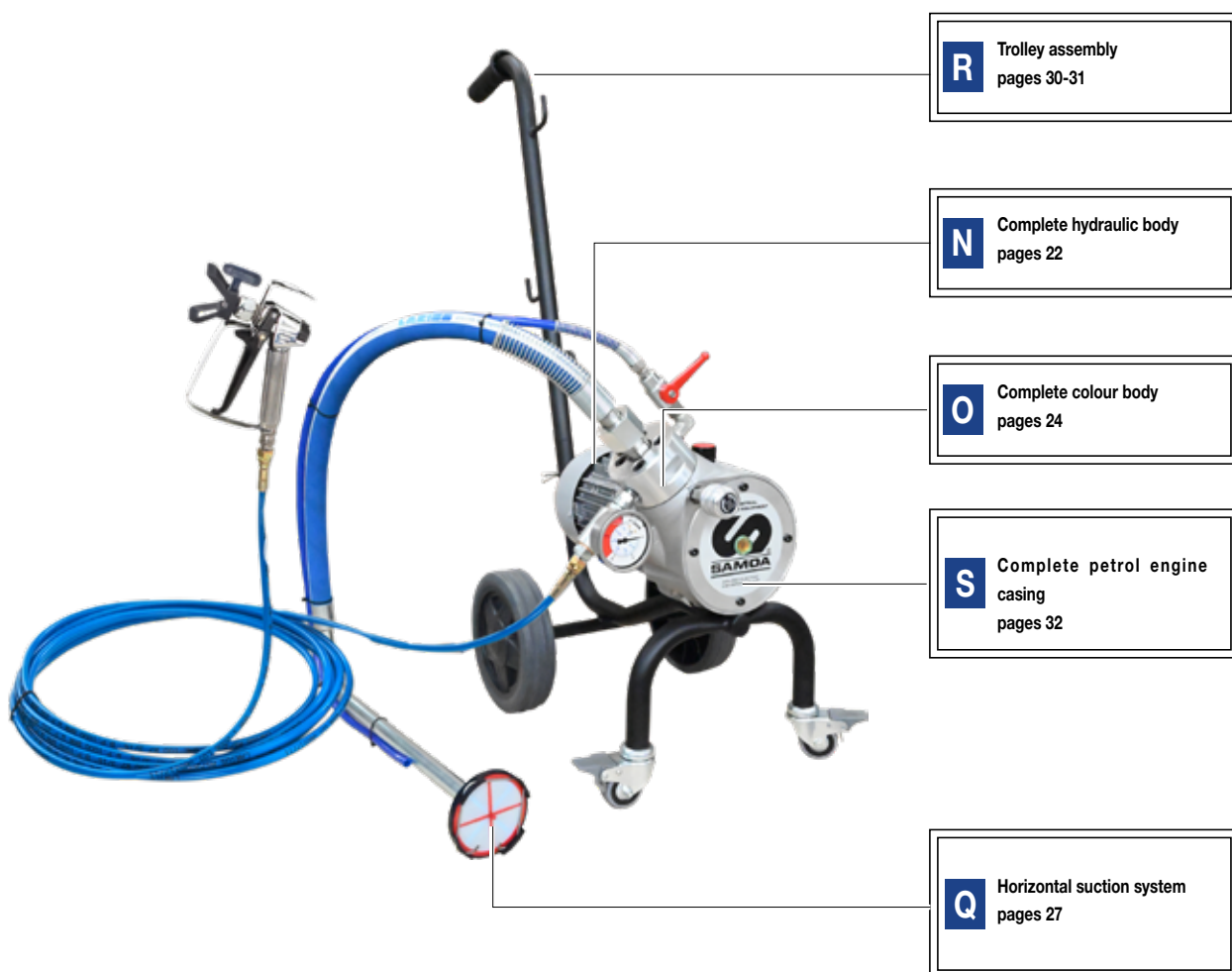

N COMPLETE HYDRAULIC BODY Rif. 21515

WARNING: Always indicate code and quantity for each part required.

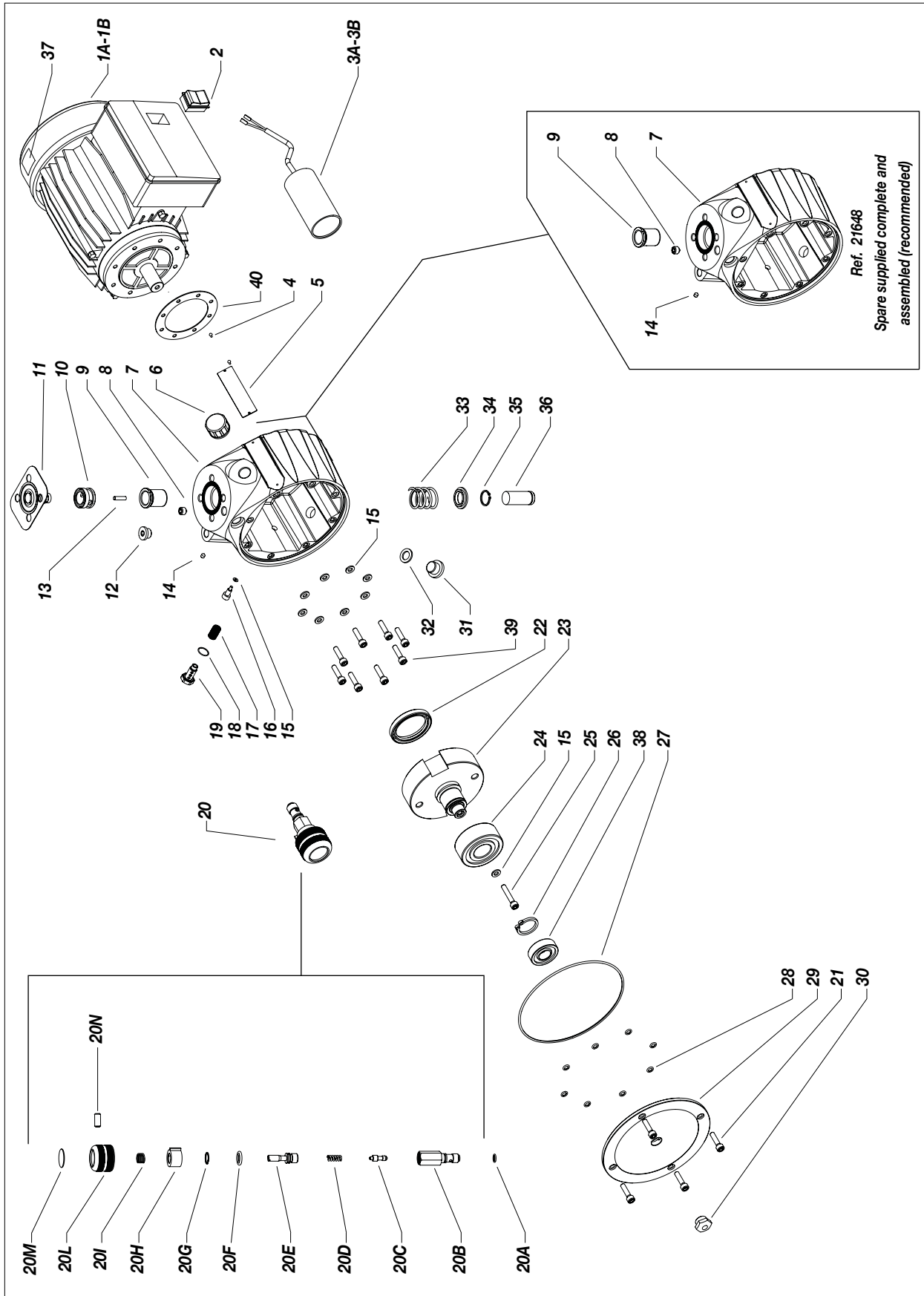

Fig.1

Pos.	Code	Description	Q. ty
1A	21520	Electric motor 240V-50Hz	1
1B	21521	Electric motor 120V-60Hz	1
2	51006	Switch	1
3A	21522	Condenser 440V - 16µf	1
3B	21523	Condenser 440V - 32µf	1
4	34020	Rivet	2
5	21524	Technical Data 120V-60Hz	1
	21525	Technical Data 240V-50Hz	1
6	32006	Plug	1
7	21526	Hydraulic body	1
8	21588	Dowel	1
9	52015	Cylinder liner	1
10	52016	Membrane Spacer	1
11	53002	Membrane Assembly	1
12	8083	Plug	1
13	32042	Elastic pin	1
14	52019	Dowel	1
15	21537	Seal washer	10
16	5727	Stop Bolt	1
17	258	Filter sieve 60 MESH	1
18	95326	ORM	1
19	21532	Filter bolt	1
20	32150	Complete pressure regulation valve	1
20A	32014	OR	1
20B	21534	Valve casing assembly	1
20C	21535	Pin assembly	1
20D	32153	Pin spring	1
20E	32151	Adjustment screw	1

Pos.	Code	Description	Q. ty
20F	32015/2	Elastic ring	1
20G	32015/3	OR	1
20H	32016	Setting catch	1
20I	32017/2	Spring	1
20L	32017/1	Knob	1
20M	16308	Pressure plate	1
20N	32017/1C	Dowel	2
21	54004	Screw	4
22	18909/1	Corteco	1
23	21538	Handwheel assembly	1
24	21540	Bearing	1
25	21556	Screw	1
26	21541	Elastic ring	1
27	21542	OR	1
28	301013	OR	8
29	21543	Front cap	1
30	32007	Oil inspection window	1
31	32108	Oil cap	1
32	33010	Gascket	1
33	52014	Return spring	1
34	52013	Stop ring	1
35	52012	Elastic ring	1
36	21544	Hydraulic piston	1
37	5598	Label	1
38	21559	Roller bearing	1
39	91062	Screw	8
40	21531	Seal motor 1,5 mm	1

Recommended complete spare - To be bought already assembled

Pos.	Code	Description	Q. ty
7	21648	Hydraulic body	1
8		Dowel	1
9		Cylinder liner	1
14		Dowel	1

O COMPLETE COLOUR BODY

WARNING: Always indicate code and quantity for each part required.

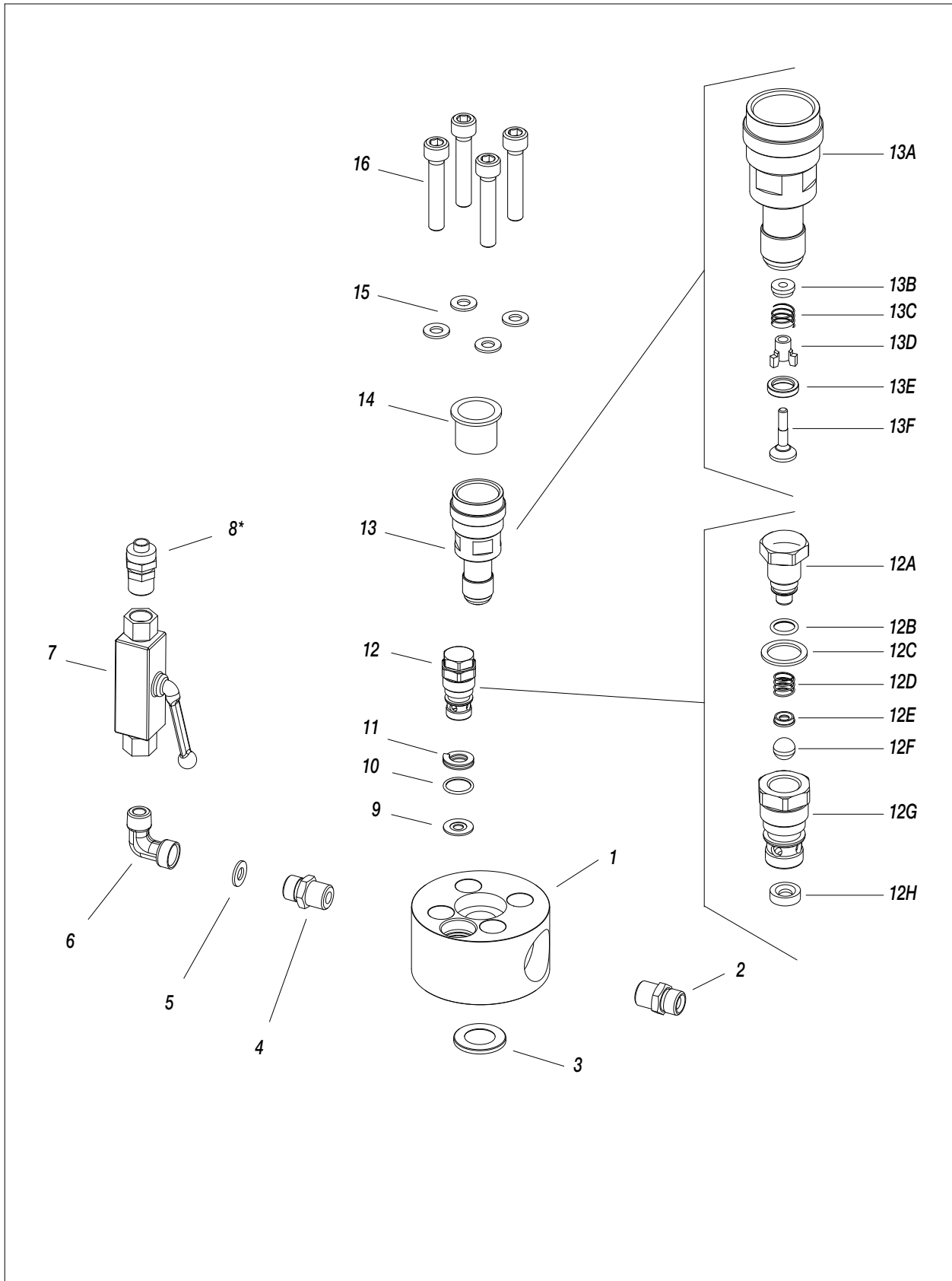

Fig.1

Pos.	Code	Description	Q. ty
-	21620	Gravity model assembly	1
-	21625	Suction model assembly	1
1	21635	Colour body	1
2	95284	Union	1
3	53001	Membrane spacer	1
4	33011	Union	1
5	33012	Washer 1/4"	1
6	18614	Elbow	1
7	33013	Stopcock 1/4"	1
8*	16053	Rapid coupling 1/4" - Ø 10	1
9	33026	Seal	1
10	21633	OR 3062	1
11	21632	Ring BK 3062	1
12	21613	Material valve assembly	1
12A	21638	Valve plug	1
12B	32060	Or	1

Pos.	Code	Description	Q. ty
12C	33010	Washer	1
12D	53006	Spring	1
12E	33029	Spring housing	1
12F	33028	Ball	1
12G	21637	Valve casing	1
12H	33027	Sphere seat	1
13	21590	Suction valve assembly	1
13A	21549	Valve casing	
13B	53004/6	Catch	
13C	53004/5	Spring	
13D	53004/4	Guide	
13E	53004/2	Shutter seat	
13F	53004/3	Shutter	
14	96099	Gasket	1
15	33005	Washer Ø 10	4
16	33004	Screw M10x55	4

*Coupling that can be used with the vertical circulation system (Ref. 18569) and horizontal system (Ref. 21645)

P VERTICAL SUCTION SYSTEM

WARNING: Always indicate code and quantity for each part required.

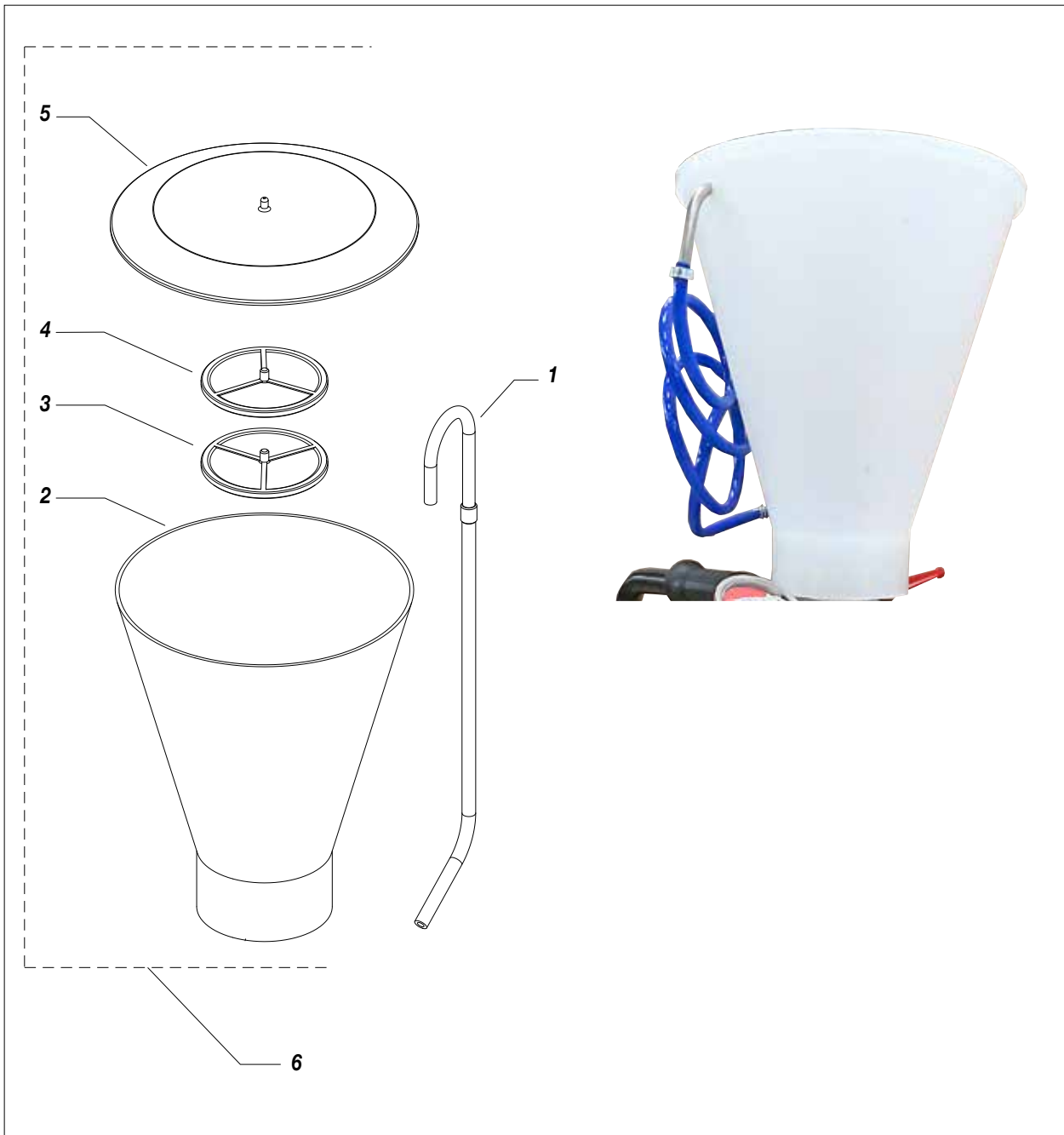

Fig.1

Pos.	Code	Description	Q. ty
1	18569	Recirculation tube	1
2	35103	Tank	1
3	35006	Close filter	1

Pos.	Code	Description	Q. ty
4	35007	Large filter	1
5	55000	Cover	1
6	35101	Tank assembly	1

Q HORIZONTAL SUCTION SYSTEM

WARNING: Always indicate code and quantity for each part required.

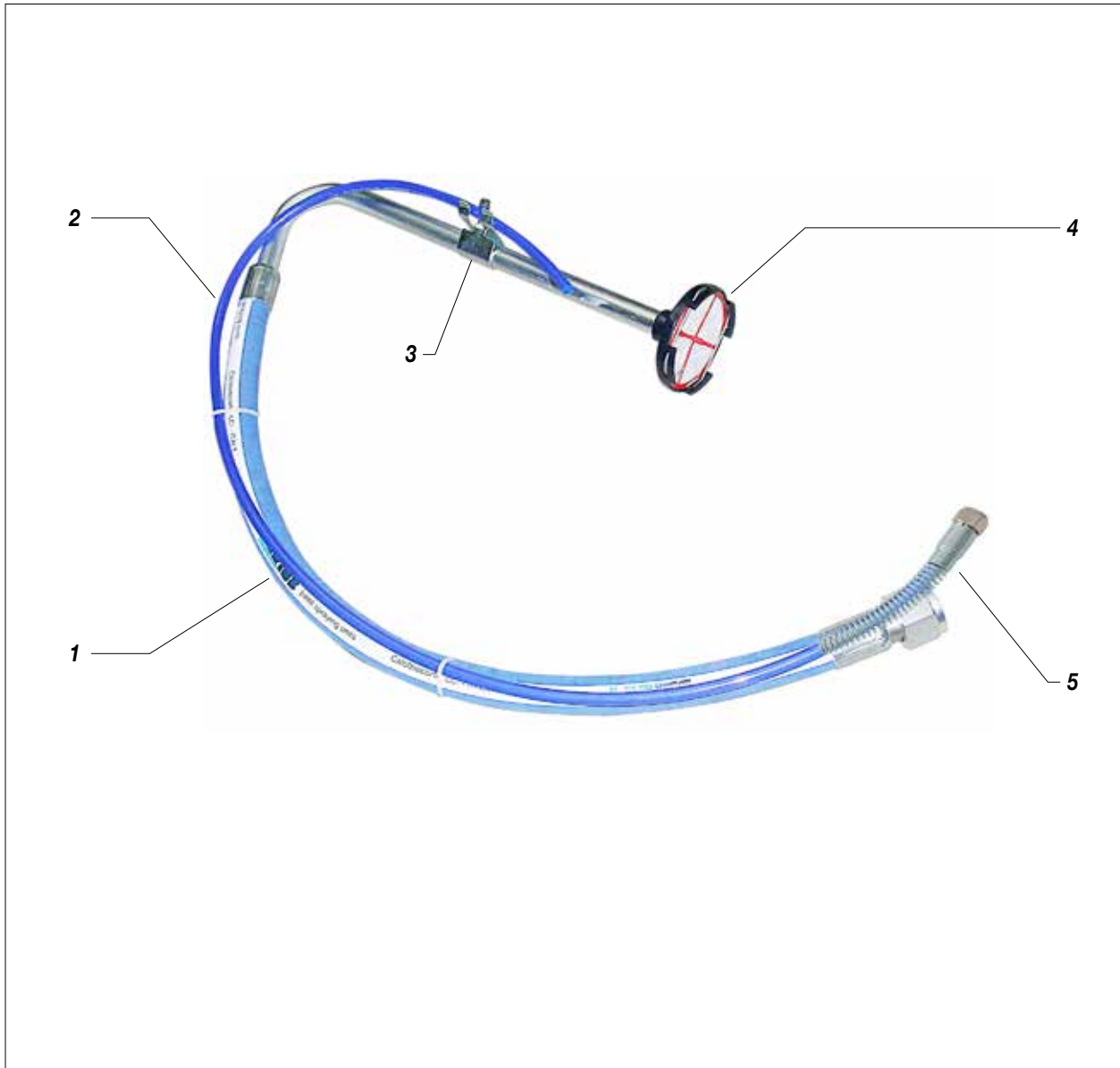

Fig.1

Pos.	Code	Description	Q. ty
-	21645	Suction systems	1
1	21646	Suction tube	1
2	18170	Recirculation tube	1
3	18095	Spring	1
4	21647	Filter of suction	1
5	16066	Nut with spring	1

R TROLLEY ASSEMBLY

WARNING: Always indicate code and quantity for each part required.

WHEELED CARRIAGE ASSEMBLY

Pos.	Code	Description	Q. ty
1	21680	Complete assembly	1
2	12454	Vibration damper	2
3	21652	Threaded cap	2
4	69014	Screw	3
5	21681	Carriage	1
6	91047	Stop washer	4
7	21682	Pneumatic wheel	2
8	21683	Split pin	1
9	21688	Plug	1
10	21685	Handle	1
11	34012	Knob	1
12	8043	Or	2

Fig.1

FIXED CHASSIS ASSEMBLY

Pos.	Code	Description	Q. ty
1	21650	Complete assembly	1
2	12454	Vibration damper	2
3	21652	Threaded cap	2
4	69014	Screw	3
5	21651	Trolley	1
6	21653	Plug	2
7	34012	Knob	1
8	21688	Plug	1
9	8043	Or	2

Fig.2

PETROL ENGINE CARRIAGE

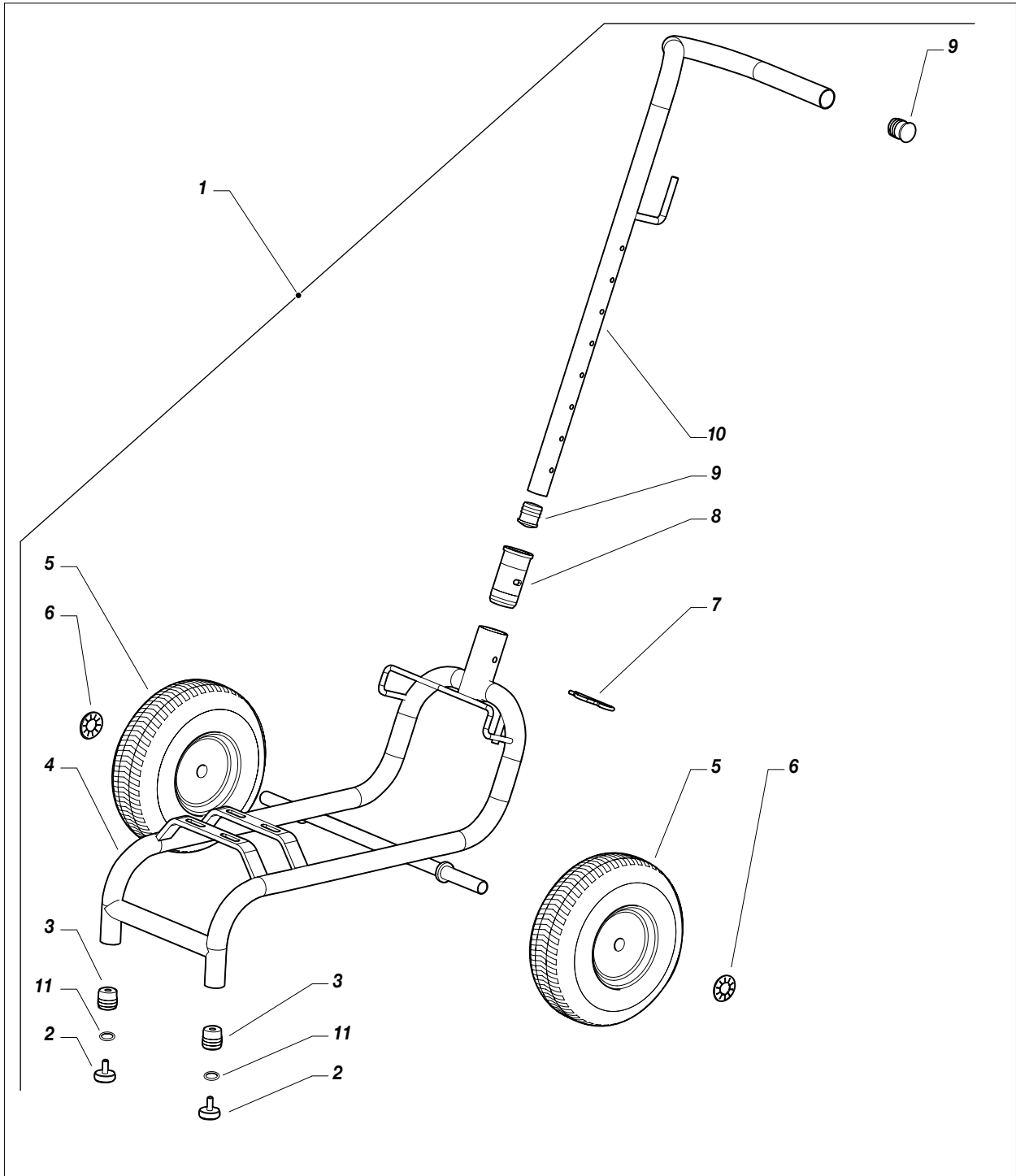

Fig.3

Pos.	Code	Description	Q. ty
1	18911	Complete carriage	1
2	12454	Vibration damper foot	2
3	12473	Threaded cap	2
4	18913	Trolley frame	1
5	37218	Pneumatic wheel	2
6	91047	Wheel stop washer	2

Pos.	Code	Description	Q. ty
7	18902	Split pin	1
8	18914	Bushing	1
9	95159	Pipe cap	2
10	18912	Handle	1
11	8043	Or	2

S COMPLETE PETROL ENGINE CASING

WARNING: Always indicate code and quantity for each part required.

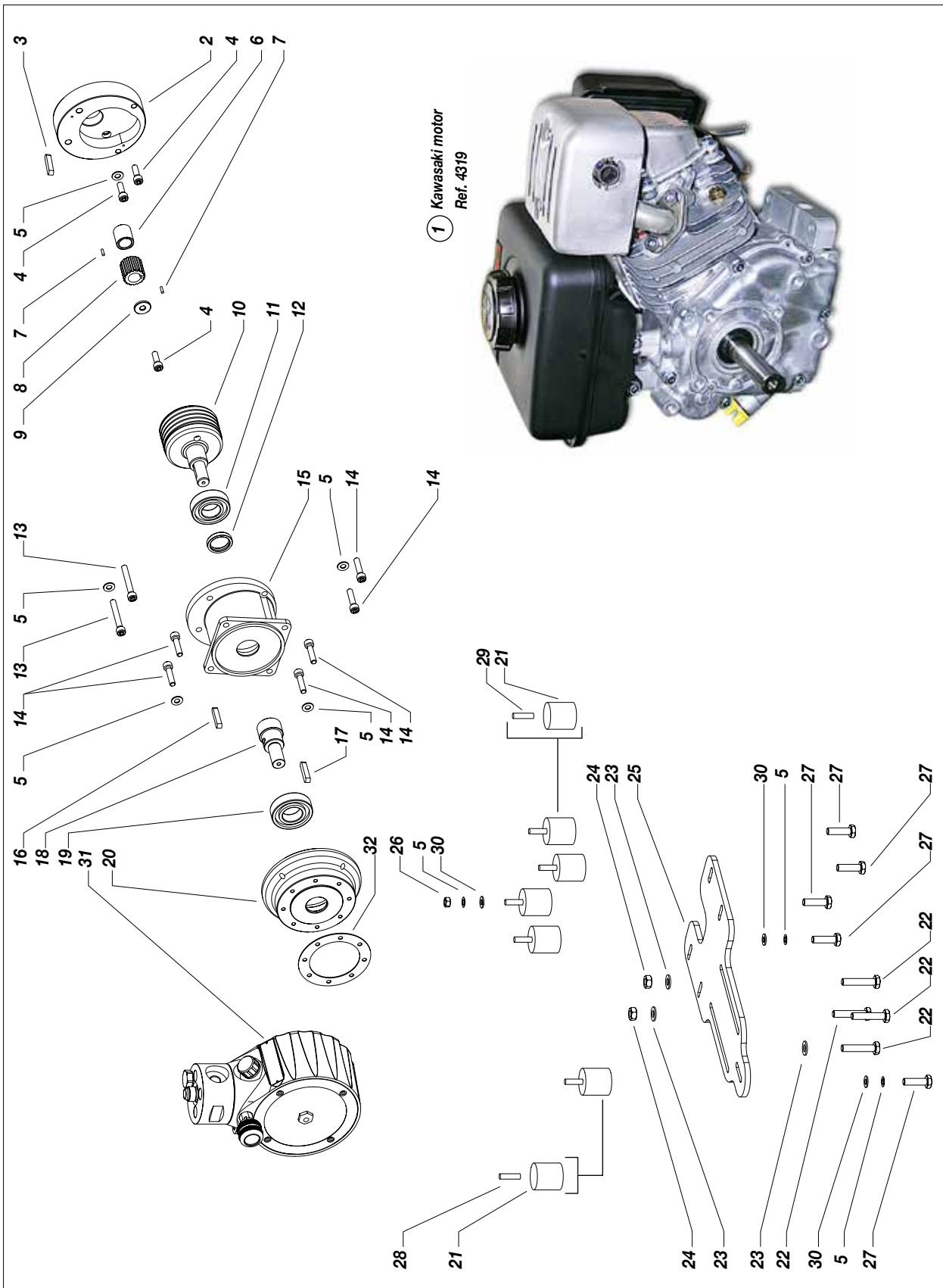

Fig.1

Pos.	Code	Description
1	4319	Motor
2	4237M	Motor flange
3	4244M	Machined tang
4	18935	Screw
5	34009	Washer
6	4238M	Spacer
7	4233	Pin
8	4239M	Toothed pinion
9	4241M	Tightening ring
10	4240M	Crown gear
11	42255	Bearing
12	31128	Corteco
13	18934	Screw
14	901568	Screw
15	4236M	Reduction flange
16	18916	Tab

Pos.	Code	Description
17	21693	Tab
18	21690	Coupling extension
19	31125	Bearing
20	21691	Connection flange
21	81107	Shock absorber
22	95156	Screw
23	81033	Washer
24	95158	Nut
25	21692	Fixing plate
26	52017	Nut
27	34008	Screw
28	18941	Threaded pin
29	18942	Threaded pin
30	32024	Flat washer
31	21694	Technical data plate
32	21531	Seal motor

Intentionally blank page



CE DECLARATION OF CONFORMITY



Company



LARIUS srl
Via Antonio Stoppani 21 - 23801 Calolziocorte (LC) ITALY
Tel: +39 0341 621152
Fax: +39 0341 621243
E-mail: larius@larius.com

Declares under his owns responsibility that the product:

MIRO' **Electric diaphragm pump**

complies with the directives:

- EC Directive 2006/42 Machinery Directive
- EU Directive 2014/30 Electromagnetic Compatibility (EMC)
- EU Directive 2014/35 Low Voltage (LVD)

furthermore to the
harmonized standards:

- UNI EN ISO 12100-1/-2
Machinery safety, basic concepts, general principles of design. Basic terminology, methodology. Technical principles.

This declaration relates exclusively to the product in the state in which it was placed on the market, and excludes components or modifications which are added or carried out subsequently by end user.

Signature

Pierangelo Castagna
Managing Director

Calolziocorte, 8 January 2024
Location / Date

**SAMOA INDUSTRIAL, S.A. - HEADQUARTERS
SPAIN AND EXPORT MARKETS**

POL. IND. PORCEYO, I-14 - CAMINO DEL FONTÁN, 831
E-33392 GIJÓN (ASTURIAS), SPAIN
TEL.: +34 985 381 488 - FAX: + 34 985 147 213

**SAMOA S.A.R.L.
FRANCE**

P.A.E.I. DU GIESSEN
3, RUE DE BRISCHBACH
67750 SCHERWILLER, FRANCE
TEL.: +33 3 88 82 79 62 - FAX: +33 3 88 82 77 88

**SAMOA ITALIA - LARIUS
ITALY**

VIA ANTONIO STOPPANI,21
23801 CALOLZIOCORTE (LC) ITALY
Tel.: +39 0341 621152 - Fax: + 39 0341 621242

SAMOA FLOWTECH GMBH

GERMANY, AUSTRIA, SWITZERLAND, THE NETHERLANDS AND GREECE
AM OBEREICHHOLZ 4
D - 97828 MARKTHEIDENFELD, GERMANY
TEL.: +49 9391 9826 0 - FAX: +49 9391 98 26 50

SAMOA LTD.

UNITED KINGDOM AND REP. OF IRELAND

ASTURIAS HOUSE - BARRS FOLD ROAD
WINGATES INDUSTRIAL PARK
WESTHOUGHTON, BL5 3XP, UK
TEL.: +44 1942 850600 - FAX: +44 1942 812160







SAMOA CORPORATION

USA AND CANADA
90 MONTICELLO ROAD
WEAVERVILLE, NC 28787, USA
TEL. +1 (828) 645-2290 - FAX: +1 (828) 658 0840



©Copyright, SAMOA INDUSTRIAL, S.A.
SAMOA Industrial, S.A. is an ISO 9001, ISO 14001 and ISO 45001 certified company.

 **Contact us today!**
Visit www.samoaindustrial.com for more information.

OPERATING AND MAINTENAINCE MANUAL AVAILABLE IN:		
	IT	https://www.larius.com/wp-content/uploads/MIRO_I.pdf
	EN	https://www.larius.com/wp-content/uploads/MIRO_GB.pdf
	DE	https://www.larius.com/wp-content/uploads/MIRO_D.pdf
	FR	https://www.larius.com/wp-content/uploads/MIRO_F.pdf
	ES	https://www.larius.com/wp-content/uploads/MIRO_E.pdf
	PL	https://www.larius.com/wp-content/uploads/MIRO_PL.pdf
	PR	https://www.larius.com/wp-content/uploads/MIRO_P.pdf