

www.larius.com

Electric Piston Airless Pump

Jolly



56501/5	JOLLY trolley - 220 bar - motor 110V
K56501/5	JOLLY trolley - 220 bar - motor 110V + gun
56501/4	JOLLY trolley - 220 bar - motor 220V
K56501/4	JOLLY trolley - 220 bar - motor 220V + gun

56500/6	JOLLY frame - 220 bar - motor 110V
K56500/6	JOLLY frame - 220 bar - motor 110V + gun
56500/5	JOLLY frame - 220 bar - motor 220V
K56500/5	JOLLY frame - 220 bar - motor 220V + gun



IT https://www.larius.com/wp-content/uploads/JOLLY_I.pdf

EN https://www.larius.com/wp-content/uploads/JOLLY_GB.pdf

DE https://www.larius.com/wp-content/uploads/JOLLY_D.pdf

ES https://www.larius.com/wp-content/uploads/JOLLY_E.pdf

FR https://www.larius.com/wp-content/uploads/JOLLY_F.pdf



This manual is to be considered as an English language translation of the original manual in Italian. The manufacturer shall bear no responsibility for any damages or inconveniences that may arise due to the incorrect translation of the instructions contained within the original manual in Italian.

Due to a constant product improvement programme, the factory reserves the right to modify technical details mentioned in this manual without prior notice.

Jolly

Electric piston pump

INDEX



















A	WARNINGS	4
B	TRANSPORT AND UNPACKING	5
C	CONDITIONS OF GUARANTEE	5
D	SAFETY RULES.....	5
E	WORKING PRINCIPLE	7
F	TECHNICAL DATA	8
G	DESCRIPTION OF THE EQUIPMENT	9
H	PIPE CONNECTION	11
I	OPERATION.....	14
J	CLEANING AT THE END OF THE WORK.....	16
K	GENERAL MAINTENANCE	17
L	ROUTINE MAINTENANCE	17
M	WARNING PLATES.....	18
N	CORRECT PROCEDURE OF DECOMPRESSION	19
O	REPLACEMENT OF THE PUMPING GROUP'S GASKETS.....	20
P	ELECTRIC MOTOR BRUSH REPLACEMENT	29
Q	TROUBLESHOOTING	31
	SPARE PARTS	
R	FRAME	35
S	COMPLETE ELECTRO-MECHANICAL GROUP.....	36
T	COMPLETE HYDRAULIC GROUP	38
U	COMPLETE ELECTRO-HYDRAULIC DRIVING GROUP	40
V	SUCTION AND RECIRCULATION KIT ON FRAME	42
W	ELECTRIC MOTOR BRUSHES	43
X	LINE FILTER	44
Y	TROLLEY	45
Z	SUCTION AND RECIRCULATION GROUP ON TROLLEY	46
	CE DECLARATION OF CONFORMITY	47

**WE ADVISE THE USE OF THIS EQUIPMENT ONLY BY PROFESSIONAL OPERATORS.
 ONLY USE THIS MACHINE FOR USAGE SPECIFICALLY MENTIONED IN THIS MANUAL.**

Thank you for choosing a **SAMOA** product.
 As well as the product purchased, you will receive a range of support services
 enabling you to achieve the results desired, quickly and professionally.

A WARNINGS

The table below provides the meaning of the symbols used in this manual in relation to using, earthing, operating, maintaining, and repairing of this equipment.

	<ul style="list-style-type: none"> • Read this operator's manual carefully before using the equipment. • An improper use of this machine can cause injuries to people or things. • Do not use this machine when under the influence of drugs or alcohol. • Do not modify the equipment under any circumstances. • Use products and solvents that are compatible with the various parts of the equipment, and read the manufacturer's warnings carefully. • See the Technical Details for the equipment given in the Manual. • Check the equipment for worn parts once a day. If any worn parts are found, replace them using ONLY original spare parts. • Keep children and animals away from work area. • Comply with all safety standards.
	<ul style="list-style-type: none"> • It indicates an accident risk or serious damage to equipment if this warning is not followed.
   	<p>FIRE AND EXPLOSION HAZARD</p> <ul style="list-style-type: none"> • Solvent and paint fumes in work area can ignite or explode. • To help prevent fire and explosion: <ul style="list-style-type: none"> - Use equipment ONLY in well ventilated area. - Eliminate all ignition sources, such as pilot lights, cigarettes and plastic drop cloths (potential static arc). - Ground equipment and conductive objects. - Use only grounded hoses. - Do not use trichloroethane, methylene chloride, other halogenated hydrocarbon solvents or fluids containing such solvents in pressurized aluminium equipment. Such use can cause serious chemical reaction and equipment rupture, and result in death, serious injury, and property damage. - Do not form connections or switch light switches on or off if the air contains inflammable fumes. • If electrical shocks or discharges are encountered the operation being carried out using the equipment must be stopped immediately. • Keep a fire extinguisher at hand in the immediate vicinity of the work area.
	<ul style="list-style-type: none"> • It indicates wound and finger squashing risk due to movable parts in the equipment. • Tenersi lontano dalle parti in movimento. • Do not use the equipment without the proper protection. • Before any inspection or maintenance of the equipment, carry out the decompression procedure explained in this manual, and prevent any risk of the equipment starting unexpectedly.
 	<ul style="list-style-type: none"> • Report any risk of chemical reaction or explosion if this warning has not been given. • (IF PROVIDED) There is a risk of injury or serious lesion related to contact with the jet from the spray gun. If this should occur, IMMEDIATELY contact a doctor, indicating the type of product injected. • (IF PROVIDED) Do not spray before the guard has been placed over the nozzle and the trigger on the spray gun. • (IF PROVIDED) Do not put your fingers in the spray gun nozzle. • Once work has been completed, before carrying out any maintenance, complete the decompression procedure.
	<ul style="list-style-type: none"> • It indicates important recommendations about disposal and recycling process of products in accordance with the environmental regulations.
    	<ul style="list-style-type: none"> • Mark any clamps attached to earth cables. • Use ONLY 3-wire extension cords and grounded electrical outlets. • Before starting work make sure that the electrical system is grounded and that it complies with safety standards. • High-pressure fluid from gun, hose leaks, or ruptured components will pierce skin. • To help prevent injection, always: <ul style="list-style-type: none"> - (IF PROVIDED) Engage trigger lock when not spraying. - (IF PROVIDED) Do not put your hand over the spray tip. Do not stop or deflect leaks with your hand, body or other. - (IF PROVIDED) Do not point gun at anyone or at any part of the body. - (IF PROVIDED) Never spray without tip guard. - Do pressure relief if you stop spraying or being servicing sprayer and before any maintenance operations. - Do not use components rated less than sprayer Maximum Working Pressure. - Never allow children to use this unit - (IF PROVIDED) Brace yourself; gun may recoil when triggered. • If high pressure fluid pierces your skin, the injury might look like "just a cut", but it is a serious wound! Get immediate medical attention.
   	<ul style="list-style-type: none"> • It is obligatory to wear suitable clothing as gloves, goggles and face shield. • Wear clothing that complies with the safety standards in force in the country in which the equipment is used. • Do not wear bracelets, earrings, rings, chains, or anything else that may hinder the operator's work. • Do not wear clothing with wide sleeves, scarves, ties, or any other piece of clothing that could get tangled up in moving parts of the equipment during the work, inspection, or maintenance cycles.

B TRANSPORT AND UNPACKING

- The packed parts should be handled as indicated in the symbols and markings on the outside of the packing.
- Before installing the equipment, ensure that the area to be used is large enough for such purposes, is properly lit and has a clean, smooth floor surface.
- The user is responsible for the operations of unloading and handling and should use the maximum care so as not to damage the individual parts or injure anyone.
To perform the unloading operation, use only qualified and trained personnel (truck and crane operators, etc.) and also suitable hoisting equipment for the weight of the installation or its parts.
Follow carefully all the safety rules.
The personnel must be equipped with the necessary safety clothing.
- The manufacturer will not be responsible for the unloading operations and transport to the workplace of the machine.
- Check the packing is undamaged on receipt of the equipment. Unpack the machine and verify if there has been any damage due to transportation.
In case of damage, call immediately the manufacturer and the Shipping Agent. All the notices about possible damage or anomalies must arrive timely within 8 days at least from the date of receipt of the plant through Registered Letter to the Shipping Agent and to the manufacturer.



The disposal of packaging materials is a customer's competence and must be performed in accordance with the regulations in force in the country where the plant is installed and used. It is nevertheless sound practice to recycle packaging materials in an environment-friendly manner as much as possible.

C CONDITIONS OF GUARANTEE



The conditions of guarantee do not apply in the following situations:

- improper washing and cleaning of components causing malfunction, wear or damage to the equipment or any of its parts;
- improper use of the equipment;
- use that does not conform with applicable national legislation;
- incorrect or faulty installation;
- modifications, interventions and maintenance that have not been authorised by the manufacturer;
- use of non-original spare parts or parts that do not correspond to the specific model;
- total or partial non-compliance with the instructions provided.

D SAFETY RULES

- THE EMPLOYER SHALL TRAIN ITS EMPLOYEES ABOUT ALL THOSE RISKS STEMMING FROM ACCIDENTS, ABOUT THE USE OF SAFETY DEVICES FOR THEIR OWN SAFETY AND ABOUT THE GENERAL RULES FOR ACCIDENT PREVENTION IN COMPLIANCE WITH INTERNATIONAL REGULATIONS AND WITH THE LAWS OF THE COUNTRY WHERE THE PLANT IS USED.
- THE BEHAVIOUR OF THE EMPLOYEES SHALL STRICTLY COMPLY WITH THE ACCIDENT PREVENTION AND ALSO ENVIRONMENTAL REGULATIONS IN FORCE IN THE COUNTRY WHERE THE PLANT IS INSTALLED AND USED.



Read carefully and entirely the following instructions before using the product. Please save these instructions in a safe place.



The unauthorised tampering/replacement of one or more parts composing the machine, the use of accessories, tools, expendable materials other than those recommended by the manufacturer can be a danger of accident.



The manufacturer will be relieved from tort and criminal liability.

- KEEP YOUR WORK PLACE CLEAN AND TIDY. DISORDER WHERE YOU ARE WORKING CREATES A POTENTIAL RISK OF ACCIDENTS.
- ALWAYS KEEP PROPER BALANCE AVOIDING UNUSUAL STANCE.
- BEFORE USING THE TOOL, ENSURE THERE ARE NOT DAMAGED PARTS AND THE MACHINE CAN WORK PROPERLY.
- ALWAYS FOLLOW THE INSTRUCTIONS ABOUT SAFETY AND THE REGULATIONS IN FORCE.
- KEEP THOSE WHO ARE NOT RESPONSIBLE FOR THE EQUIPMENT OUT OF THE WORK AREA.
- NEVER EXCEED THE MAXIMUM WORKING PRESSURE INDICATED.
- NEVER POINT THE SPRAY GUN AT YOURSELVES OR AT OTHER PEOPLE. THE CONTACT WITH THE CASTING CAN CAUSE SERIOUS INJURIES. IN CASE OF INJURIES CAUSED BY THE GUN CASTING, SEEK IMMEDIATE MEDICAL ADVICE SPECIFYING THE TYPE OF THE PRODUCT INJECTED. NEVER UNDERVALUE A WOUND CAUSED BY THE INJECTION OF A FLUID.
- ALWAYS DISCONNECT THE SUPPLY AND RELEASE THE PRESSURE IN THE CIRCUIT BEFORE PERFORMING ANY CHECK OR PART REPLACEMENT OF THE EQUIPMENT.
- NEVER MODIFY ANY PART IN THE EQUIPMENT. CHECK REGULARLY THE COMPONENTS OF THE SYSTEM. REPLACE THE PARTS DAMAGED OR WORN.

- TIGHTEN AND CHECK ALL THE FITTINGS FOR CONNECTION BETWEEN PUMP, FLEXIBLE HOSE AND SPRAY GUN BEFORE USING THE EQUIPMENT.
- ALWAYS USE THE FLEXIBLE HOSE SUPPLIED WITH STANDARD KIT. THE USE OF ANY ACCESSORIES OR TOOLING OTHER THAN THOSE RECOMMENDED IN THIS MANUAL, MAY CAUSE DAMAGE OR INJURE THE OPERATOR.
- THE FLUID CONTAINED IN THE FLEXIBLE HOSE CAN BE VERY DANGEROUS. HANDLE THE FLEXIBLE HOSE CAREFULLY. DO NOT PULL THE FLEXIBLE HOSE TO MOVE THE EQUIPMENT. NEVER USE A DAMAGED OR A REPAIRED FLEXIBLE HOSE.



The high speed of the product in the hose can create static electricity through discharges and sparks. It is suggested to earth the equipment.



The pump is earthed through the earth cable of the supply.



The gun is earthed through the high pressure flexible hose.

All the conductors near the work area must be earthed.



Always check the product is compatible with the materials composing the equipment (*pump, spray gun, flexible hose and accessories*) with which it can come into contact. Never use paints or solvents containing halogen hydrocarbons (as *the methylene chloride*).



If these products come into contact with aluminium parts can provoke dangerous chemical reactions with risk of corrosion and explosion.



If the product to be used is toxic, avoid inhalation and contact by using protection gloves, goggles and proper face shields.



Take proper safety measures for the protection of hearing in case of work near the plant.

Electrical safety precautions

- Check the switch is on the "OFF" position before connecting the cable to the mains.
- Never carry a plugged-in equipment.
- Disconnect the equipment before storing it and before performing any maintenance operation or replacing of accessories.
- Do not carry the equipment neither unplug it by pulling the electric cable.
- Protect the cable from heat, oil and sharp edges.



Never attempt to tamper with the calibre of instruments.

- Take care when the pumping rod is moving. Stop the machine whenever someone is within its vicinity.
- Repairs of the electrical equipment should only be carried out by skilled personnel, otherwise considerable danger to the user may result.

E WORKING PRINCIPLE

The **JOLLY** unit is defined “electric piston pump”.

An electric piston pump is used for high pressure painting without air (*from this process derives the term "airless"*).

The pump is controlled by an electric motor coupled with a reduction gear.

A cam shaft and a connecting rod allow to obtain the reciprocating motion necessary to the working of the “pumping group” piston. The piston movement produces a “vacuum”.

The product is sucked, pushed towards the pump outlet and then sent to the gun through the flexible hose.

A electrical device placed next to the reduction gear casing, allows to adjust and control the pressure of the material coming out of the pump.

When the pump reaches the set value, the motor stops and starts again when the value decreases.

A safety valve avoiding overpressure, guarantees the total reliability of the equipment.

INDICATIONS OF USE

To ensure correct operation of the airless electric piston equipment the “minimum power requirements” must be respected. The use of power that is less than that indicated may compromise the integrity and the correct operation of the equipment.

The use of electric cables with a diameter of at least 2.5mm² is recommended; ensure system grounding on the motor generator.

PAINT

Use special paint for airless applications

NOZZLE

Pair the nozzle with the type of work to be carried out in order to optimise the finishing quality and the speed of application. The nozzle is identified through the numbers printed on it: the first number indicates the diameter of the mouth while the second number indicates the spraying angle.



Fig. 1
Version on TROLLEY

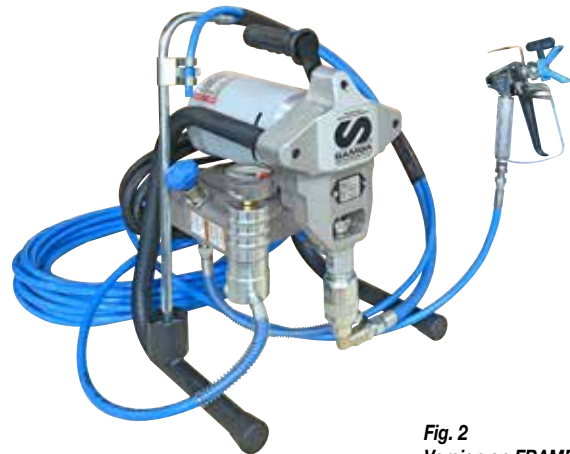

Fig. 2
Version on FRAME

	COD.	MOTOR	HOSE	GUN
FRAME	56500/6	110 V		
	K56500/6	110 V	•	Cod. 11255
	56500/5	220 V		
	K56500/5	220 V	•	Cod. 11255
TROLLEY	56501/5	110 V		
	K56501/5	110 V	•	Cod. 11255
	56501/4	220 V		
	K56501/4	220 V	•	Cod. 11255

Fields of application	Applications materials	
Indoor	Lacquer	Paints
Outdoor	Waterborne	Emulsions
Industrial buildings	Acrylic	Impregnants
Industrial constructions	Primer	Antirust
Redeveloping	Enamels	Primer
Roofing	Fixative	

F TECHNICAL DATA

	JOLLY
Max. delivery	1,9 l/m
Max working pressure	220 bar
Motor power	0,7 Kw
Voltage	110 VAC
	220 VAC
Weight	15 Kg - frame / 16Kg trolley
Max. nozzle size	0,021"
Power generation	4 Kw Single phase
Material outlet	1/4" NPT-NPSM
Sound pressure level	≤80 dB (A)
Length	(A) 450 mm - frame
	(A) 580 mm - trolley
Width	(B) 460 mm- frame
	(B) 540 mm- trolley
Height	(C) 550 mm- frame
	(C) 995 mm- trolley

PARTS OF THE PUMP IN CONTACT WITH THE MATERIAL:

Stainless Steel AISI 420B, PTFE, Aluminium

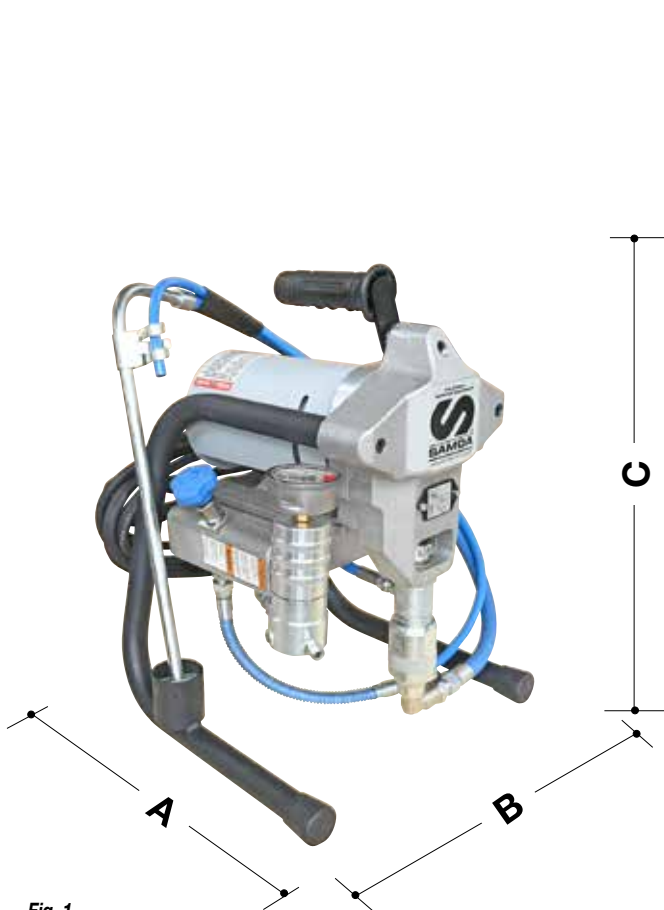

Fig. 1
Version on FRAME



Fig. 2
Version on TROLLEY

G DESCRIPTION OF THE EQUIPMENT

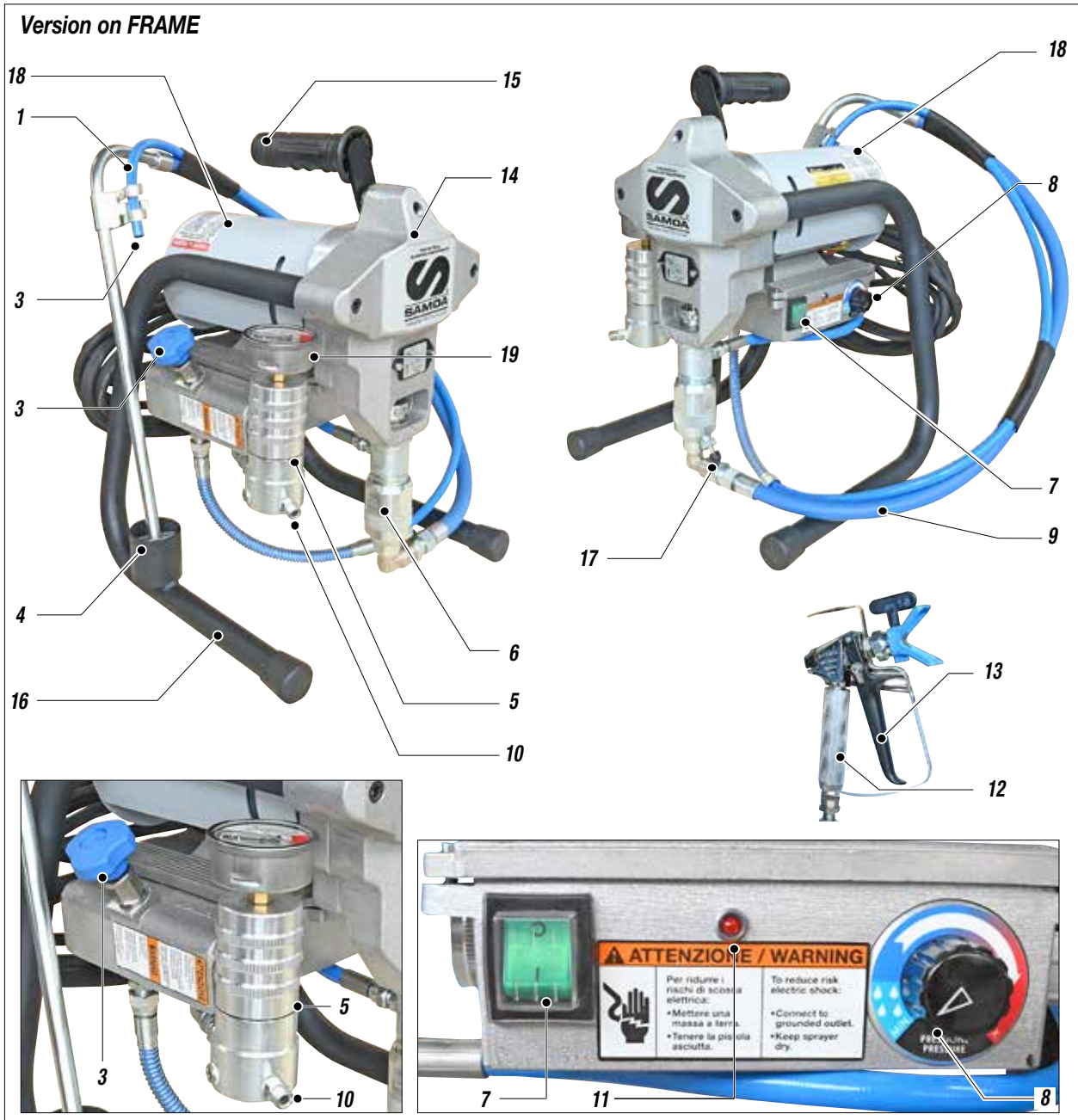

Fig. 1

Pos.	Description
1	Recirculation tube
2	Output product recirculation
3	Safety-recirculation valve
4	Suction filter
5	Plug filter
6	Pumping group
7	ON/OFF switch
8	Potentiometer for adjusting the operating pressure
9	Suction product pipe
10	Coupling for product delivery

Pos.	Description
11	Alarms indicator light
12	Airless manual gun
13	Trigger safety clamp
14	Reduction box
15	Handle/Handgrip
16	Frame
17	Unlocking manual device
18	Product delivery tube
19	Manometer



Fig. 2

Pos.	Description
20	Trolley
21	Suction tube
22	Recirculation hose
23	Wheel

Pos.	Description
24	Product delivery tube coupling
25	Unlocking manual device
26	Electric motor
27	Product delivery tube

H PIPE CONNECTION

CONNECTING THE FLEXIBLE HOSE TO THE GUN

- Connect the high pressure flexible hose (1) to the pump (2) and to the gun (3) ensuring to tighten the fittings (the use of two wrenches is suggested). NEVER use sealants on fittings' threads. It is ADVISED to mount a high pressure manometer at the pump outlet (see on page "Accessories") to read the product pressure.
- It is recommended to use the hose provided with the standard kit (ref. 18036). NEVER use a damaged or a repaired flexible hose.

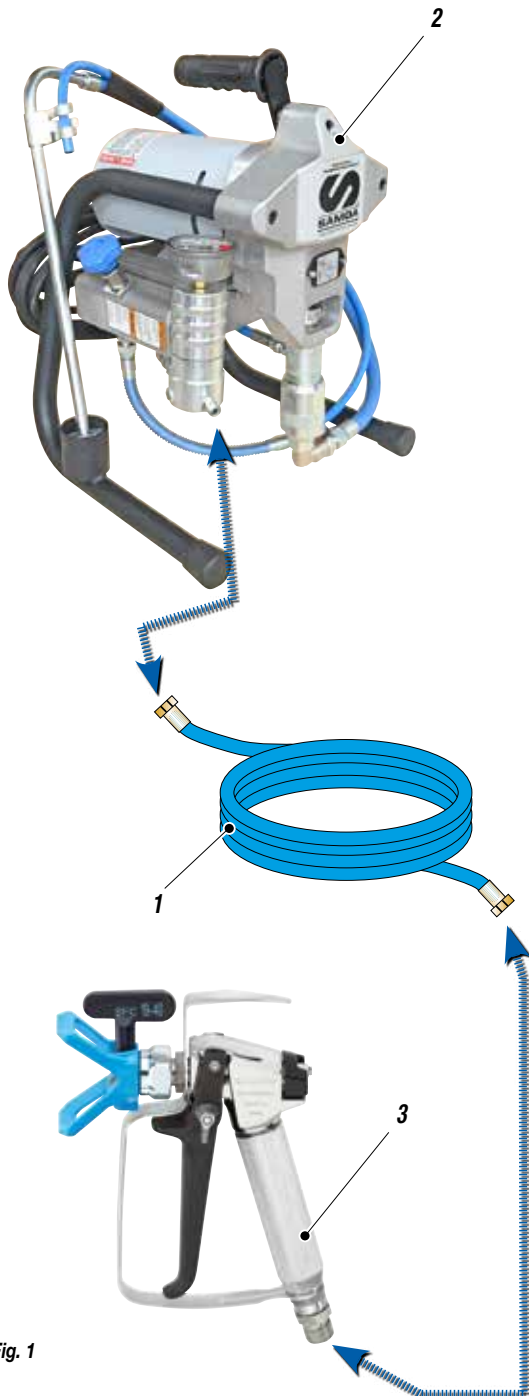

Fig. 1

CHECK ON POWER SUPPLY



Make sure that the electrical system is earthed and complies with regulations.

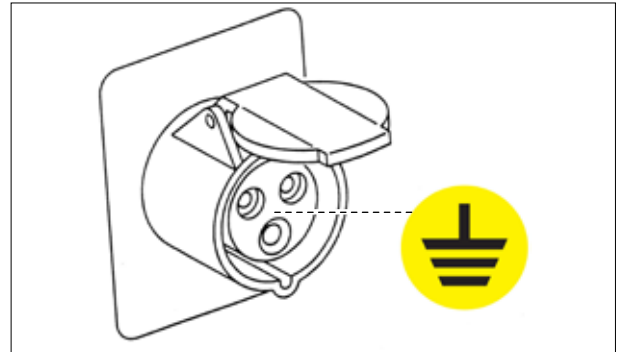

Fig. 2

- Check the mains voltage corresponds to 230 Vac - 50Hz.
- The supply electric cable (H4) of the equipment is provided without the plug. Use a plug which guarantees the plant earthing. Only a technician or a skilled person should perform the connection of the plug to the electric cable.

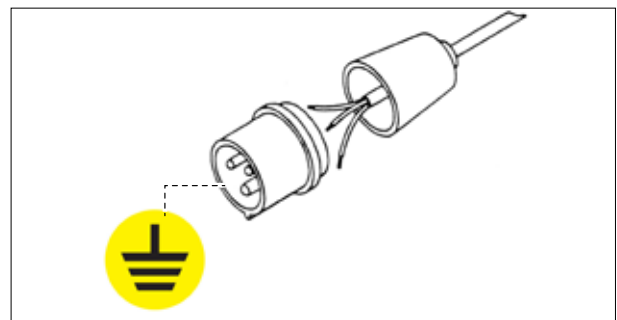

Fig. 3



Should anyone use an extension cable between the unit and the socket, it must have the same characteristics as the cable supplied (*minimum diameter of the wire 2.5 mm²*) with a maximum length of 50 mt. Higher lengths and lower diameters can cause excessive voltage falls and a bad operation of the equipment.

CONNECTING THE EQUIPMENT TO THE POWER SUPPLY

- Check that the switch (H5) is on the “OFF” (0) position before connecting the cable to the mains.
- Place the pressure control knob (6) on the “MIN” position (turn counterclockwise).

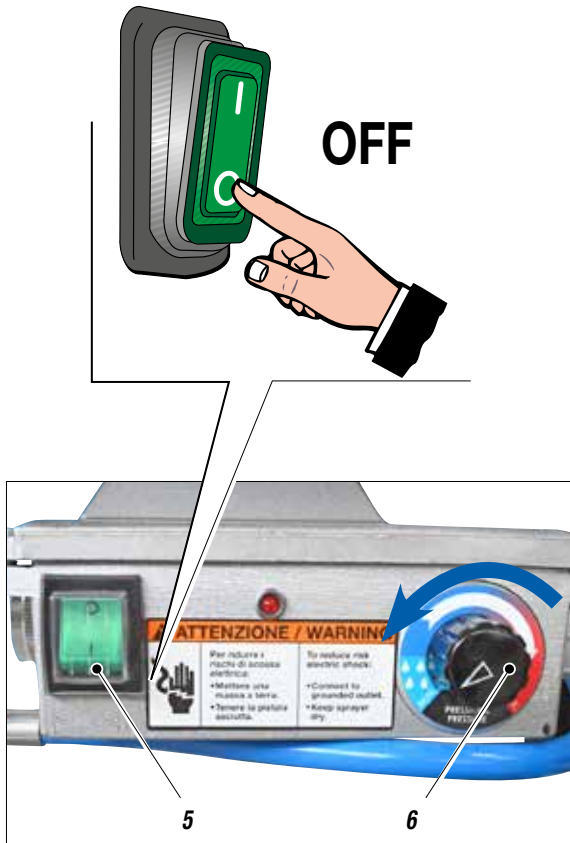

Fig. 4

- Lift the suction group and dip it into the tank containing the washing liquid.
- Press the equipment main switch (5) on pos. “ON” (I).

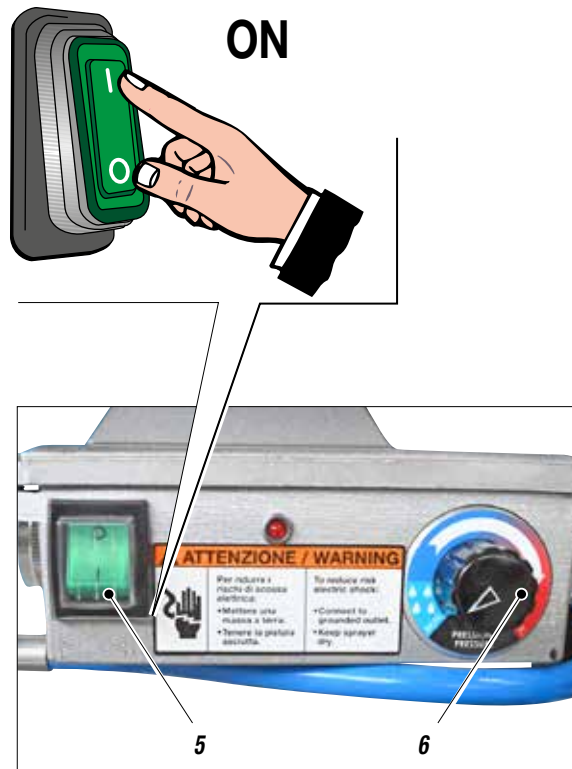

Fig. 6

- Open the recirculation-safety valve (7).

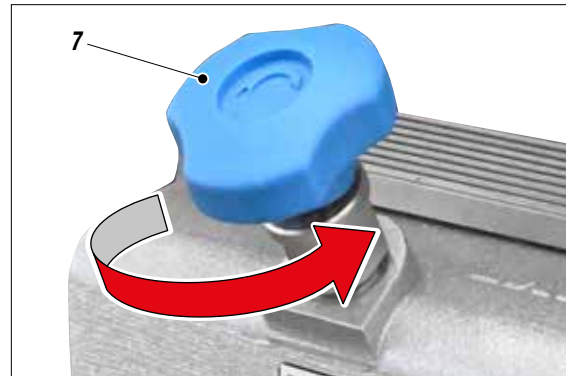

Fig. 7

Washing of the new equipment

- The equipment has already been adjusted at our factory with light mineral oil left inside the pumping group as protection. Therefore, wash with diluent before sucking the product.
- Ensure the gun (3) is without nozzle.

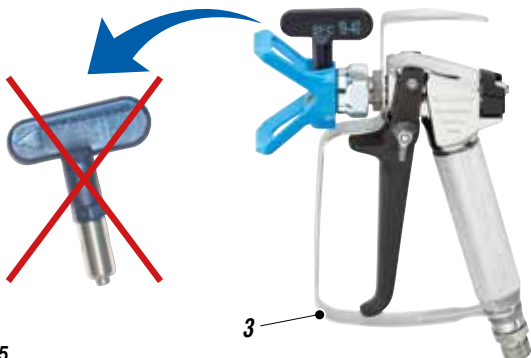

Fig. 5

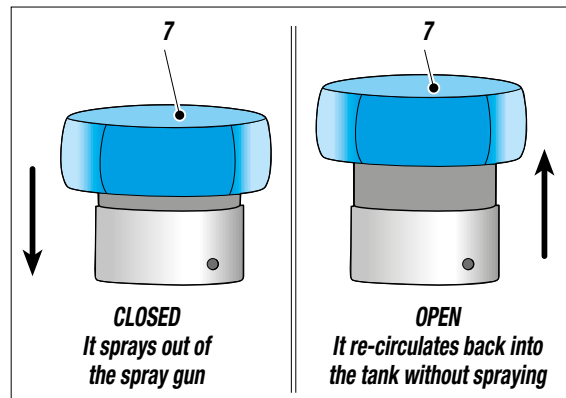

Fig. 8

- Turn the pressure regulating knob (6) clockwise to the position "RECIRCULATION AND WASHING" (see drops) so that the machine idles.

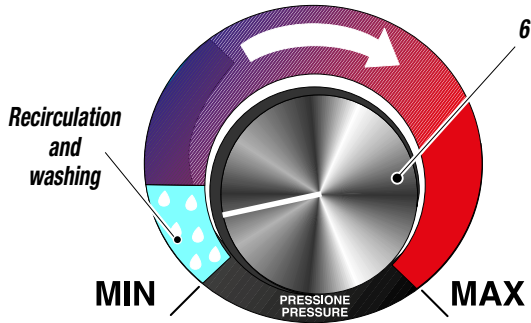

Fig. 9

- Visually check that the washing liquid starts to re-circulate within the tank (8).



Fig. 10

- Turn the pressure adjustment handle (6) counterclockwise to stop the pump.
- Close the recirculating-safety valve (7).



Fig. 11

- Turn pressure regulating knob (H6) slightly clockwise so that the machine idles.

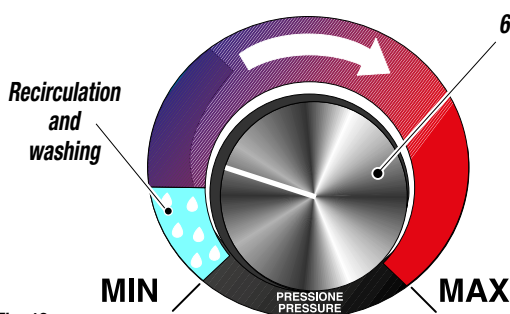

Fig. 12

- Point the gun (3) into a collecting tank (8) keeping the trigger pressed (so as to drain the oil inside) till a clean solvent comes out. Now, release the trigger.

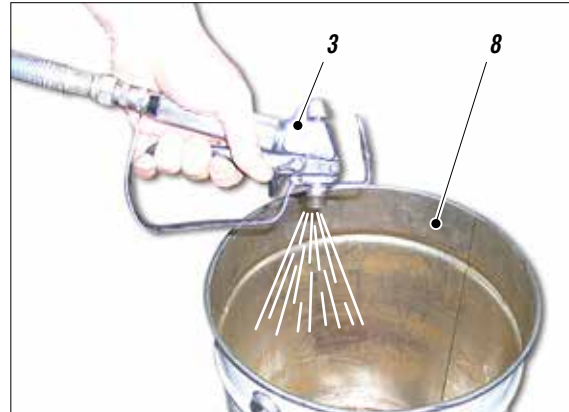

Fig. 13

- Remove the suction pipe (9) and take away the solvent tank (8).
- Point the gun into the solvent tank (8) and press the trigger so as to recover the residual solvent.
- As the pump idles, press the "OFF" (0) switch to stop the unit.



Never spray solvents indoors. In addition, it is recommended to keep far from the pump in order to avoid the contact between the solvent fumes and the electric motor.

- Now the machine is ready. Should you use water paints, beside washing with the solvent, it is suggested to wash with soap and clean water.
- Insert the gun trigger lock and fix the nozzle.

PREPARATION OF THE PAINT

- Make sure the product is suitable to be used with a spray gun.
- Mix and filter the product before using it. For filtration, use **CLOSE-MESH (ref. 214)** and **LARGE-MESH (ref. 215) LARIUS METEX** braids.



Make sure the product to be used is compatible with the materials employed for manufacturing the equipment (stainless steel and aluminium). For further information, please contact the supplier of the product.

Never use products containing halogen hydrocarbons (as *methylene chloride*). If these products come into contact with aluminium parts of the equipment, they can cause dangerous chemical reactions with risk of explosion.

I OPERATION

START OF THE PAINTING OPERATIONS

- Use the equipment only after performing all the **SETTING UP** operations described above.
- Dip the suction pipe (1) into the product tank.

Version on **FRAME**



Fig. 1

Version on **TROLLEY**



Fig. 2

- Open the recirculating-safety valve (2) (turn clockwise so as the pin slides on the cam track).

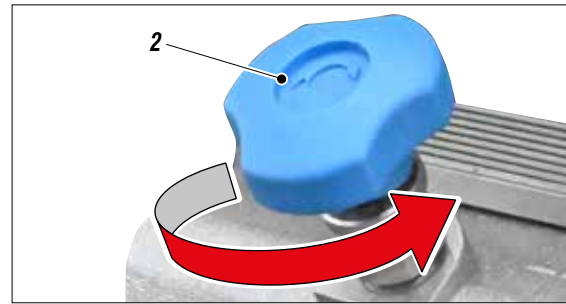

Fig. 3

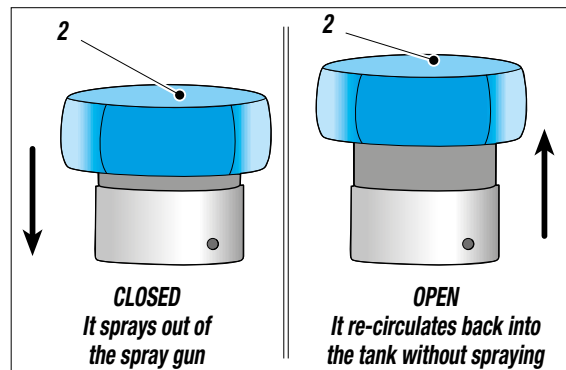

Fig. 4

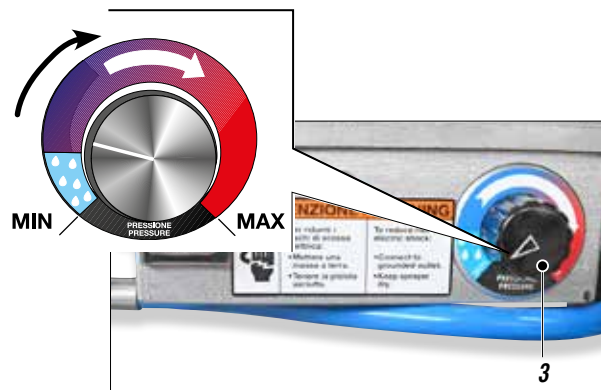

Fig. 5

- Make sure the product recycles from the recirculation tube (4).



Fig. 6

- Close the recirculating-safety valve (2) (turn clockwise to release the valve).

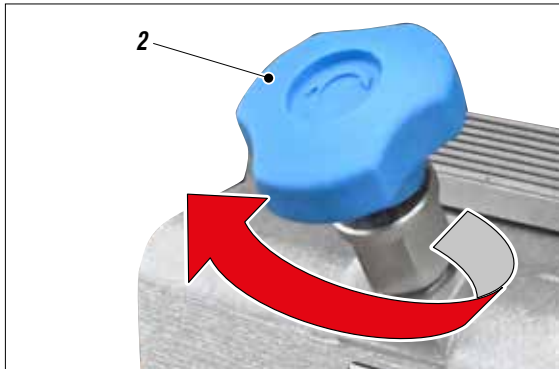

Fig. 7

- The machine will continue to suck the product till the flexible hose is full up to the set pressure. Then it will automatically stop.
- Adjust the operation pressure with the knob (3).

SPRAY ADJUSTMENT

- Slowly turn clockwise the pressure control knob to reach the pressure value in order to ensure a good atomization of the product.
- An irregular and marked spray on the sides indicates a low working pressure. On the contrary, a too high pressure causes a high fog (“overspray”) and waste of product.
- In order to avoid overthickness of paint, let the gun advance sideways (right-left) when spraying.
- Always paint with regular parallel bands coats.
- Keep a safety and constant distance between the gun and the support to be painted and also keep yourselves perpendicular to it.



Never point the spray gun towards yourselves or other people. The contact with the casting can cause serious injuries.



In case of injuries caused by the gun casting, seek immediate medical advice specifying the type of the product injected.



Recirculating-safety valve: when working at the maximum pressure available, releasing the gun trigger can cause sudden increases of pressure. In this case, the recirculating-safety valve opens automatically discharging part of the product from the recirculating tube. Then it closes so as to go back to the previous working conditions.

PROCEDURE TO UNLOCK THE SUCTION GROUP BALL

Should the ball of the suction group be blocked, the unit does not suck the product anymore.

Procedere to manually release the ball as follows:

- Press several times the suitable device (5).

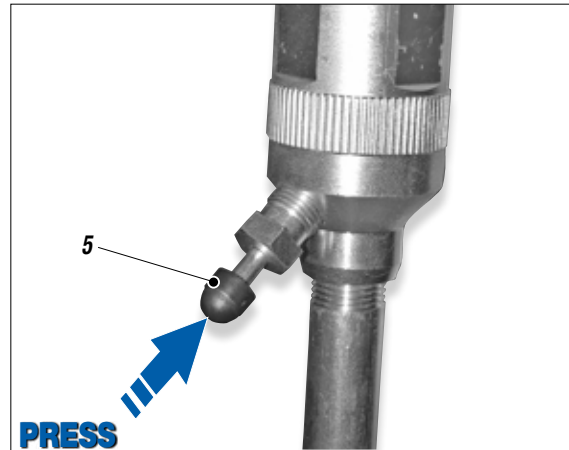

Fig. 8

ALARMS

- Flashing lamp (6) for alarms:

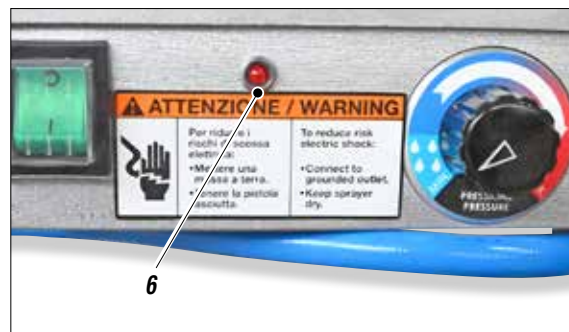









Fig. 9



For all alarms, the machine shuts down and signals the type of abnormality by means of a series of flashes.

As for alarm No. 6, light signalling through a series of uninterrupted flashes is provided without machine shut-down. The operator must, however, immediately connect the unit to an adequate grounding system.

The manufacturer assumes no responsibility for failure to comply with this requirement.

LED	ALLARMI - ALARMS WARNMELDUNGEN - ALARME
	CORRENTE MASSIMA SUPERATA MAXIMUM CURRENT EXCEEDED MAX. STROM ÜBERSCHRITTEN MAXIMUM COURANT DÉPASSÉE
	SURRISCALDAMENTO HEAD CONTROL OVERHEATING HEAD CONTROL ÜBERHITZUNG HEAD CONTROL SURCHAUFFAGE HEAD CONTROL
	MOTORE IN CORTO CIRCUITO MOTOR SHORT CIRCUIT MOTOR IN KURZSCHLUSS MOTEUR COURT-CIRCUITÉ
	TENSIONE DI ALIMENTAZIONE ALTA HIGH VOLTAGE FEEDING CURRENT HOHE VERSORGUNGSSPANNUNG TENSION D'ALIMENTATION À L'ENTRÉE TROP ÉLEVÉE
	TENSIONE DI ALIMENTAZIONE BASSA LOW VOLTAGE FEEDING CURRENT NIEDRIGE VERSORGUNGSSPANNUNG TENSION D'ALIMENTATION À L'ENTRÉE TROP FAIBLE
	MANCANZA CONNESSIONE A TERRA NO EARTHING KEINE ERDUNG PAS DE MISE À TERRE <div style="border: 1px solid black; padding: 5px;"> <p>Continuous flashing indicates a lack of grounding connection while the machine continues to work. The operator must, however, immediately connect the unit to an adequate grounding system. The manufacturer assumes no responsibility for failure to comply with this requirement.</p> </div>
	SENSORE DI PRESSIONE GUASTO PRESSURE SENSOR FAULT DRUCKKNOPFANSCHLUSS DEFEKT CAPTEUR DE PRESSION EN PANNE
	BLOCCO RICIRCOLO (DOPO 15 MIN.) RECYCLING STOP (AFTER 15 MIN.) ABSCHALTUNG DES RUCKLAUFS (NACH 15 MIN.) ARRET RECYCLAGE (APRÈS 15 MIN.)

J CLEANING AT THE END OF THE WORK

- Reduce pressure to the minimum (*turn counterclockwise the pressure control knob (1)*).
- Press the switch (2) placed on the box of the electric motor, to stop the equipment.



Fig. 1

- Release the residual pressure by holding down the trigger of the gun and pointing it into a container.
- Open the recirculating-safety valve (3) to release the pressure in the circuit.

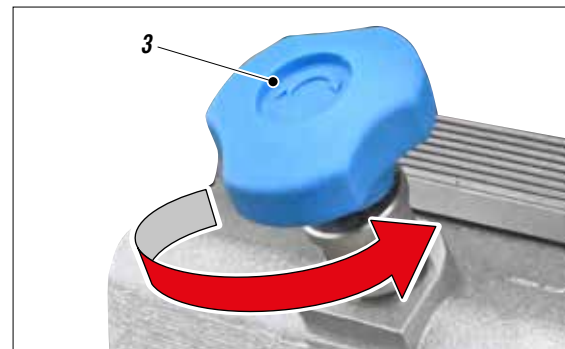

Fig. 2

- Lift the suction pipe and replace the product container with the solvent tank (*ensure it is compatible with the product being used*).
- Unscrew the gun nozzle (*remember to clean it with solvent*).
- **Press the switch (2) ON and slightly turn the pressure control knob (1) clockwise so as the machine works till the motor starts.**
- Make sure the solvent recycles the washing liquid from the recirculation tube.
- Close the recirculating-safety valve (3).
- Point the gun (4) into the product container (5) and, keeping the trigger pressed, release the remaining product till a clean solvent comes out. Now, release the trigger.

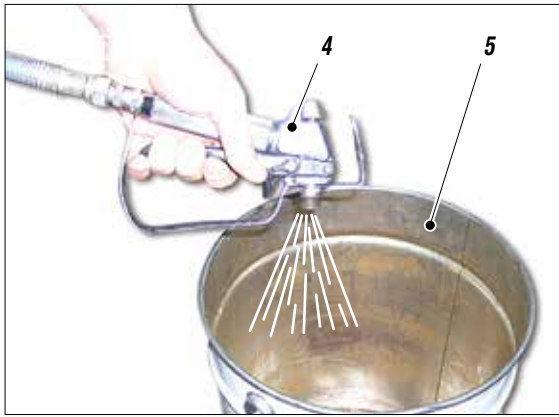

Fig. 3

- Lift again the suction pipe and remove the solvent tank.
- Now point the gun into the solvent tank and press the trigger so as to recover the residual solvent.
- **As the pump starts idling, press the switch OFF (0) to stop the equipment.**
- In case of long storage, we recommend you to suck and to leave light mineral oil inside the pumping group and the flexible hose.



Follow the washing procedure before using again the equipment.

K GENERAL MAINTENANCE



Before performing any maintenance operation, discharge the pressure in the pumping unit (*open the drain valve*).

DAILY

- Clean the filters;
- Clean the nozzles;
- Clean the painting circuit with a suitable product.

PERIODICALLY

- Check the pumping gaskets tightening (*if the product draws, replace the gaskets*);
- Clean the mobile parts from the varnish deposits (*spray guns, etc.*);
- Check that the tubes and all the fittings are correctly tightened.

L ROUTINE MAINTENANCE

CHECK ON THE PACKING NUT

Daily check the packing nut is tight in order to avoid wastes but **not excessively to prevent the piston from seizing and the gaskets from wearing.**

- For tightening, use the wrench supplied (*ref. 11503*).

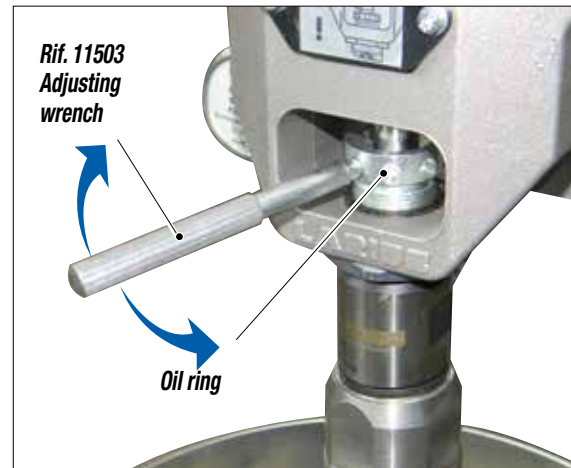

Fig. 1



ALWAYS DISCONNECT THE POWER SUPPLY AND RELEASE THE PRESSURE IN THE PUMPING GROUP (*open the drain valve*) BEFORE TIGHTENING THE PACKING NUT.

- Use the lubricant supplied (*ref. 16340*) to allow an easy sliding of the piston inside the gasket group.
Daily top up the packing nut.



Fig. 2



M WARNING PLATES

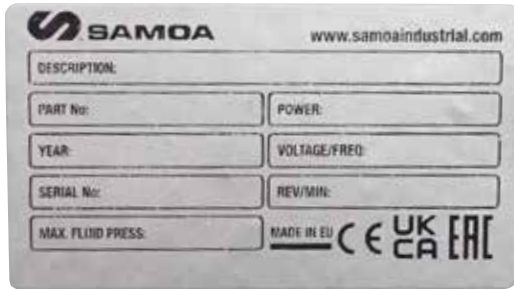

N CORRECT PROCEDURE OF DECOMPRESSION

- Insert the gun clamp (1).

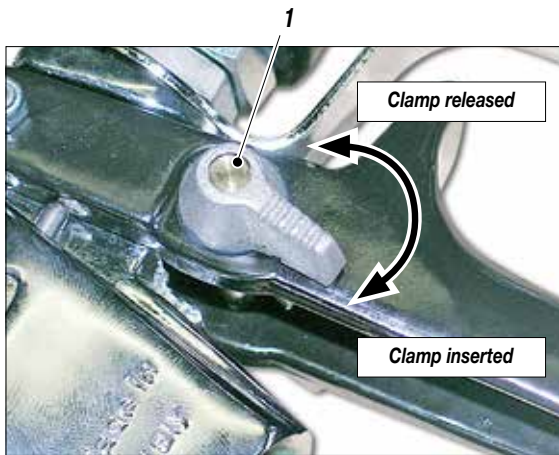

Fig. 1

- Move the switch (2) to the **OFF** position to stop the equipment.
- Reduce pressure to the minimum (turn counterclockwise the pressure control knob (3)).

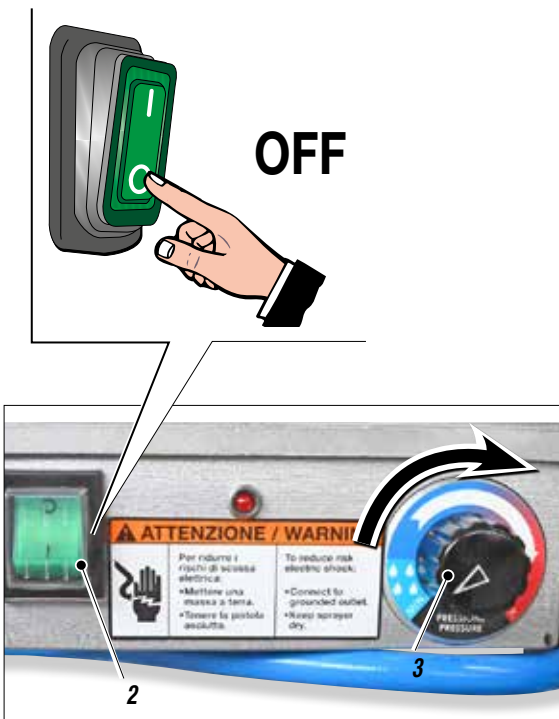

Fig. 2

- Disconnect the power supply cable (4).

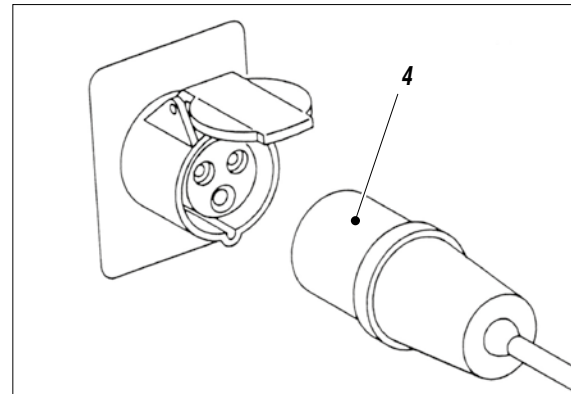

Fig. 3

- Release the gun clamp (1), point the gun into the tank of the product and press the trigger to release pressure. At the end of the operation, insert the gun clamp.
- Open clockwise the recirculating-safety valve (5) to release the residual pressure.

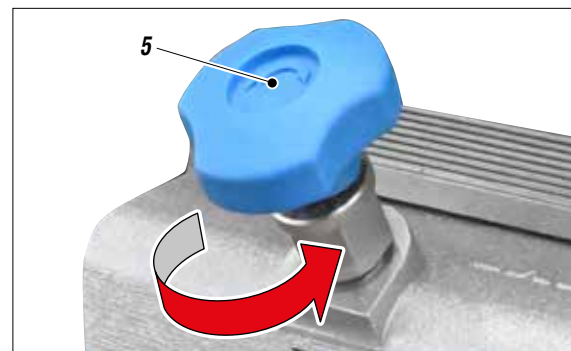

Fig. 4

WARNING :

If the equipment is still under pressure after performing the operations above described because of the nozzle or the flexible hose clogged, proceed as follows:



- Loosen very slowly the gun nozzle.
- Release the clamp.
- Point the gun into the container of the product and press the trigger to release pressure.
- Loosen very slowly the fitting of connection from the flexible hose to the gun.
- Clean or replace the flexible hose and the nozzle.

0 REPLACEMENT OF THE PUMPING GROUP'S GASKETS

- It is recommended to perform this operation after having cleaned the equipment.



Always disconnect the power supply and discharge pressure before performing the following operations (follow the "correct procedure of decompression").

- Use a 19 mm spanner to unscrew the ring nut (1) on the feeding pipe in order to make the operation easier.



Fig. 1

- Release the plastic covering (2).

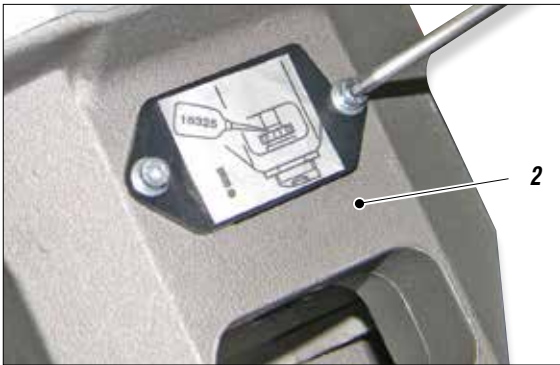

Fig. 2

- Use a screwdriver (3) to turn the motor (4) until the piston stem is at the bottom of its stroke and then move the rod accordingly to remove it.

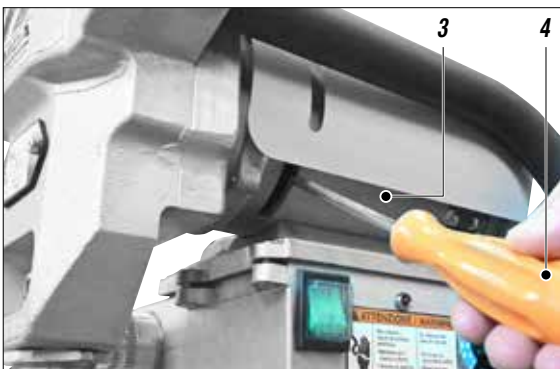

Fig. 3

- Remove the locking pin (5) using pliers (6).



Fig. 4

- Unscrew the fixing ring nut (7), to the end of the thread using a 45 mm spanner.



Fig. 5

- Unscrew the suction casing using a 32 mm spanner as illustrated. If necessary, remove the suction pipe (8) by means of a 19 mm spanner before performing other operations.

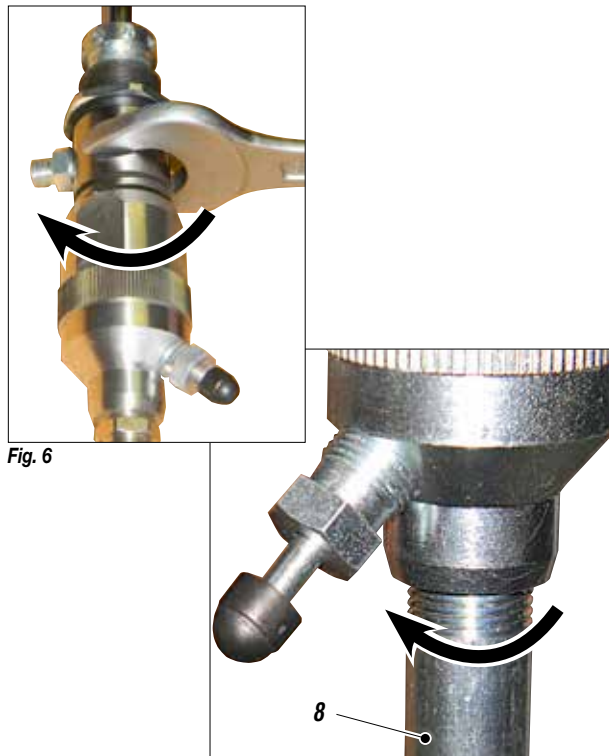

Fig. 6

- Disconnect the pumping group by unscrewing the fastening nut (*wrench 45*).
- Unscrew the pumping group from the housing.

You can now work easily as the pump casing has been freed.

- Grip the complete pump unit (9) in a vice (10) (as shown).

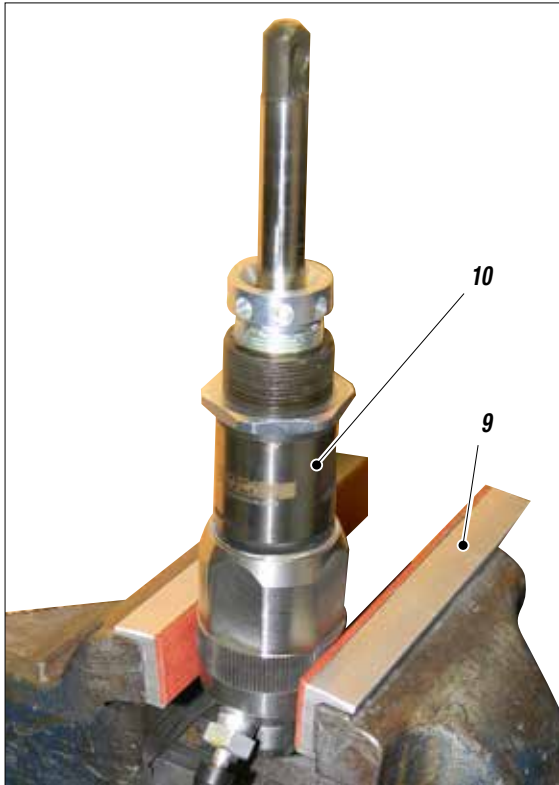

Fig. 7

- Slacken the ring nut (11) by two full turns using the special pin (12) supplied.
Turn anticlockwise as shown.

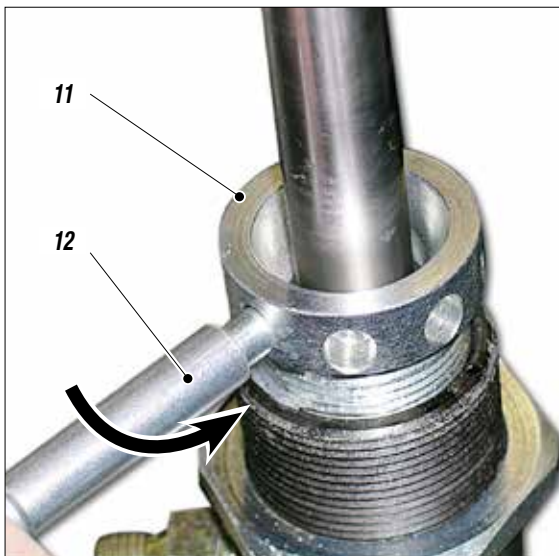

Fig. 8

- Use a 36 mm spanner to unscrew the pump unit as shown.

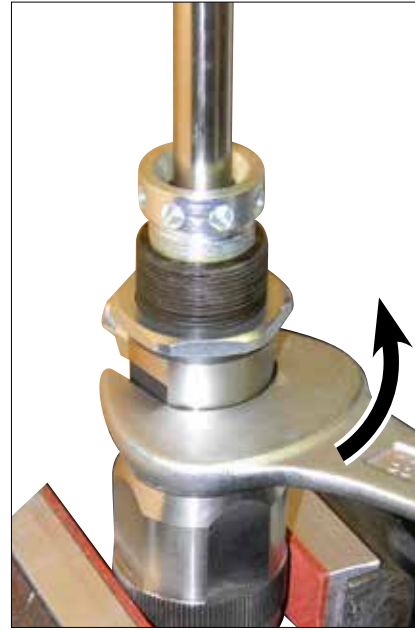

Fig. 9

- Remove the pump unit (13) from the foot valve (14) as shown.
Inspect the two parts separately.

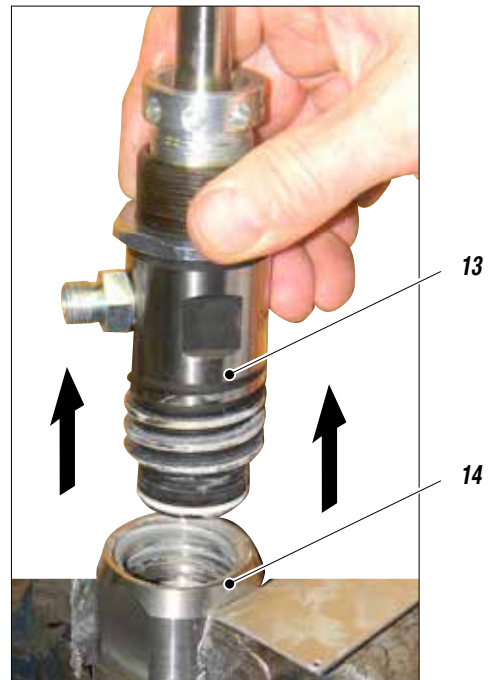

Fig. 10

PIT STOP MAINTENANCE

The replacement of upper and lower will take about 25 minutes.

REPLACING THE FOOT VALVE SEALS

- Replace the PTFE gasket (15) located under the ball housing (16).
- Check that the surfaces of the ball housing (16) and the ball (17) are not damaged. If necessary, replace them both.
- Fit them again using the component sequence as shown.

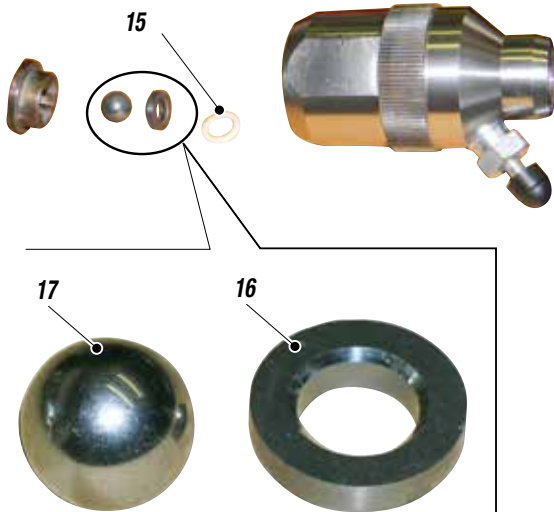

Fig. 11

REPLACING THE PUMP UNIT HOUSING UPPER GASKET

- Remove the piston stem (18) from the pump unit housing (19) as shown.

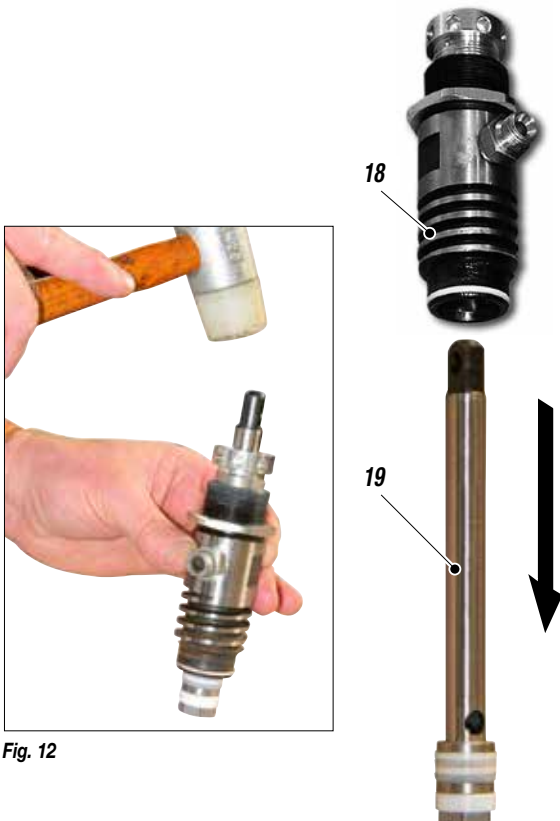

Fig. 12

- Unscrew the gasket ring nut (20) completely.
All the gaskets in the unit must be replaced at the same time to ensure a correct operation of the equipment.

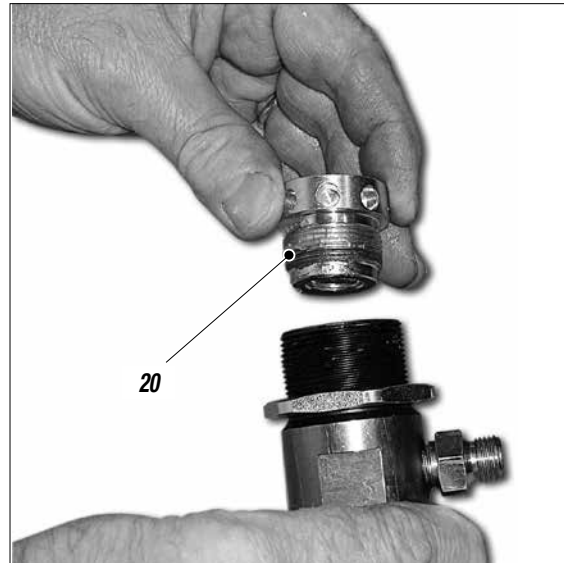

Fig. 13

- Remove the upper stainless steel female ring (21) as shown.

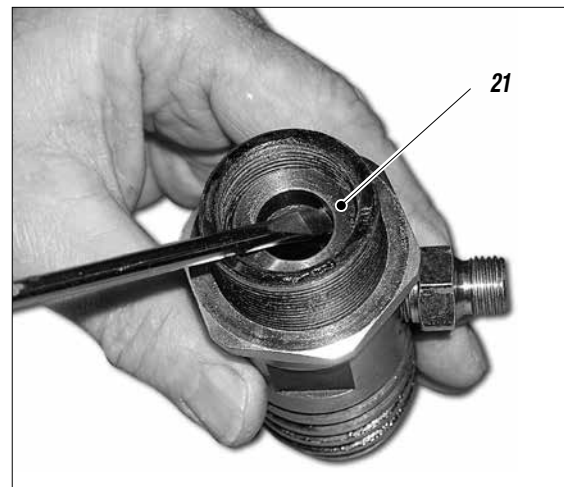

Fig. 14

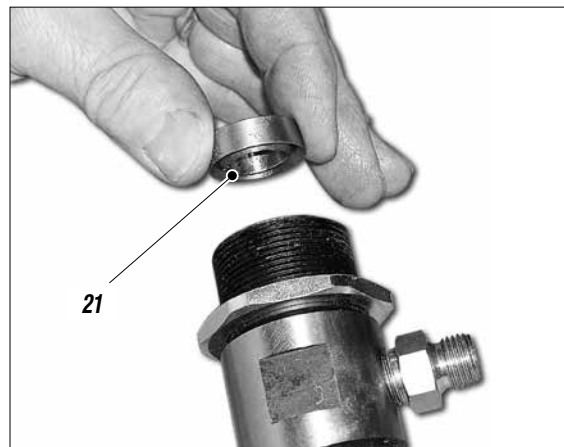
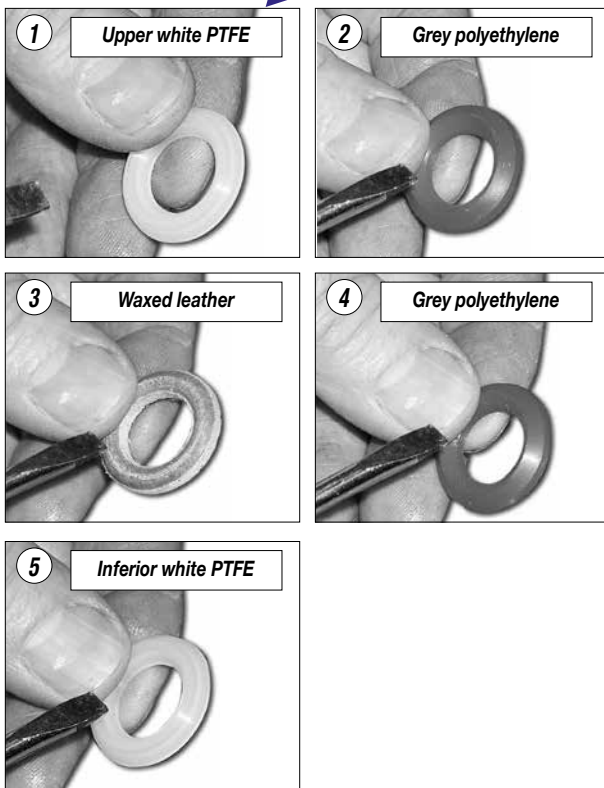

Fig. 15

- Remove the kit of gaskets contained inside the pump unit housing, as shown.



Fig. 16



- Remove the lower stainless steel male ring (22) as shown.

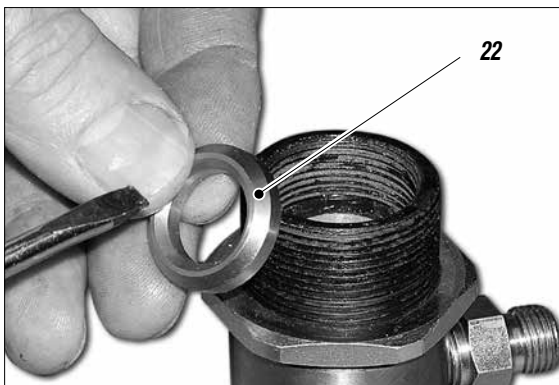

Fig. 17

- Fit the new gasket kit according to the component sequence shown in the picture.

U P P E R

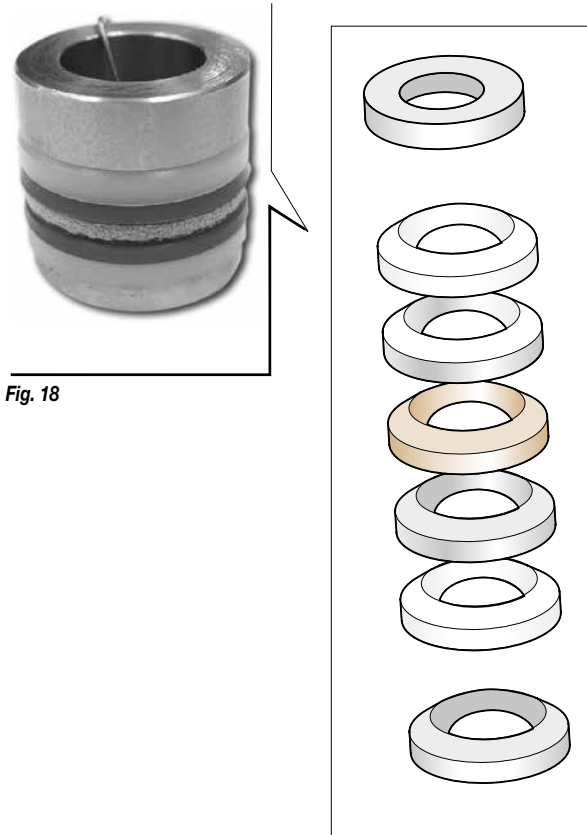
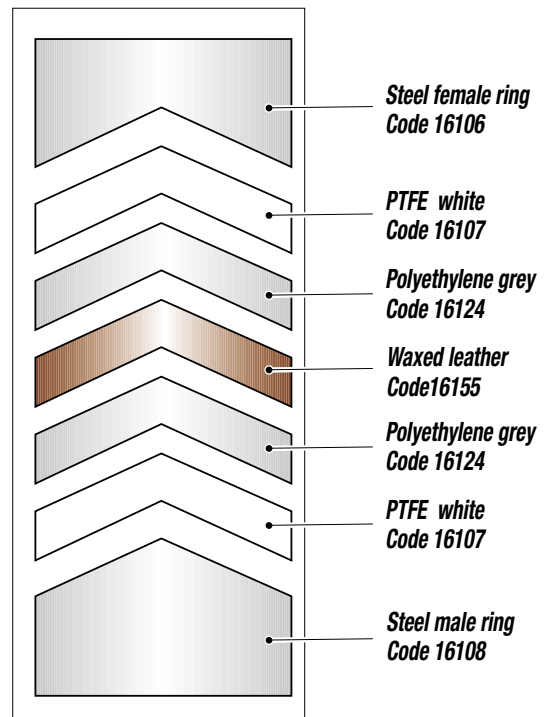

Fig. 18



- Remove the PTFE O-ring (23) and replace it with a new one (24).



Fig. 19

- Use a 10 mm spanner to unscrew and remove the stem (19) as indicated.
- Remove the complete gasket kit (25) from the stem (19), as shown, in order to replace it.

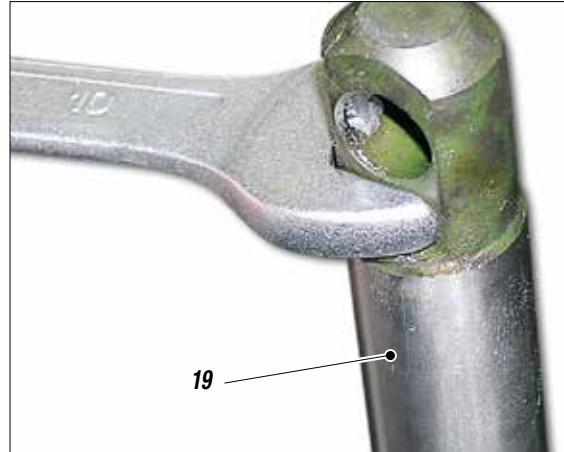

Fig. 21

REPLACING THE PUMP UNIT STEM GASKET

- Secure the stem (19) in a vice as shown.

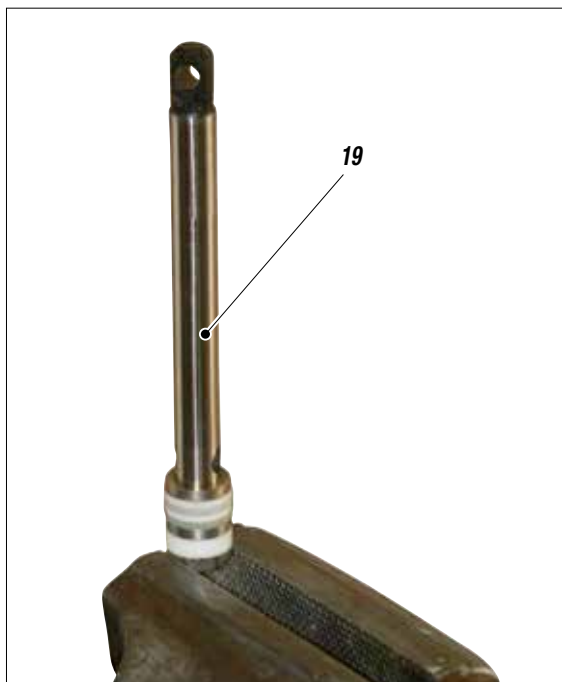

Fig. 20

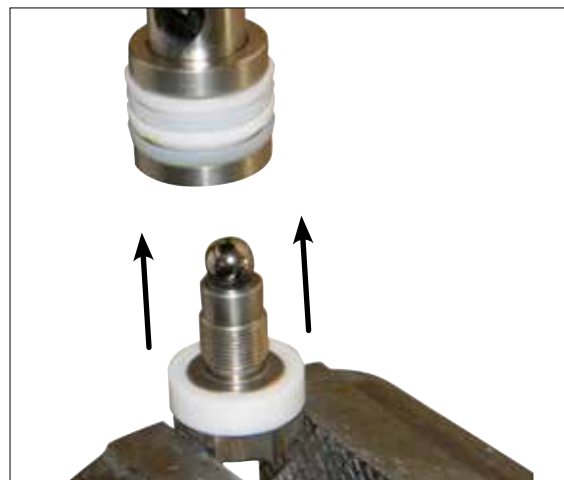

Fig. 22

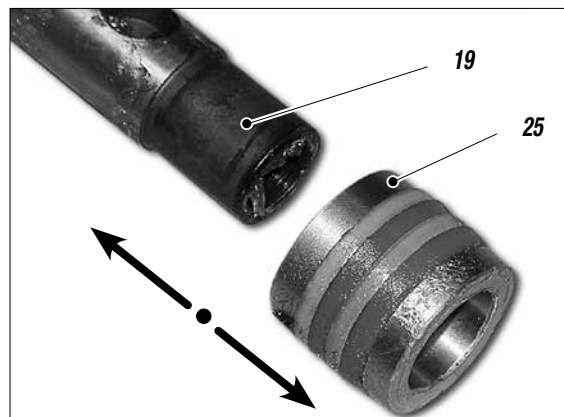

Fig. 23

- Fit the new gasket kit according to the component sequence shown in the picture. Check the scraper for wear (Ref. 18648). Replace if necessary.

L O W E R

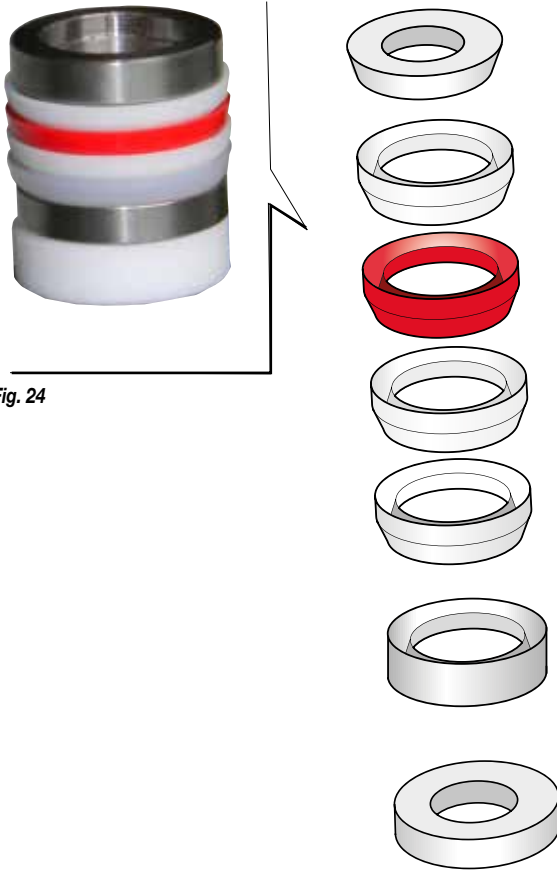
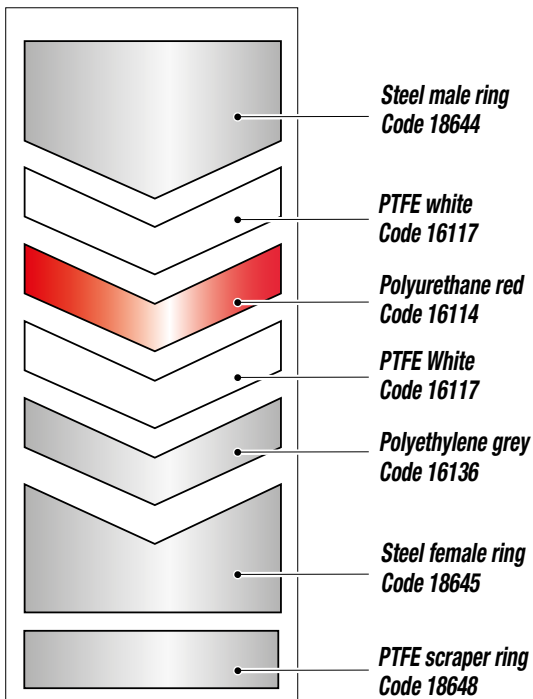

Fig. 24



- Replace the scraper ring (26) of the valve piston, as shown in the picture.
- Check the surfaces of the ball (27) and ball housing (P28), and replace both if damaged.

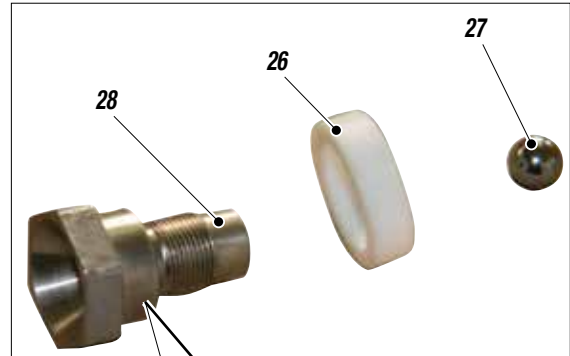
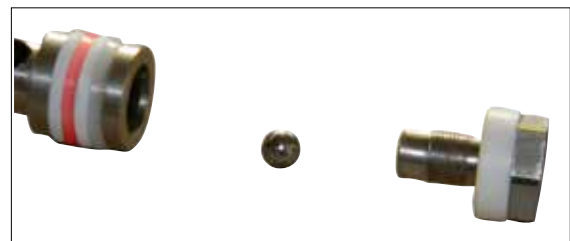

Fig. 25



- Assemble the components as shown.

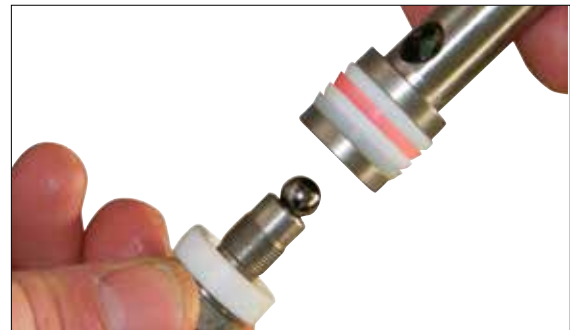

Fig. 26

- Lubricate the gaskets (29) and the stem. Vaseline is recommended for this task.

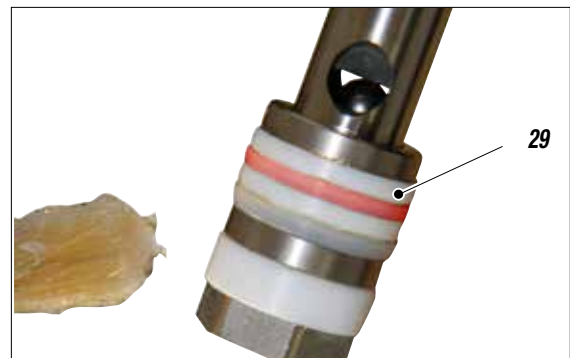

Fig. 27

- Insert the stem (19) into the housing (18) while rotating it in order to allow it to slide more easily and to avoid damaging the upper gaskets.

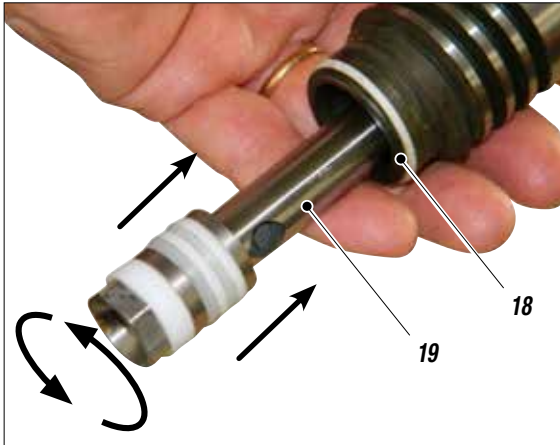

Fig. 28

- Lubricate the O-ring (O30) (Ref. 16126) with grease, as shown. Vaseline is recommended for this task.

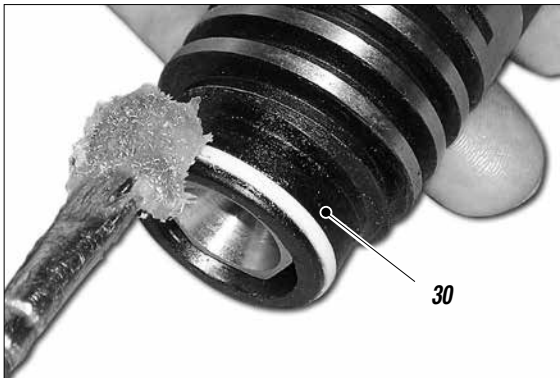

Fig. 29

- Put liquid PTFE on the first two spirals (31) and (32) to avoid the two components coupled as shown from unscrewing.

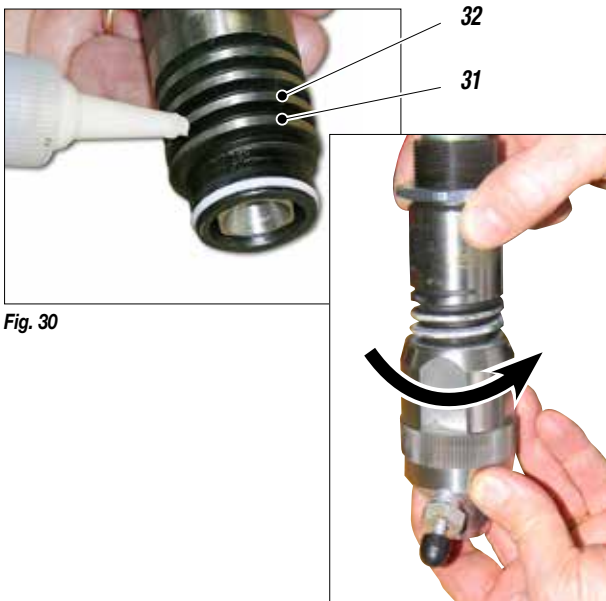

Fig. 30

- Use a 36 mm spanner to screw the pump unit (10).

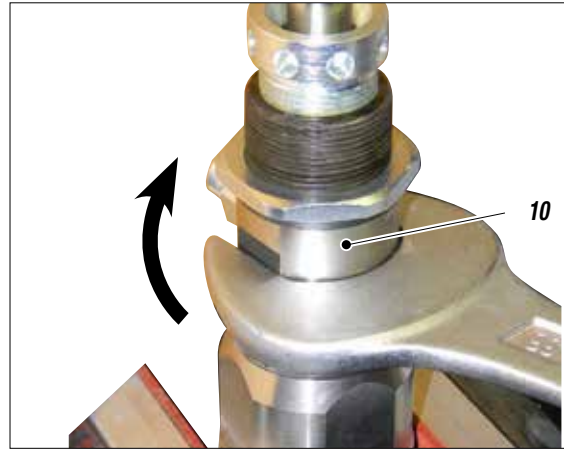

Fig. 31

- Make the piston stem (19) completely slide.

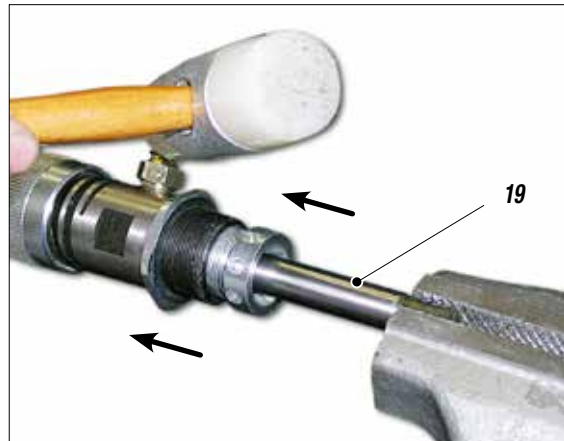

Fig. 32

- Use the pin (12) supplied to tighten the gasket ring nut (11). Close until it is completely tightened, without forcing.

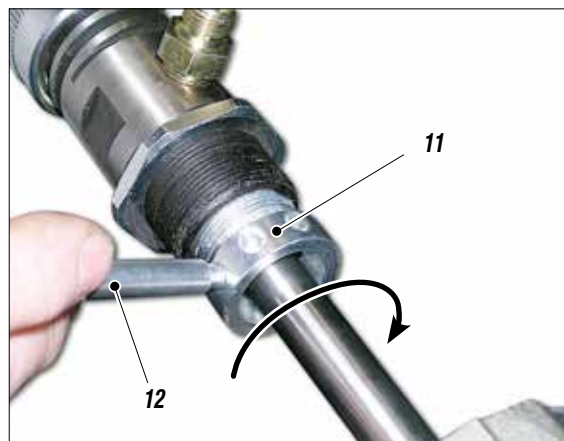

Fig. 33

CORRECT POSITIONING OF THE PUMP UNIT

Once the unit has been refitted, proceed as follows:

- Check the position of the rod, which should be positioned at its lower stopping point.
- Put the pump unit (10) inside the reduction cover (33) as shown.



Fig. 34

- Screw the pump unit onto the front template, making sure that the end of the stem is aligned with the rod groove (34).
- Align the two holes (rod + stem) and insert the stopping pin (35) inside the rod (34).
- Check that the closing spring (36) in the rod (34) is aligned with the pin housing when closed (as shown).



Fig. 35

- Screw the pump unit (10) inside the reduction cover.

- Use a gauge to measure the gap between the base of the template and the tightening groove.



The reference value (see drawing) must be 18 mm. The maximum tolerance accepted for correct operation is 21 mm maximum and 16 mm minimum.

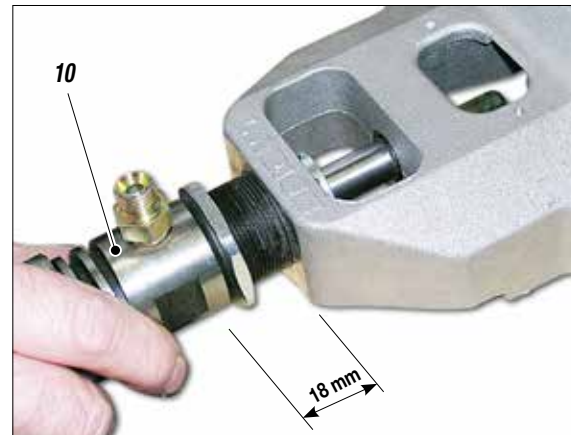

Fig. 36

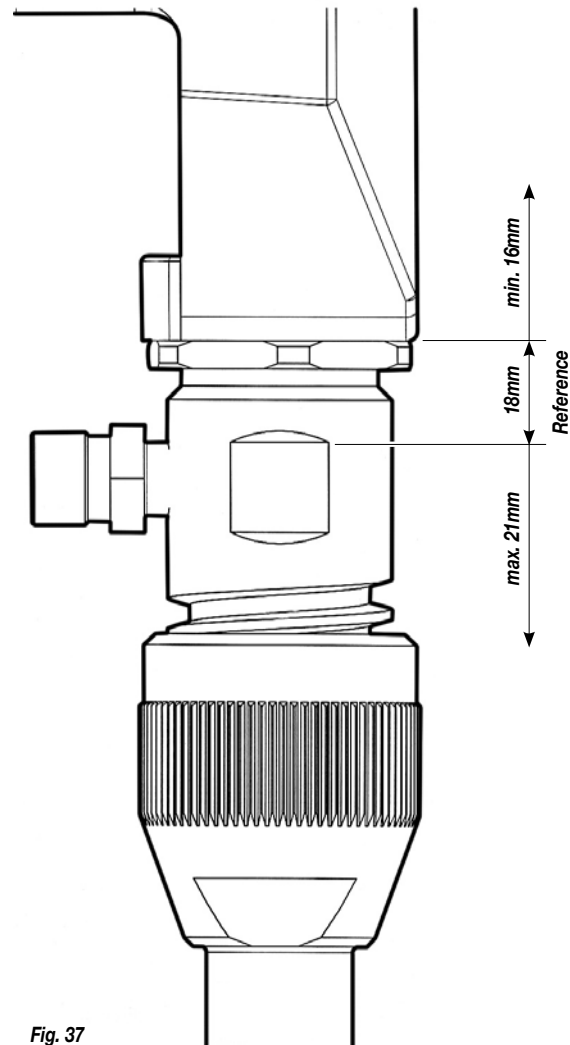

Fig. 37

- Once the unit has been correctly positioned, tighten the lock nut (37) hard against the front template. To tighten, use a 45 mm spanner.

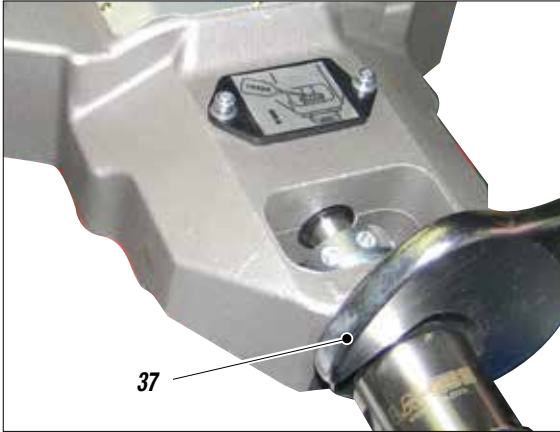

Fig. 38

- Close the inspection cover (2) again.



Fig. 39

- Fit the suction pipe (38). Put PTFE tape or liquid PTFE over the threaded part before screwing it onto the foot valve.

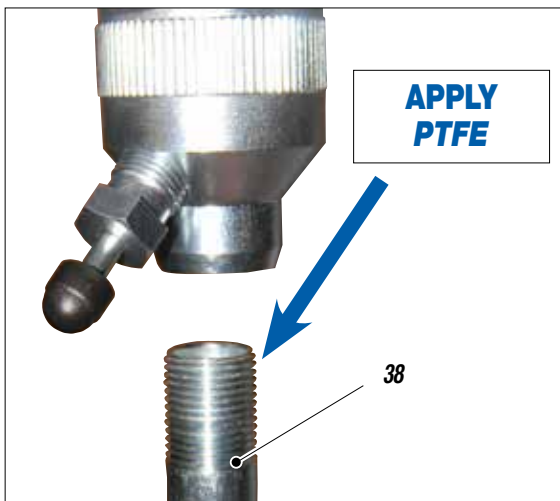



Fig. 40

 For correct reassembly, see the drawing of the pump unit, and follow disassembly operations in reverse order.

REPLACEMENT OF THE BALL RELEASE GROUP SEAL

In case there is a loss of material from the ball release group (39), it is necessary to replace the gasket (40) as shown.

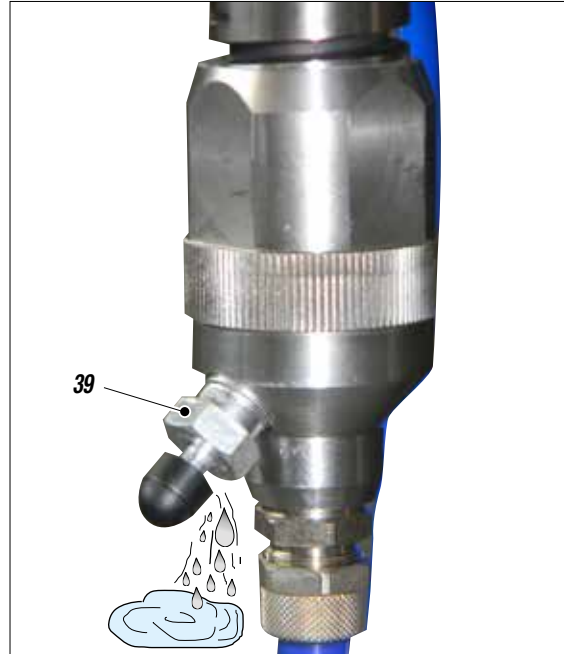

Fig. 41

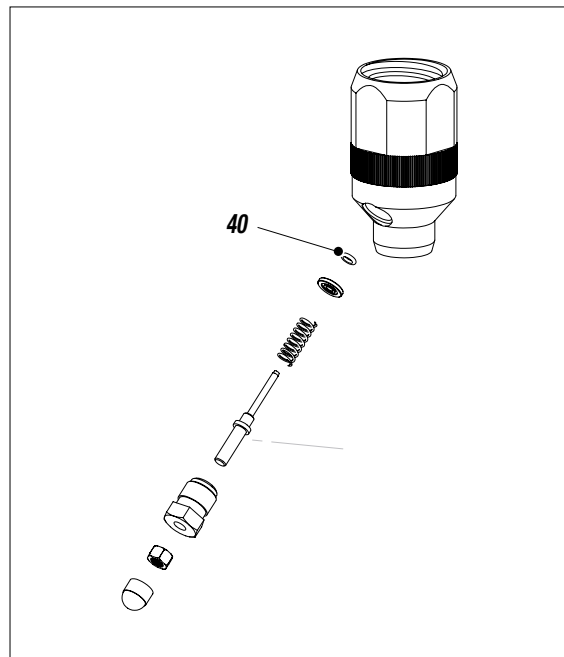

Fig. 42

Q ELECTRIC MOTOR BRUSH REPLACEMENT

WARNING: Always indicate code and quantity for each part required.

BRUSHES CHECK



DISCONNECT THE POWER SUPPLY BEFORE CHECKING OR REPLACING THE BRUSHES.

- Periodically check the wear of the brushes (*at least every 250 working hours*).
- Periodically check the perfect connection among all the electrical components (*at least every 250 working hours*).
- The length of the brush contact must be higher than **7 mm** to guarantee a good working of the rotary group.
- To access the brushes proceed as follows: "A - B - C - D - E".



Fig. 1



Fig. 2



Fig. 3



Fig. 4



Fig. 5

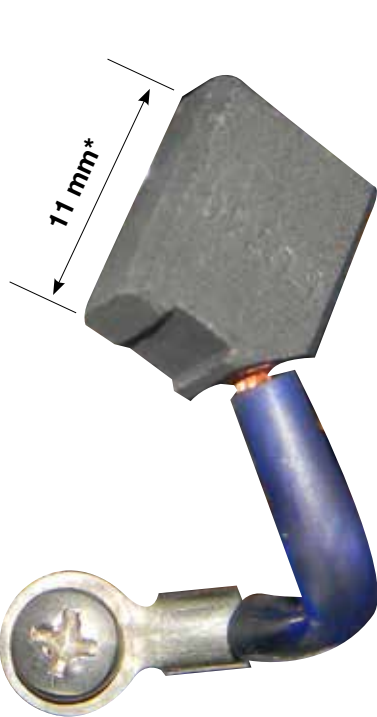
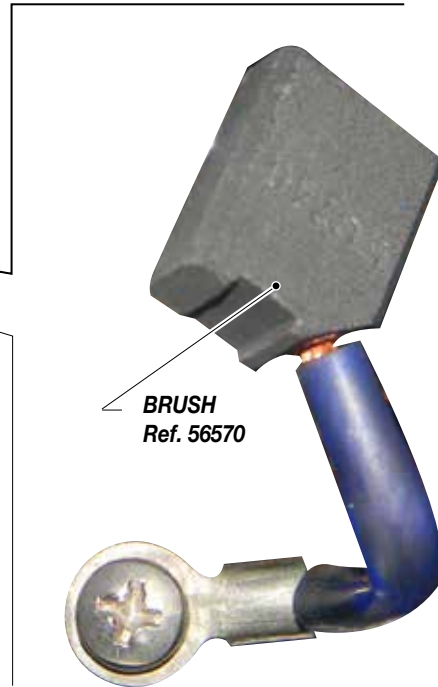

*Length of the new brush

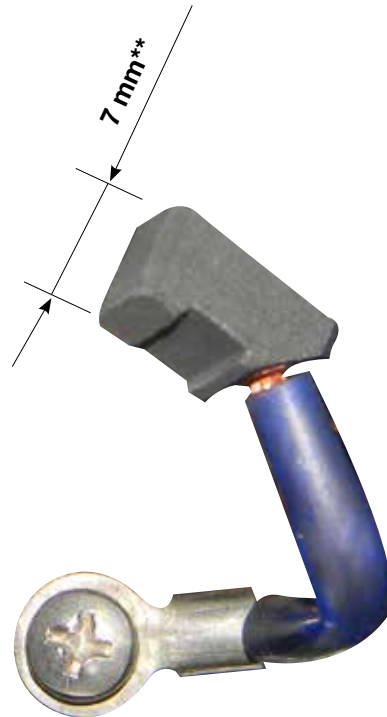

**Minimum length of the brush
REPLACE

Q TROUBLESHOOTING

Problem	Cause	Solution
The equipment does not start	Lack of voltage;	Check the correct connection to the power supply;
	Considerable drops in mains voltage;	Check the extension cable;
	On/Off switch disconnected;	Ensure the On/Off switch is on the “on” position and turn clockwise the pressure control knob;
	Breakdown of pressure transmitter;	Verify and replace it, if necessary;
	Breakdown of motor electric control box;	Verify and replace it, if necessary;
	The line of material coming out of the pump is already under pressure;	Open the drain valve to release pressure in the circuit;
	The product is solidified inside the pump;	Open the drain valve to release pressure in the circuit and stop the machine. Disassemble the pumping group and the pressure transmitter and clean;
The equipment does not suck the product	Suction filter clogged;	Clean or replace it;
	Suction filter too fine;	Replace it with a larger-mesh filter (with very dense products, remove the filter);
	The equipment sucks air;	Check the suction pipe;
	Ball is blocked;	Press the manual unlocking device;
The equipment sucks but does not reach the pressure desired	Lack of product;	Add the product;
	The equipment sucks air;	Check the suction pipe;
	The recirculating-safety valve is open;	Close the recirculating-safety valve;
	The gaskets of the pumping group are worn;	Replace the gaskets;
	Suction or delivery valve dirty;	Disassemble the pumping group;
When pressing the trigger, the pressure lowers considerably	Nozzle too big or worn;	Replace it with a smaller one;
	The product is too dense;	Dilute the product, if possible;
	The filter of the gun-butt is too fine;	Replace it with a larger-mesh filter;
The pressure is normal but the product is not atomized Leakage from the seal-tightening screw	The nozzle is partially clogged;	Clean or replace it;
	The product is too dense	Dilute the product, if possible;
	The filter of the gun-butt is too fine;	Replace it with a larger-mesh filter;
The atomization is imperfect	The nozzle is worn;	Replace it;
When releasing the trigger of the gun, the equipment does not stop (the motor runs slowly and the piston rod moves up and down)	The gaskets of the pumping group are worn;	Replace the gaskets;
	Suction or delivery valve dirty;	Disassemble the pumping group and clean;
	Recirculating-safety valve defective;	Verify and replace it, if necessary;



Always disconnect the equipment and discharge the pressure before performing any check or replacement of pump parts (see “correct procedure of decompression”).

SPARE PARTS version on frame

W Electric motor brush
page 43

R Frame
page 35

S Complete electromechanical
group
page 36

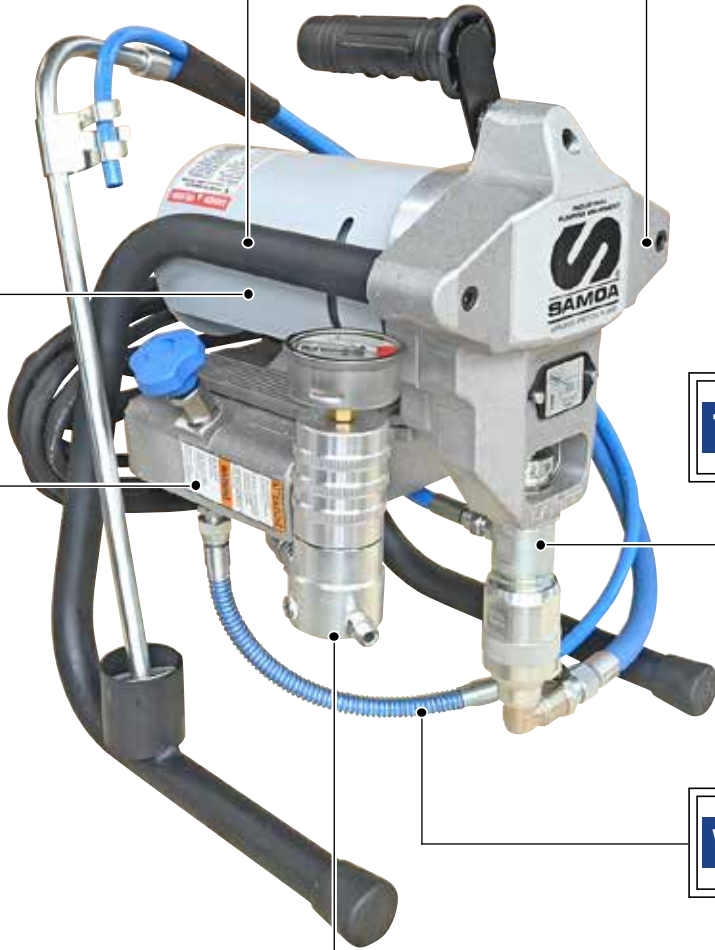

T Complete hydraulic group
page 38

V Suction and recirculation kit
on frame
page 42

U Complete electro-hydraulic
control device
page 40

X Line filter
page 44

SPARE PARTS version on trolley



Y Trolley
page 34

Z Suction and recirculation kit
on trolley
page 36

This page is intentionally left blank

R FRAME REF. 56564

WARNING: Always indicate code and quantity for each part required.

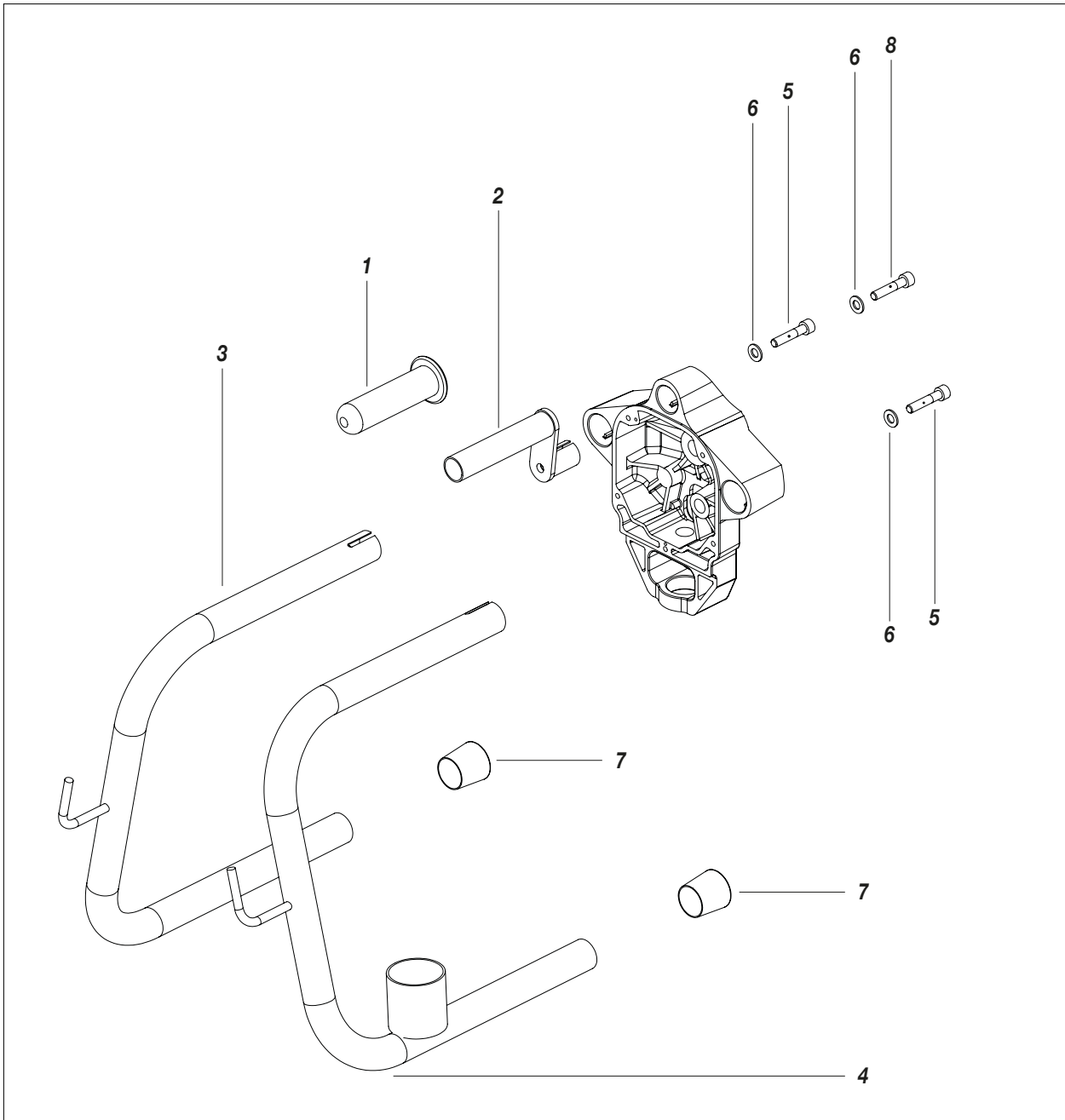

Pos.	Code	Description
-	56564	Frame unit
1	21654	Handle
2	50526	Handgrip
3	56527	Right frame-tube
4	56528	Left frame-tube

Pos.	Code	Description
5	37406	Screw
6	34009	Washer
7	37403	Foot
8	37177	Screw

S COMPLETE ELECTRO-MECHANICAL GROUP REF. 56560 FOR ALL VERSIONS

WARNING: Always indicate code and quantity for each part required.

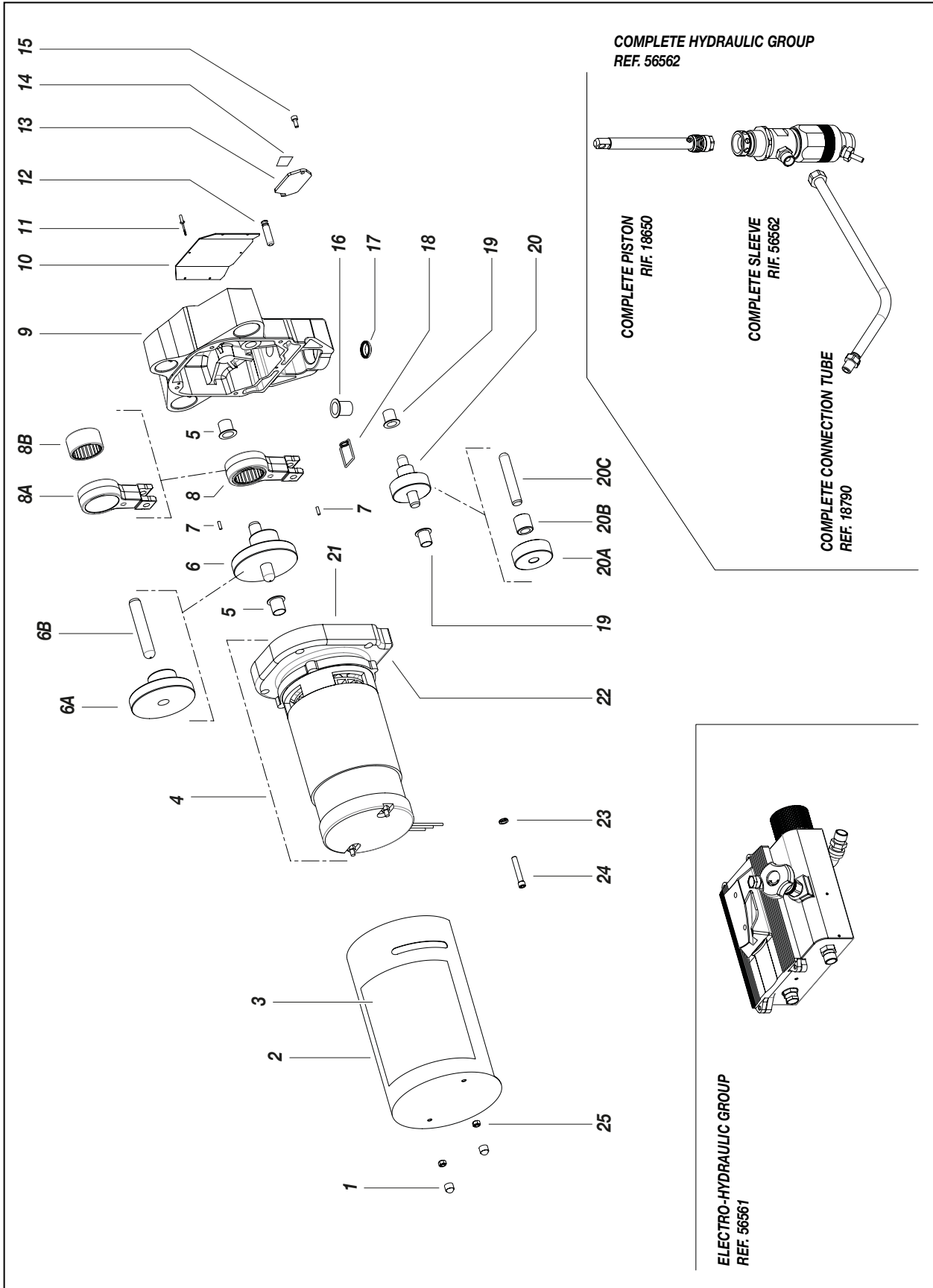

Pos.	Code	Description
-	56560	Complete electro-mechanical group
1	56572	Nut Cover
2	56522	Motor cover
3	56524	Warning label
4	56575	Electric motor 220V 50Hz
	56575/1	Electric motor 110V 50Hz
5	18667	Bushing
6	18672	Complete cam
6A	18670	Notched eccentric
6B	18671	Pin
7	4233	Pin
8	18673	Complete coupling rod
8A	18669	Piston rod
8B	18668	Bearing
9	18663	Reduction cover
10	56523	Front plate
11	34021	Rivet Ø 2 mm

Pos.	Code	Description
12	18666	Pin
13	18674	Safety cover
14	18677	Label
15	5378	Screw
16	18664	Rod bushing
17	18685	Ring
18	18665	Spring
19	18681	Transmissione bushing
20	18680	Complete transmission
20A	18676	Notched wheel
20B	18678	Pinion gear
20C	18679	Pin
21	56521	Drive shaft
22	56520	Motor flange
23	34009	Washer
24	8029	Screw
25	33024	Nut

T COMPLETE HYDRAULIC GROUP REF. 56562

WARNING: Always indicate code and quantity for each part required.

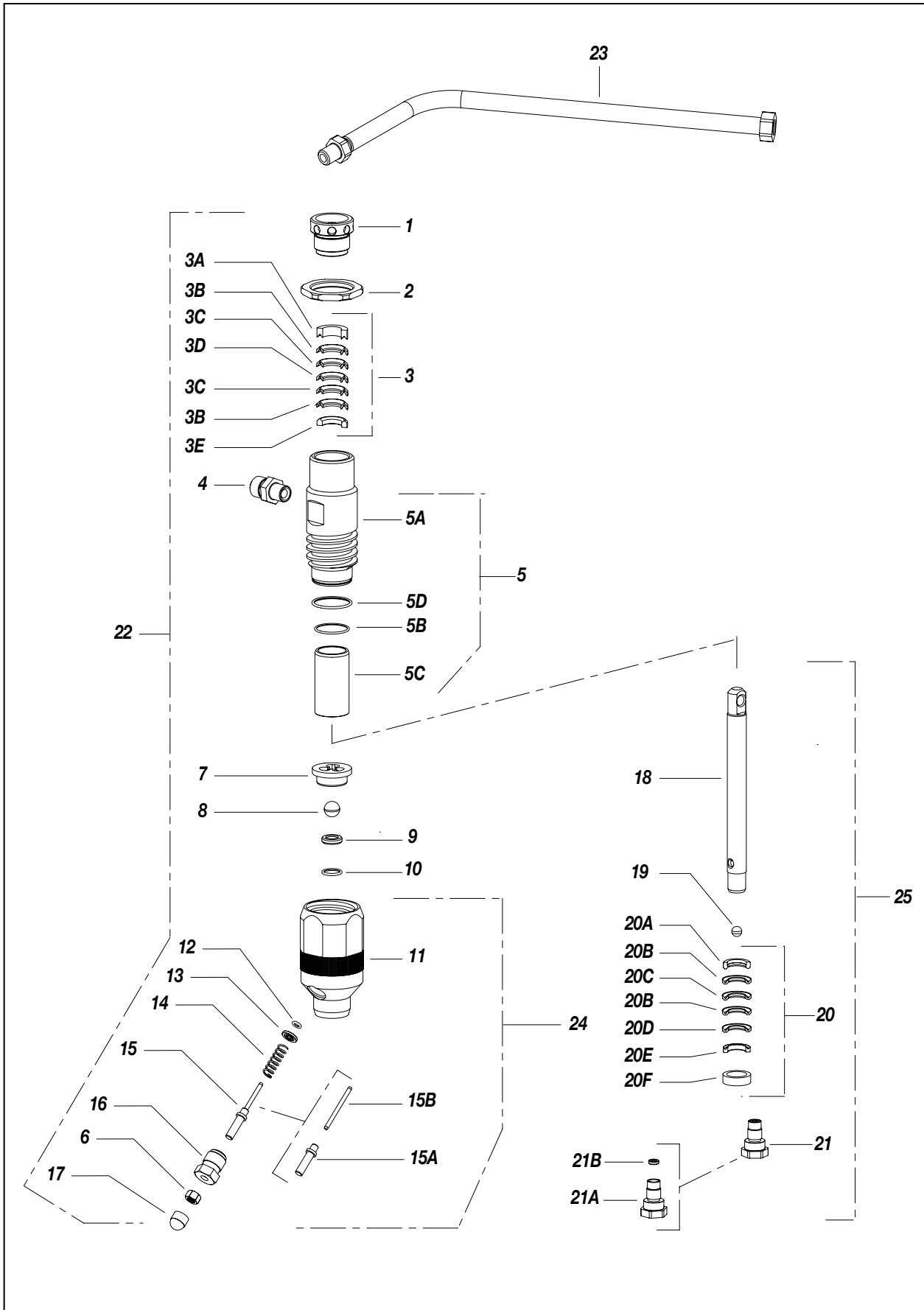

Pos.	Code	Description
-	56562	Complete hydraulic group
1	16109	Ring packing
2	16127	Locking nut
3	16105	Upper gaskets kit
3A	16106	Ring
3B	16107	PTFE gasket
3C	16124	Polyethylene gasket
3D	16155	Waxed leather gasket
3E	16108	Ring
4	96208/1	Fitting
5	18640	Complete pumping unit
5A	18640/1	Pumping unit
5B	18640/3	ORm
5C	18640/2	Sleeve
5D	16126	OR
6	91026	Nut M6
7	18642	Ball guide
8	33028	Ball ø 11mm
9	91018	Ball housing
10	18643	ORM
11	56536	Foot valve body
12	18553	OR
13	56540	Disk

Pos.	Code	Description
14	9288	Spring
15	56547	Releasing rod complete
15A	56539	Command rod
15B	56537	Releasing rod
16	56538	Guiding bushing
17	56541	Nut M6 stopper
18	18652	Piston rod
19	16130	Ball ø 5/16"mm
20	18651	Lower gaskets kit
20A	18644	Ring
20B	16117	Gasket
20C	16114	Red Gasket
20D	16136	Polyethylene Gasket
20E	18645	Ring
20F	18648	Ring
21	18655	Complete rod valve
21A	18646	Rod valve
21B	7154	Ball housing
22	56565	Complete hydraulic sleeve
23	18790	Complete connection tube
24	56526	Valve body and releasing rod complete
25	18650	Complete hydraulic rod

**Complete pump repair kits
COD. 40107**

Pos.	Descrizione
3	Upper gaskets kit
5A	Pumping unit
5D	Sleeve
8	Ball ø 11mm
10	ORM
18	Piston rod
19	Ball ø 5/16"mm
20	Lower gaskets kit

**Pump maintenance kit
COD. 40106**

Pos.	Descrizione
3	Upper gaskets kit
5D	Sleeve
8	Ball ø 11mm
10	ORM
18	Piston rod
19	Ball ø 5/16"mm
20	Lower gaskets kit

**Foot valve kit
COD. 18854**

Pos.	Descrizione
8	Ball ø 11mm
9	Ball housing
10	ORM

**Gasket kit lower + higher
COD. 18855**

Pos.	Descrizione
3	Upper gaskets kit
20	Lower gaskets kit

U COMPLETE ELECTRO-HYDRAULIC DRIVING GROUP REF. 56561 FOR ALL VERSIONS

WARNING: Always indicate code and quantity for each part required.

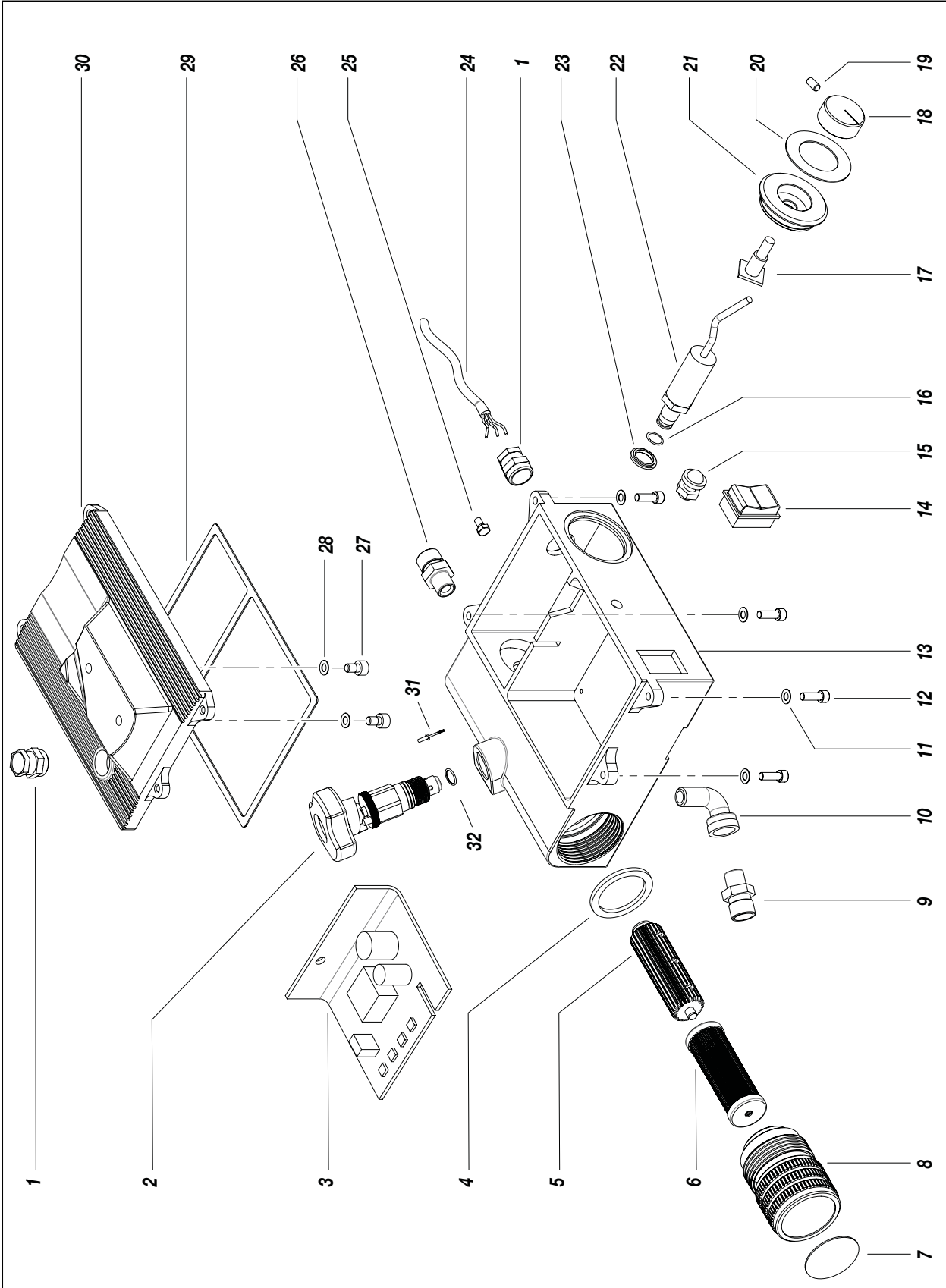

Pos.	Code	Description
-	56561	Complete electro-hydraulic group
1	18871	Cable fastener
2	56563	Valve
3	56530	Electronic card
4	56535	Gasket
5	18627	Sieve support
6	16205	Filter sieve
7	18657	Pressure label
8	56534	Filter cap
9	96206	Fitting
10	18614	Fitting
11	5737	Washer
12	4019	Screw
13	56533	Electro-hydraulic box
14	5933	Switch
15	56548	Signal LED
16	18689	OR ring

Pos.	Code	Description
17	18693/1	Potentiometer
18	20349	Adjusting knob
19	95210	Hex socket set screw
20	18687	Pressure label
21	18682	Plug
22	18692	Pressure sensor
23	18684	Gasket
24	18870	Power cable
25	20245	Screw
26	96208/1	Fitting
27	5727	Screw M6x8
28	32005	Washer ø6
29	18625	Gasket
30	18654	Box cover
31	34021	Rivet
32	8402	OR 2087



The Manufacturer declines all responsibility for any damage or malfunction of the machine following tampering or alteration of the valve calibration.



Equipped with:

MATERIAL HOSE 1/4" - M16x1,5
Art. 18026: 15 mt

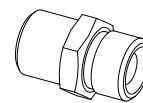

For a 1/4" fitted gun, you need:

ADAPTER
Art. 3276

V SUCTION AND RECIRCULATION KIT ON FRAME RIF. 56567

WARNING: Always indicate code and quantity for each part required.

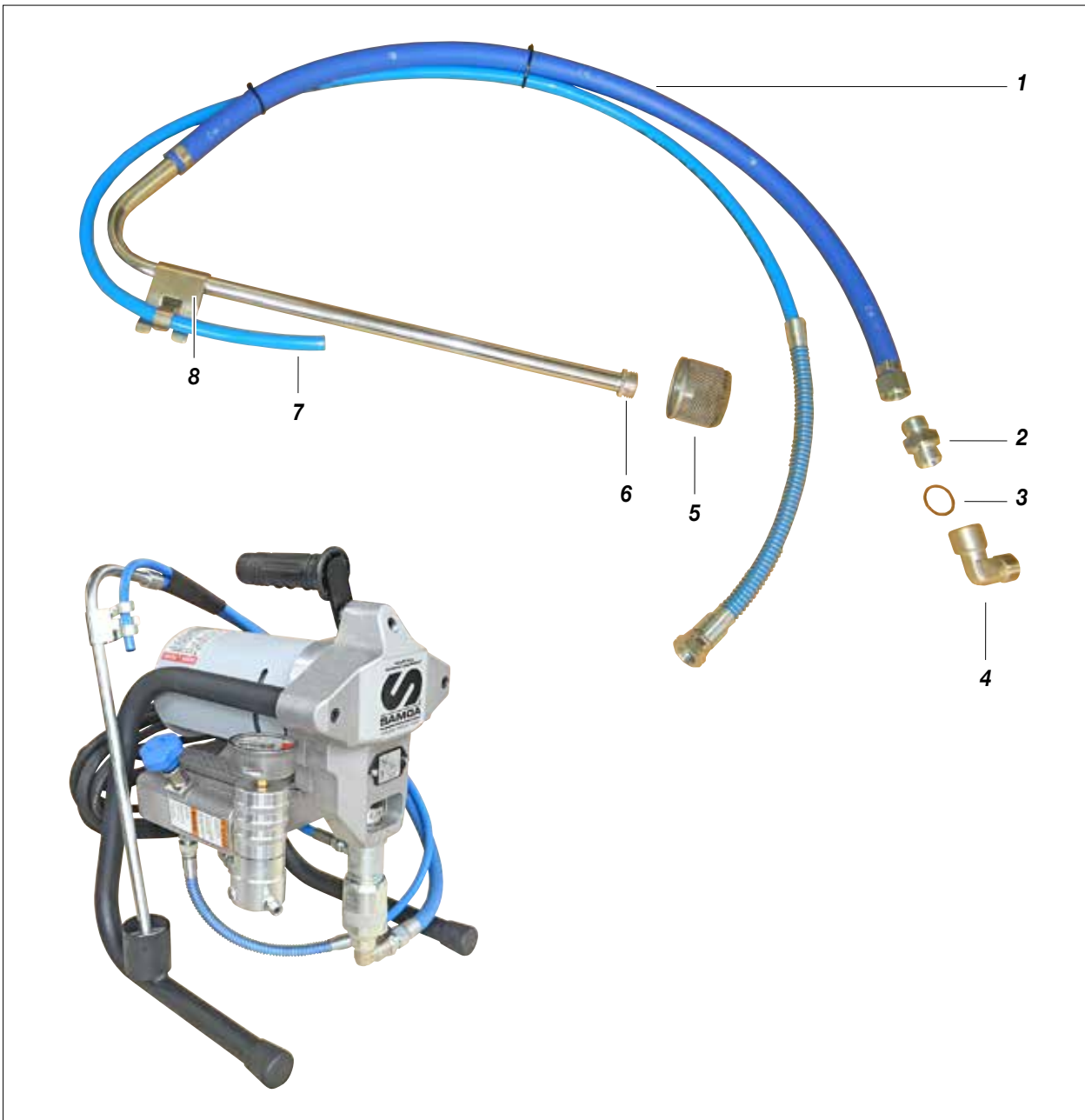

Pos.	Code	Descripton
-	56567	Complete suction-recirculation kit
1	56569	Suction tube
2	8058	Nipple 1/2"
3	8071	asket 1/2"
4	20811	Elbow M-F
5	16802	Filter
6	56542	Filter fitting
7	56573	Reciculation hose
8	18094	Spring

Pos.	Code	Descripton
-	56571	Suction-recirculation group
1	56569	Suction tube
5	16802	Filter
6	56542	Filter fitting
7	56573	Reciculation hose
8	18094	Spring

W ELECTRIC MOTOR BRUSH

WARNING: Always indicate code and quantity for each part required.

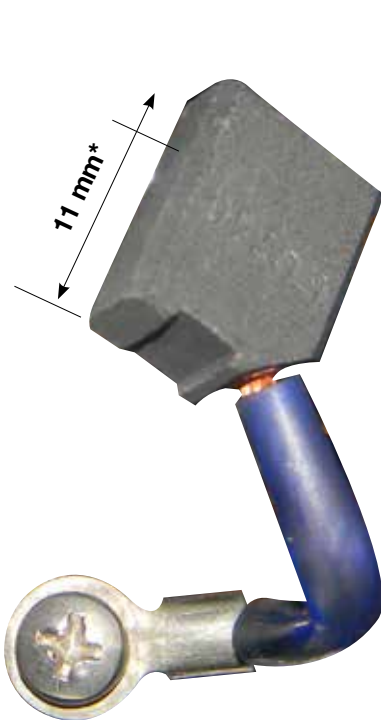
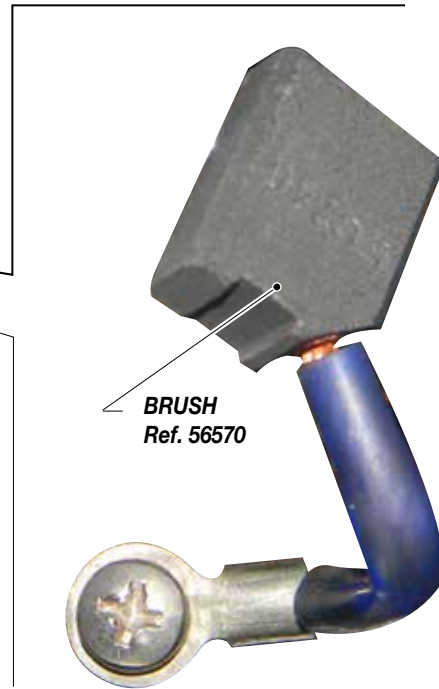

*Length of the new brush

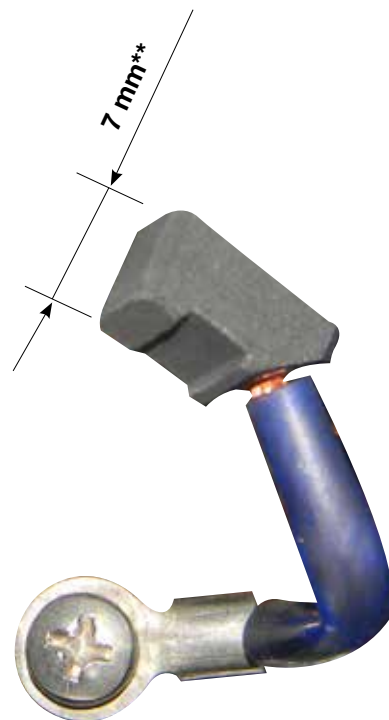

**Minimum length of the brush
REPLACE

X LINE FILTER

WARNING: Always indicate code and quantity for each part required.

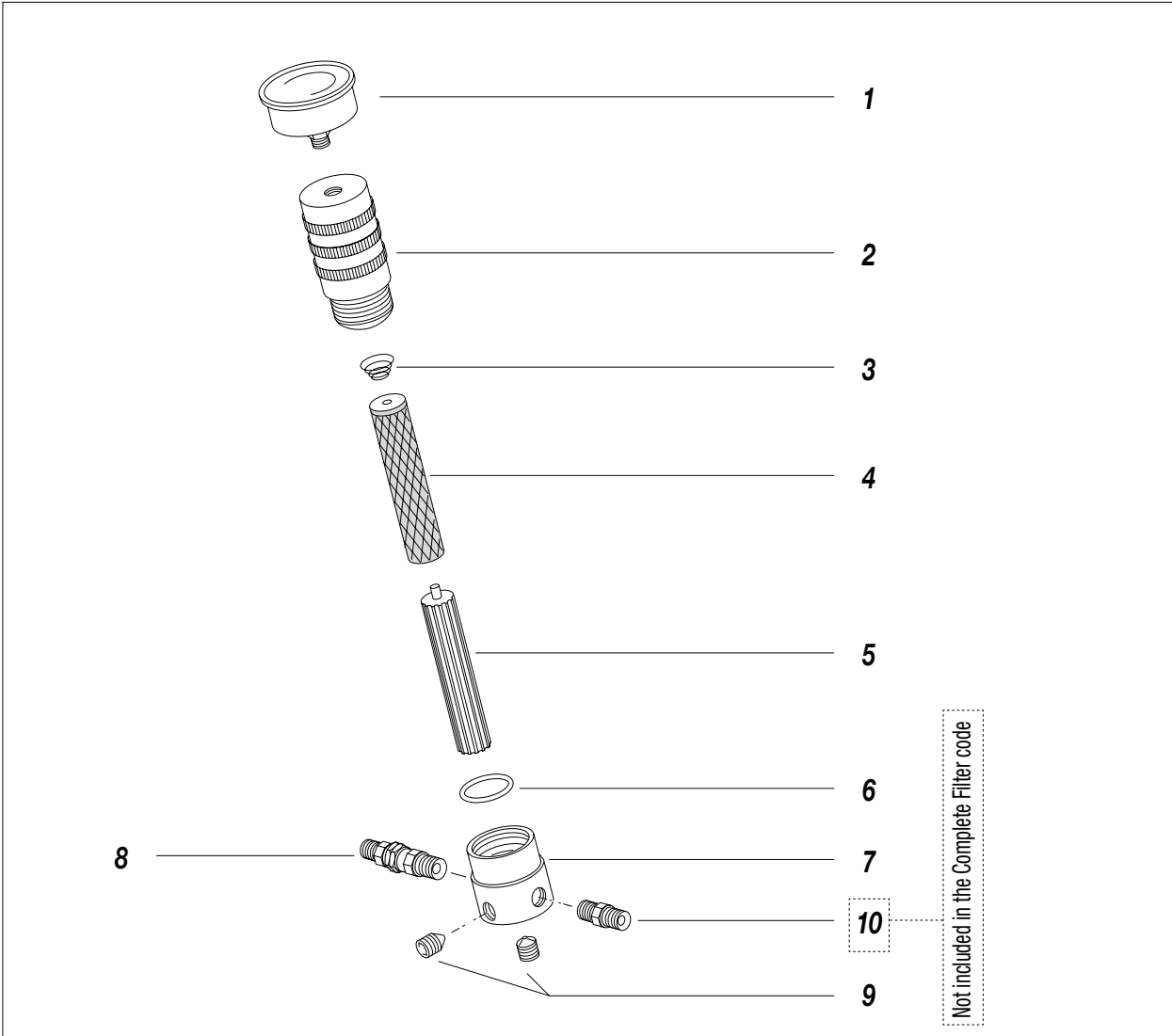

Pos.	Code	Description	Q. ty
	200432	Complete filter	
1	53011	Manometer	1
2	16201	Filter tank (suction)	1
3	96202	Filter sieve spring	1
4	16205	Filter sieve 60 M	1
5	16202	Filter sieve support	1
6	96203	O ring	1
7	96204	Filter base	1
8	3279	Revolving fitting	1
9	96205	Plug 1/4" GAS	2

Not included in the Complete Filter code

Pos.	Code	Description	Q. ty
10	19620	Nipple 1/4 NPSM	1
	96206	Nipple M16x1,5	1

Y TROLLEY REF. 56555

WARNING: Always indicate code and quantity for each part required.



Pos.	Codice	Description
1	21654	Handle
2	18631	Handgrip
3	37406	Screw
4	34009	Washer
5	91047	Wheel washer

Pos.	Codice	Description
6	37218	Wheel
7	18635	Frame
8	95159	Caps
9	37177	Screw

Z SUCTION AND RECIRCULATION GROUP ON TROLLEY RIF. 56568

WARNING: Always indicate code and quantity for each part required.

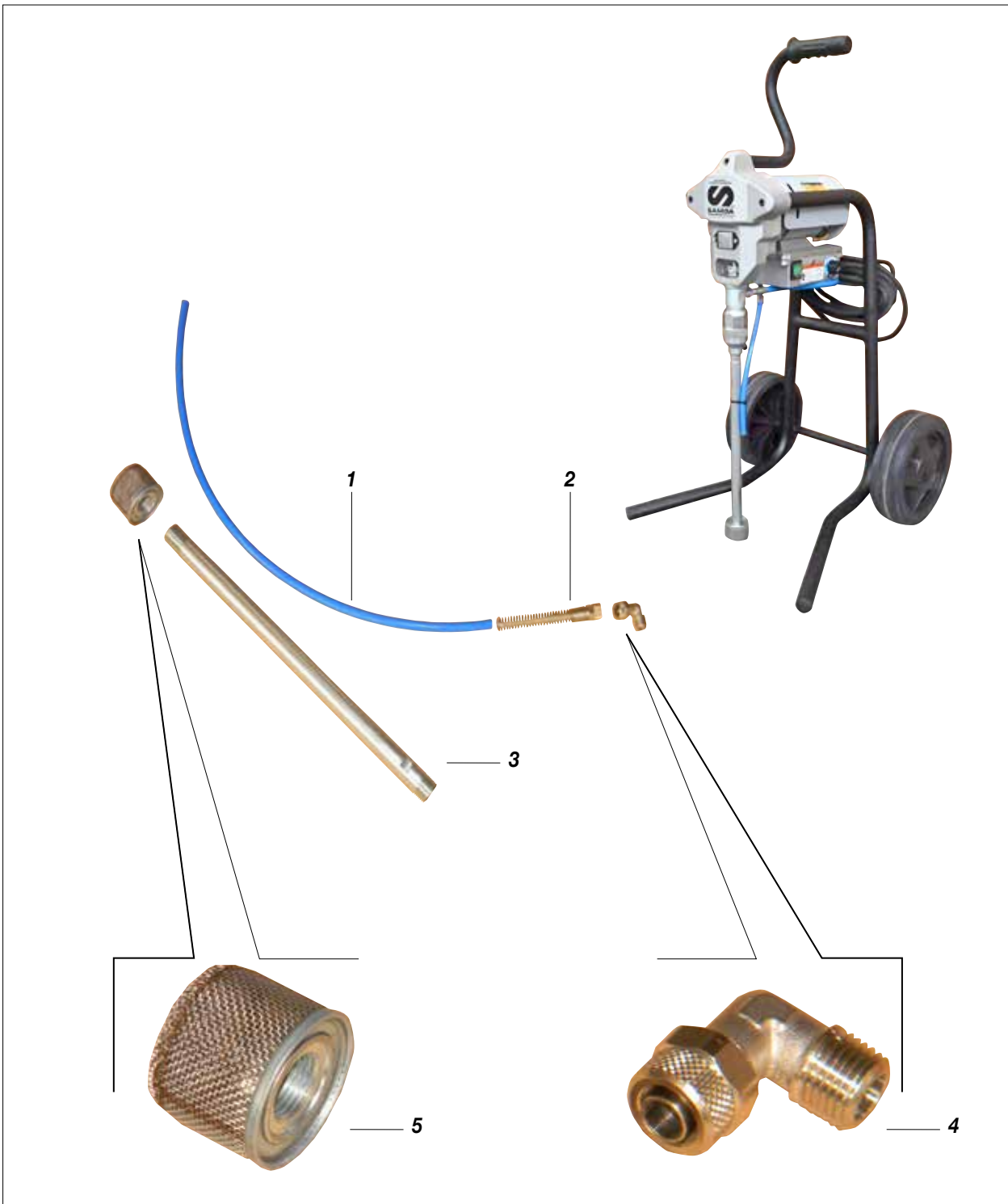

Pos.	Code	Description
-	56568	Complete suction-recirculation group
1	18170	Rilsan hose
2	16066	Nut with spring
3	8046	Tube

Pos.	Code	Description
4	4011	Fitting
5	16802	Filter



CE DECLARATION OF CONFORMITY



Company



LARIUS srl
Via Antonio Stoppani 21 - 23801 Calolziocorte (LC) ITALY
Tel: +39 0341 621152
Fax: +39 0341 621243
E-mail: larius@larius.com

Declares under his owns responsibility that the product:

JOLLY Electric piston pump

complies with the directives:

- EC Directive 2006/42 Machinery Directive
- EU Directive 2014/30 Electromagnetic Compatibility (EMC)
- EU Directive 2014/35 Low Voltage (LVD)

furthermore to the
harmonized standards:

- UNI EN ISO 12100-1/-2
Machinery safety, basic concepts, general principles of design. Basic terminology, methodology. Technical principles.

This declaration relates exclusively to the product in the state in which it was placed on the market, and excludes components or modifications which are added or carried out subsequently by end user.

Signature

Pierangelo Castagna
Managing Director

Calolziocorte, 11 November 2024
Location / Date



SAMOA INDUSTRIAL, S.A. - HEADQUARTERS
SPAIN AND EXPORT MARKETS
 POL. IND. PORCEYO, I-14 - CAMINO DEL FONTÁN, 831
 E-33392 GIJÓN (ASTURIAS), SPAIN
 TEL.: +34 985 381 488 - FAX: + 34 985 147 213

SAMOA S.A.R.L.
FRANCE
 P.A.E.I. DU GIESSEN
 3, RUE DE BRISCHBACH
 67750 SCHERWILLER, FRANCE
 TEL.: +33 3 88 82 79 62 - FAX: +33 3 88 82 77 88

SAMOA ITALIA - LARIUS
ITALY
 VIA ANTONIO STOPPANI,21
 23801 CALOLZIOCORTE (LC) ITALY
 Tel.: +39 0341 621152 - Fax: + 39 0341 621242

SAMOA FLOWTECH GMBH
 GERMANY, AUSTRIA, SWITZERLAND, THE NETHERLANDS AND GREECE
 AM OBEREICHHOLZ 4
 D - 97828 MARKTHEIDENFELD, GERMANY
 TEL.: +49 9391 9826 0 - FAX: +49 9391 98 26 50





SAMOA LTD.
UNITED KINGDOM AND REP. OF IRELAND
 ASTURIAS HOUSE - BARRS FOLD ROAD
 WINGATES INDUSTRIAL PARK
 WESTHOUGHTON, BL5 3XP, UK
 TEL.: +44 1942 850600 - FAX: +44 1942 812160

SAMOA CORPORATION
 USA AND CANADA
 90 MONTICELLO ROAD
 WEAVERVILLE, NC 28787, USA
 TEL. +1 (828) 645-2290 - FAX: +1 (828) 658 0840



©Copyright, SAMOA INDUSTRIAL, S.A.
 SAMOA Industrial, S.A. is an ISO 9001, ISO 14001 and ISO 45001 certified company.

»»» Contact us today!
 Visit www.samoaindustrial.com for more information.

OPERATING AND MAINTENAINCE MANUAL AVAILABLE IN:		
	IT	https://www.larius.com/wp-content/uploads/JOLLY_I.pdf
	EN	https://www.larius.com/wp-content/uploads/JOLLY_GB.pdf
	DE	https://www.larius.com/wp-content/uploads/JOLLY_D.pdf
	FR	https://www.larius.com/wp-content/uploads/JOLLY_F.pdf
	ES	https://www.larius.com/wp-content/uploads/JOLLY_E.pdf