



www.larius.com

EVEREST TH LINER

Horizontal Street Marking

INSTRUCTION MANUAL



- | | |
|----|---|
| IT | https://www.larius.com/wp-content/uploads/EVERESTLINER_I.pdf |
| EN | https://www.larius.com/wp-content/uploads/EVERESTLINER_GB.pdf |
| DE | https://www.larius.com/wp-content/uploads/EVERESTLINER_D.pdf |
| FR | https://www.larius.com/wp-content/uploads/EVERESTLINER_F.pdf |
| ES | https://www.larius.com/wp-content/uploads/EVERESTLINER_SP.pdf |
| PL | https://www.larius.com/wp-content/uploads/EVERESTLINER_PL.pdf |



This manual is to be considered as an English language translation of the original manual in Italian. The manufacturer shall bear no responsibility for any damages or inconveniences that may arise due to the incorrect translation of the instructions contained within the original manual in Italian.

Due to a constant product improvement programme, the factory reserves the right to modify technical details mentioned in this manual without prior notice.

EVEREST TH LINER

Self-propelled professional line-marker

INDEX













WARNINGS	p.2	M CHARGING THE BATTERY	p.20
A WORKING PRINCIPLE.....	p.3	N ROUTINE MAINTENANCE.....	p.21
B TECHNICAL DATA.....	p.4	Check the packing nut.....	p.21
Application fields	p.5	Pressure switch seal check.....	p.22
Nozzle position table	p.5	Checking the motor oil	p.22
C DESCRIPTION OF THE EQUIPMENT.....	p.6	O DESCRIPTION OF THE CONTROLS	p.23
D TRANSPORT AND UNPACKING	p.10	P EVEREST LINER CONTROL PANEL USE.....	p.24
E SAFETY RULES.....	p.10	Q LINE SEQUENCING FUNCTION.....	p.26
CONDITIONS OF GUARANTEE.....	p.10	R SPACE AND LINE SETTINGS	p.29
F SETTING-UP	p.11	S PROBLEMS AND SOLUTIONS.....	p.31
Connection of the guns.....	p.11	T CORRECT PROCEDURE OF DECOMPRESSION.....	p.32
Connection of the manual gun.....	p.12	U REPLACEMENT OF THE PUMPING GROUP	
Washing of the new equipment.....	p.12	GASKETS	p.33
Preparation of the paint.....	p.13	Pit stop maintenance.....	p.34
G WORKING	p.14	Lower seal	p.34
Setup procedure	p.14	Upper seal	p.36
Adjusting pump unit speed	p.15	SPARE PARTS	
H PAINTING OPERATIONS	p.15	V COMPLETE SHORT PUMPING ELEMENT	p.42
Spray adjustment.....	p.16	W LINER TYPE MACHINES	p.43
I APPENDIX "A": UNIT WITH PEARLIZED		X REDUCTION UNIT.....	p.46
REFLECTING PAINT DISTRIBUTION		Y HIGH PRESSURE GUN "AT 250"	p.47
ACCESSORY	p.17	Z SPRAY GUN EXPLODED VIEW LA95 REF. 23340/4 ...	p.48
Description of the equipment.....	p.17	AA FLOW COMPENSATOR	p.49
J REGULATIONS.....	p.17	AB BASIC HYDRAULIC BLOCK REF.30400	p.50
Adjusting the guns.....	p.17	AC THE BATTERY GROUP	p.51
Adjusting the distribution unit.....	p.18	AD 50L TANK.....	p.52
Adjusting the pneumatic system pressure	p.18	AE ELECTRONIC BOARD	p.53
CLEANING AT THE END OF THE WORK.....	p.18	AF ACCESSORIES.....	p.54
K GENERAL MAINTENANCE	p.20		
L Daily.....	p.20	CE DECLARATION OF CONFORMITY.....	p.59
Periodically.....	p.20		

**WE ADVISE THE USE OF THIS EQUIPMENT ONLY BY PROFESSIONAL OPERATORS.
 ONLY USE THIS MACHINE FOR USAGE SPECIFICALLY MENTIONED IN THIS MANUAL.**

Thank you for choosing a **SAMOA** product.
 As well as the product purchased, you will receive a range of support services
 enabling you to achieve the results desired, quickly and professionally.

WARNINGS

The table below provides the meaning of the symbols used in this manual in relation to using, earthing, operating, maintaining, and repairing of this equipment.

	<p>Read this operator's manual carefully before using the equipment. An improper use of this machine can cause injuries to people or things. Do not use this machine when under the influence of drugs or alcohol. Never modify the equipment under any circumstances. Use products and solvents that are compatible with the various parts of the equipment, and read the manufacturer's warnings carefully. See the Technical Details for the equipment given in the Manual. Check the equipment for worn parts once a day. If any worn parts are found, replace them using ONLY original spare parts. Keep children and animals away from work area. Comply with all safety standards.</p>
	<p>It indicates an accident risk or serious damage to equipment if this warning is not followed.</p>
	<p>It indicates a fire or explosion risk if this warning is not followed. Eliminate all ignition sources such as pilot lights, cigarettes, portable electric lamps and plastic drop cloths. Keep work area free of debris. ONLY use this equipment in a well ventilated area. EARTH ALL THE EQUIPMENT LOCATED IN THE WORK AREA. Do not form connections or switch light switches on or off if the air contains inflammable fumes. If electrical shocks or discharges are encountered the operation being carried out using the equipment must be stopped immediately. Keep a fire extinguisher at hand in the immediate vicinity of the work area.</p>
	<p>It indicates wound and finger squashing risk due to movable parts in the equipment. Keep far from moving parts. Do not use the equipment without the proper protection. Before any inspection or maintenance of the equipment, carry out the decompression procedure explained in this manual, and prevent any risk of the equipment starting unexpectedly.</p>
 	<p>Report any risk of chemical reaction or explosion if this warning has not been given. There is a risk of injury or serious lesion related to contact with the jet from the spray gun. If this should occur, IMMEDIATELY contact a doctor, indicating the type of product injected. Do not spray before the guard has been placed over the nozzle and the trigger on the spray gun. Do not put your fingers in the spray gun nozzle. Once work has been completed, before carrying out any maintenance, complete the decompression procedure explained in this manual.</p>
	<p>It indicates important recommendations about disposal and recycling process of products in accordance with the environmental regulations.</p>
	<p>Report any danger of electric shock if the warning and presence of live electrical parts has not been indicated. Store in a dry place and do not expose to the rain. Check that the cables are in good condition. Switch off the equipment and discharge any electricity before cleaning or maintaining the equipment.</p>
	<p>Mark any clamps attached to earth cables. Use ONLY 3-wire extension cords and grounded electrical outlets. Before starting work make sure that the electrical system is earthed and that it complies with safety standards.</p>
   	<p>It is obligatory to wear suitable clothing as gloves, goggles and face shield. Wear clothing that complies with the safety standards in force in the country in which the equipment is used. Do not wear bracelets, earrings, rings, chains, or anything else that may hinder the operator's work. Do not wear clothing with wide sleeves, scarves, ties, or any other piece of clothing that could get tangled up in moving parts of the equipment during the work, inspection, or maintenance cycles.</p>

A WORKING PRINCIPLE

The **EVEREST TH LINER** is a self-propelled device which was conceived and designed for performing road markings along particularly difficult tracts of uneven road where marking would otherwise be difficult to complete.

The internal combustion engine, mounted upon the undercarriage, powers the alternative piston pump and the alternator which is utilised for charging the battery unit. The two-wheel frontal-traction is powered by an electric motor which allows for easy operator movement, even on medium-grade inclines. The control zone allows for the possibility of:

- Activating the two dispensing spray guns;
- Enabling or disabling the frontal steering wheel;
- Increasing the motor's Rpm's;
- Enabling / disabling front-wheel traction;
- Gradually increasing the advancement speed of the self-propelled undercarriage;
- Opening / closing flow to the 2nd spray gun;
- Selecting solid or broken-line painting functionality.

This type of device is capable of marking two side-by-side lines of the same colour simultaneously.

The lines may be solid, broken or mixed.

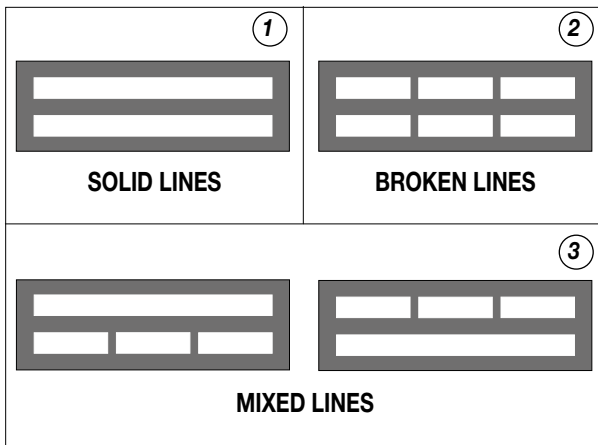

EVEREST TH LINER is perfect for large-scale lining and maintenance works.



EVEREST TH LINER allows for the marking and maintaining of all types lines on highways, freeways, pedestrian crossings, parking lots and squares, as well as every horizontal marking required by the highway code.

Airless marking has numerous proven benefits with respect to line-markers with pressurised tanks, which have been rendered obsolete by airless-technology line markers.

Airless line-marking guarantees:

- Decreased Environmental Impact;
- Decreased drying time.

The paint dries quickly and the line is defined in a uniform manner with a single coat. The airless function requires the use of filtered paint which is specifically designed for airless application. This means that the paint is homogeneous, of a smooth and uniform consistency and will not form crusts, nor will it become gelatinous or thick. With this airless line-marker, the paint adheres firmly to all types of pavement, with optimal visibility, and is resistance to wear caused both by traffic as well as atmospheric agents.

The refractive effect is obtained by the release of refractive spheres from an appropriate tank.

These spheres automatically "fall" onto the painted line and, for this reason, pre-mixed or beaded paints do not have to be used. The device's continued proper function is guaranteed through the exclusive use of suitable and quality paints. A high degree of workplace safety and cleanliness is achieved thanks to the help of the pressurised tanks.

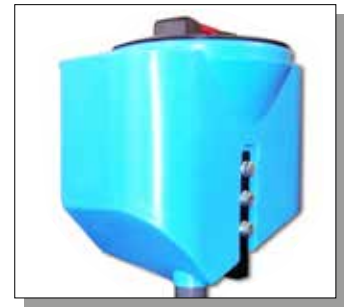

In these models, the paint canister can be loaded directly upon the undercarriage or else poured into the non-stick, 50 L tank. In every case, cleaning, maintenance and colour change operations are facilitated.



The line-marker is equipped with a 360° pivoting frontal wheel which even increases the agility of the larger models. High yield, high efficiency, high versatility.



This line-marker utilises non-premixed paints. This allows it to achieve about 30% more yield with respect to standard line-markers. Every model is also an airless spray gun which can be used in the construction/decoration sector together with washable products, enamels, breathable paints and flooring resins. A vast assortment of accessories is available to satisfy every customer demand.

B TECHNICAL DATA

EVEREST LINER	
Motor power	14 - HP
Max. Delivery	9 - l/m
Max. pressure	230 bar
Airless spray-guns	N°2 AT 250
Sizes of the furnished nozzles	2 x 13-40 - 2 x 17-40 - 2 x 21-40 - 1 x 19-40
50 L tank	series
Colours	1
Automatic line-marking	series
Applications	Excellent road-marking and maintenance
Multi-use sprayer	series
Weight	260 kg
Length	(A) 2000 mm
Height	(B) 1100 mm
Width	(C) 800 mm
Vibrations	$L_{eq(8h)}=1.5 \text{ m/s}^2$

Standard equipment	Accessories	Models
N°1 High pressure tube 3/16" mt.10 N°1 Piston surge compensator N°1 Recirculation tube N°1 1 50 L gravity tank + closure valve and extractible filter N°1 Manual airless spray-gun AT250 N°2 Automatic airless spray-gun LA95 N°3 Super fast clean bases N°2 Super fast clean nozzles 13-40 N°2 Super fast clean nozzles 17-40 N°2 Super fast clean nozzles 21-40 N°1 Super fast clean nozzles 19-40 N°1 Pole with flashing light N°1 Lining setting and speed control board N°1 Automatic glass bead dispenser N°1 Laser pointer kit N°1 Working spotlight N°1 Operator platform N°1 Tool pack	Rif. 4720 Operator holder seat kit	Rif. 4000 Everest TH + Auto- traction + Automatic line-marking sequencer

APPLICATION FIELDS

- External or underground parking lots (schools, hotels, airports, supermarkets, train stations, subway stations, ports);
- External public areas;
- Industrial and exhibition building zones;
- Freeway service areas and service stations;
- Pedestrian median lines, intersections, bicycle tracks, reserved lanes;
- Internal and external logistic area markings;
- Playing fields.

LA95 airless spray gun
For lines from 3 to 30 cm wide, mounted on an adjustable block: modify the spray pattern by altering the height of the gun or nozzle.



Head Liner Control
Easy and functional with: Automatic marking sequencer, electronic speed control and built-in safety devices.

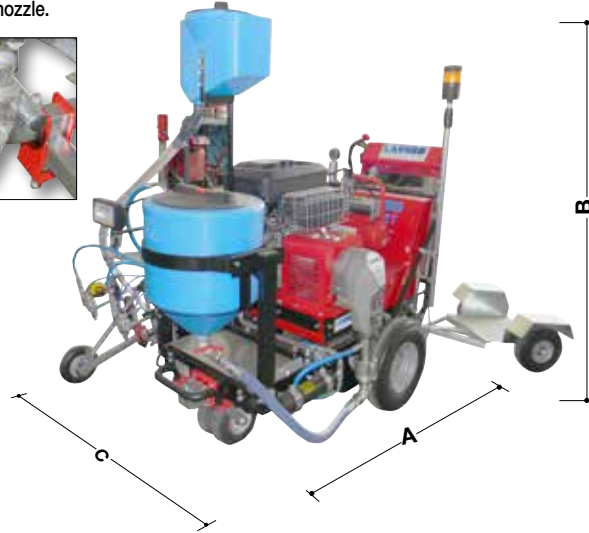

400 mm Ø pneumatic wheels guarantee stability and ease of movement as well as reduce the unevenness of the road's surface.

SFC SPRAY TIPS/NOZZLES TABLE - TSC

Ø nozzle (inch)	Spray angle (°)	Line Width		Flow rate (gpm)	Flow rate (lpm)
		inch	mm		
.013	13 - 20	2 - 4	51 - 102	.18	.69
.015	15 - 20	2 - 4	51 - 102	.24	.91
	15 - 30	4 - 6	102 - 152		
.017	17 - 20	2 - 4	51 - 102	.31	1.17
	17 - 30	4 - 6	102 - 152		
	17 - 40	4 - 8	102 - 204		
.019	19 - 20	2 - 4	51 - 102	.38	1.47
	19 - 30	4 - 6	102 - 152		
	19 - 40	4 - 8	102 - 204		
.021	21 - 30	4 - 6	102 - 152	.47	1.79
	21 - 40	4 - 8	102 - 204		
	21 - 60	8 - 12	204 - 305		
.023	23 - 30	4 - 6	102 - 152	.57	2.15
	23 - 40	4 - 8	102 - 204		
	23 - 60	8 - 12	204 - 305		
.025	25 - 30	4 - 6	102 - 152	.67	2.54
	25 - 40	4 - 8	102 - 204		
	25 - 60	8 - 12	204 - 305		
.027	27 - 30	4 - 6	102 - 152	.77	2.96
	27 - 40	4 - 8	102 - 204		
	27 - 60	8 - 12	204 - 305		

Ø nozzle (inch)	Spray angle (°)	Line Width		Flow rate (gpm)	Flow rate (lpm)
		inch	mm		
.029	29 - 30	4 - 6	102 - 152	.90	3.42
	29 - 40	4 - 8	102 - 204		
	29 - 60	8 - 12	204 - 305		
.031	31 - 30	4 - 6	102 - 152	1.03	3.90
	31 - 40	4 - 8	102 - 204		
	31 - 60	8 - 12	204 - 305		
.033	33 - 30	4 - 6	102 - 152	1.17	4.42
.035	35 - 30	4 - 6	102 - 152	1.31	4.98
	35 - 40	4 - 8	102 - 204		
	35 - 60	8 - 12	204 - 305		
.039	39 - 30	4 - 6	102 - 152	1.63	6.18
	39 - 40	4 - 8	102 - 204		
	39 - 60	8 - 12	204 - 305		
.043	43 - 30	4 - 6	102 - 152	1.98	7.51
	43 - 40	4 - 8	102 - 204		
	43 - 60	8 - 12	204 - 305		

C DESCRIPTION OF THE EQUIPMENT

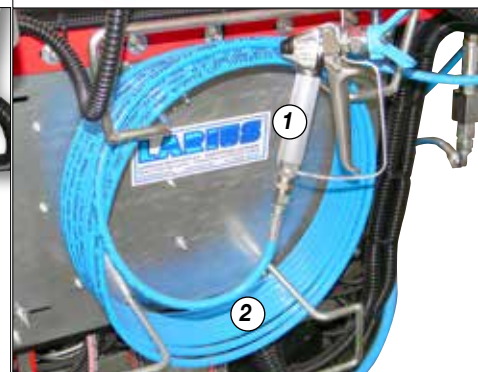
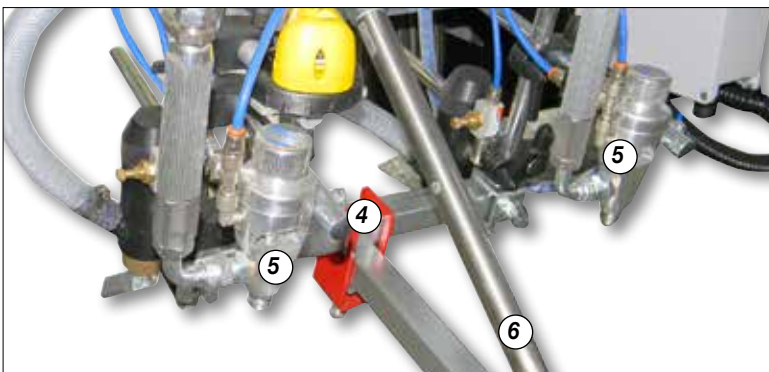
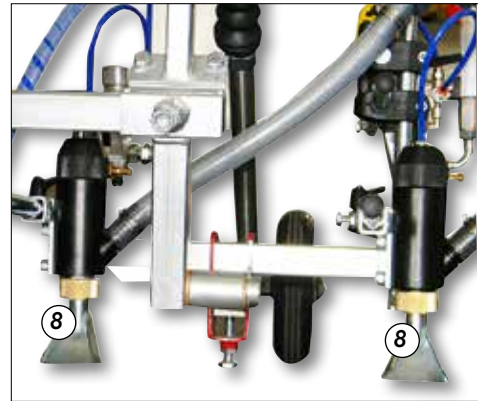

POS.	Description
1	Airless manual gun AT 250
2	High pressure hose
3	Internal combustion engine
4	Gun holding arm
5	LA95 airless spray-guns

POS.	Description
6	Stablizer lifting cylinder
7	Additional cord pull-start ignition
8	Reflecting pears distributors
9	Super fast clean nozzle

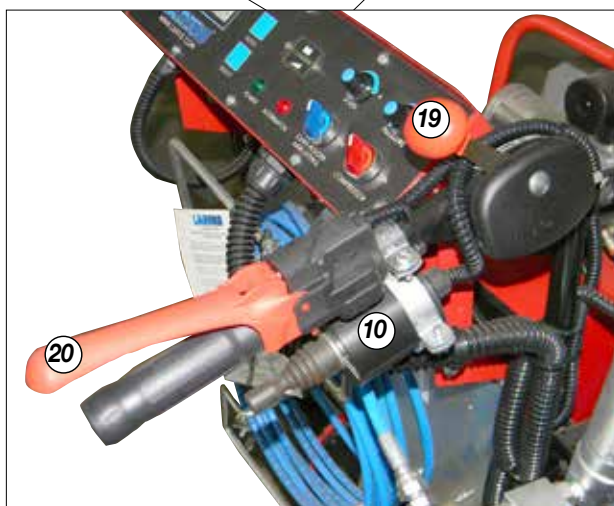
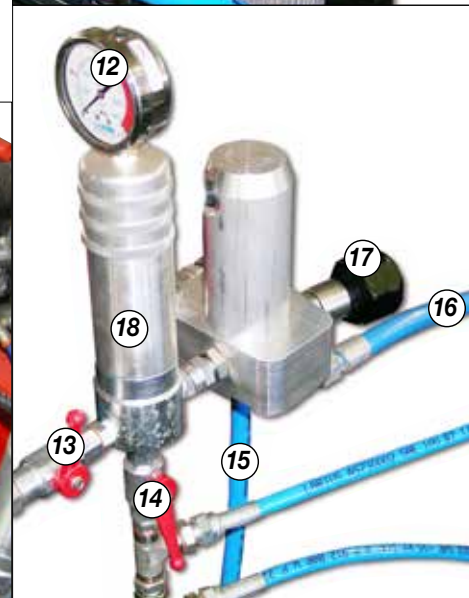
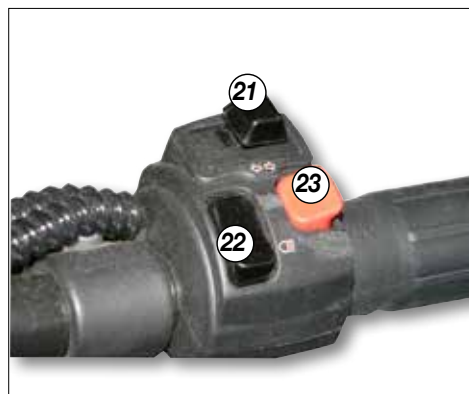
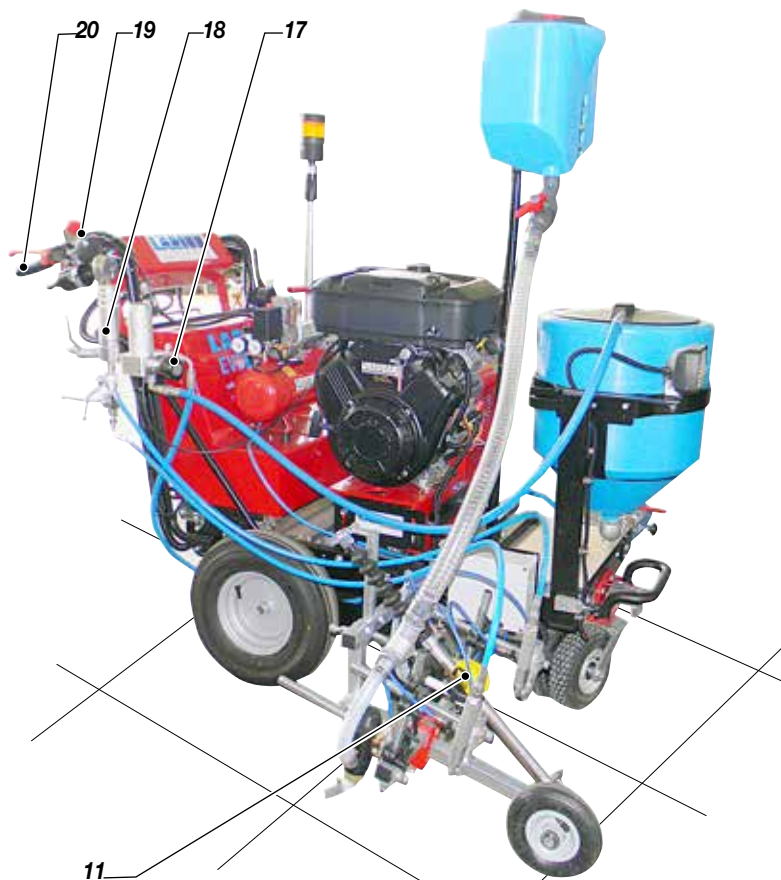

POS.	Description
10	Automatic lever for selecting solid or broken line painting functionality
11	Laser pointer
12	Manometer
13	Manual airless spray intake valve
14	Spray-guns intake valve
15	Product supply tube
16	Recirculation tube

POS.	Description
17	Recirculation - safety valve
18	Intake filter
19	Internal combustion engine accelerator
20	Machine driving lever
21	Forward and backward selector
22	Light switch
23	Manual spraying control switch



POS.	Description
24	Control Head Liner
25	Flow compensator
26	Pneumatic system supply compressor
27	lt. 50 tank

POS.	Description
28	Refractive sphere tank
29	Electric motor for forward/reverse movement
30	Direction locking / releasing lever
31	Clutch releasing lever

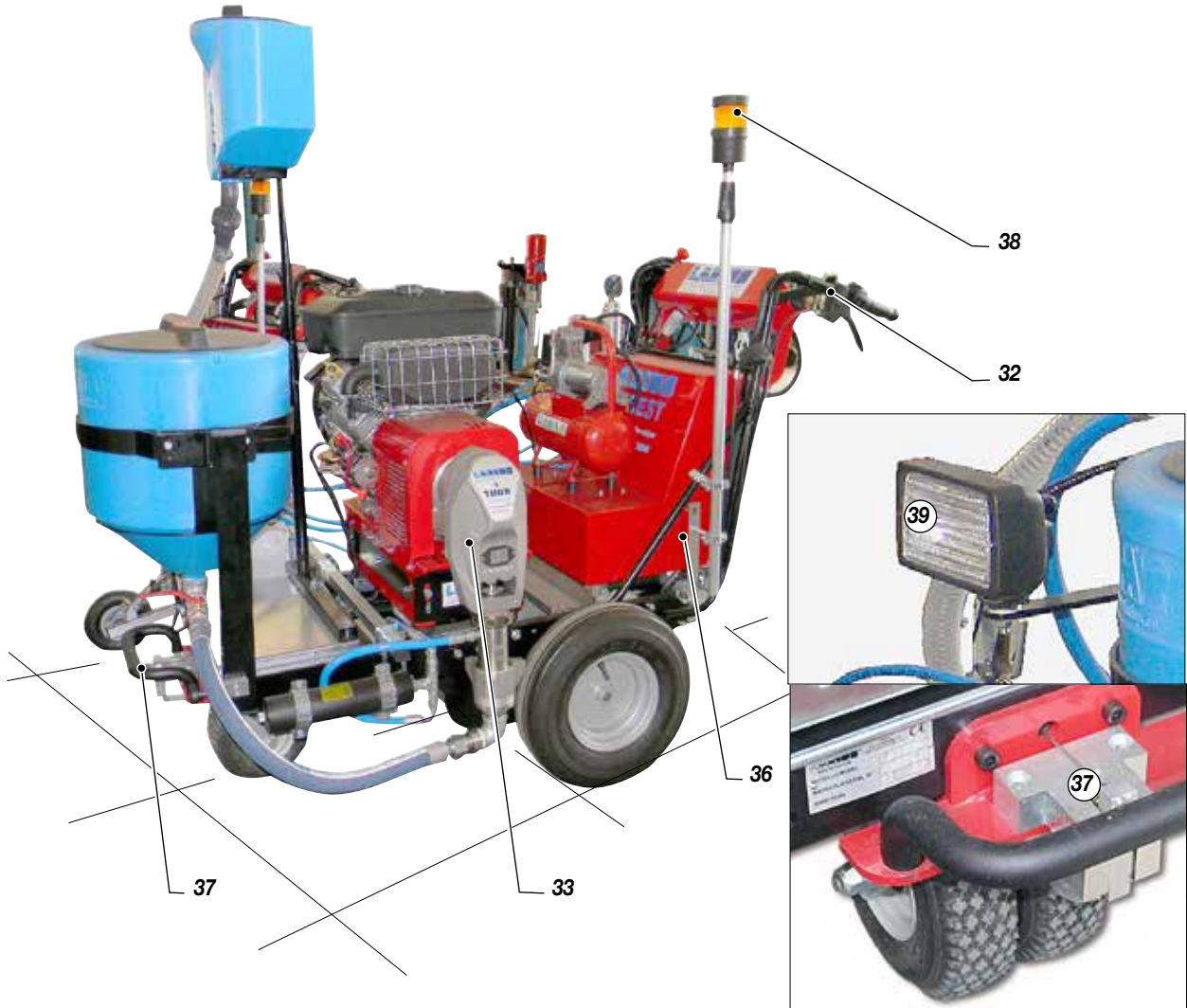

POS.	Description
32	Undercarriage structure for economic handling
33	Pumping group
34	Electric alternator for battery recharging
35	Operator footboard

POS.	Description
36	Traction batteries
37	Frontal steering unit
38	Flashing light
39	Frontal light

D TRANSPORT AND UNPACKING

- The packed parts should be handled as indicated in the symbols and markings on the outside of the packing.
- Before installing the equipment, ensure that the area to be used is large enough for such purposes, is properly lit and has a clean, smooth floor surface.



	<p>The user is responsible for the operations of unloading and handling and should use the maximum care so as not to damage the individual parts or injure anyone.</p> <p>To perform the unloading operation, use only qualified and trained personnel (<i>truck and crane operators, etc.</i>) and also suitable hoisting equipment for the weight of the installation or its parts. Follow carefully all the safety rules. The personnel must be equipped with the necessary safety clothing.</p>
---	---

- The manufacturer will not be responsible for the unloading operations and transport to the workplace of the machine.
- Check the packing is undamaged on receipt of the equipment. Unpack the machine and verify if there has been any damage due to transportation. In case of damage, call immediately the manufacturer and the Shipping Agent. All the notices about possible damage or anomalies must arrive timely within 8 days at least from the date of receipt of the plant through Registered Letter to the Shipping Agent and to the manufacturer.

	<p>The disposal of packaging materials is a customer's competence and must be performed in accordance with the regulations in force in the country where the plant is installed and used. It is nevertheless sound practice to recycle packaging materials in an environment-friendly manner as much as possible.</p>
---	---

E SAFETY RULES

- THE EMPLOYER SHALL TRAIN ITS EMPLOYEES ABOUT ALL THOSE RISKS STEMMING FROM ACCIDENTS, ABOUT THE USE OF SAFETY DEVICES FOR THEIR OWN SAFETY AND ABOUT THE GENERAL RULES FOR ACCIDENT PREVENTION IN COMPLIANCE WITH INTERNATIONAL REGULATIONS AND WITH THE LAWS OF THE COUNTRY WHERE THE PLANT IS USED.
- THE BEHAVIOUR OF THE EMPLOYEES SHALL STRICTLY COMPLY WITH THE ACCIDENT PREVENTION AND ALSO ENVIRONMENTAL REGULATIONS IN FORCE IN THE COUNTRY WHERE THE PLANT IS INSTALLED AND USED.
- KEEP YOUR WORK PLACE CLEAN AND TIDY. DISORDER

	<p>Read carefully and entirely the following instructions before using the product. Please save these instructions in a safe place.</p>
	<p>The unauthorised tampering/replacement of one or more parts composing the machine, the use of accessories, tools, expendable materials other than those recommended by the manufacturer can be a danger of accident.</p>
	<p>The manufacturer will be relieved from tort and criminal liability.</p>

WHERE YOU ARE WORKING CREATES A POTENTIAL RISK OF ACCIDENTS.

- ALWAYS KEEP PROPER BALANCE AVOIDING UNUSUAL STANCE.
- BEFORE USING THE TOOL, ENSURE THERE ARE NOT DAMAGED PARTS AND THE MACHINE CAN WORK PROPERLY.
- ALWAYS FOLLOW THE INSTRUCTIONS ABOUT SAFETY AND THE REGULATIONS IN FORCE.
- KEEP THOSE WHO ARE NOT RESPONSIBLE FOR THE EQUIPMENT OUT OF THE WORK AREA.
- NEVER EXCEED THE MAXIMUM WORKING PRESSURE INDICATED.
- NEVER POINT THE SPRAY GUN AT YOURSELVES OR AT OTHER PEOPLE. THE CONTACT WITH THE CASTING CAN CAUSE SERIOUS INJURIES.
- IN CASE OF INJURIES CAUSED BY THE GUN CASTING, SEEK IMMEDIATE MEDICAL ADVICE SPECIFYING THE TYPE OF THE PRODUCT INJECTED. NEVER UNDERVALUE A WOUND CAUSED BY THE INJECTION OF A FLUID.
- ALWAYS DISCONNECT THE SUPPLY AND RELEASE THE PRESSURE IN THE CIRCUIT BEFORE PERFORMING ANY CHECK OR PART REPLACEMENT OF THE EQUIPMENT.
- NEVER MODIFY ANY PART IN THE EQUIPMENT. CHECK REGULARLY THE COMPONENTS OF THE SYSTEM. REPLACE THE PARTS DAMAGED OR WORN.
- TIGHTEN AND CHECK ALL THE FITTINGS FOR CONNECTION BETWEEN PUMP, FLEXIBLE HOSE AND SPRAY GUN BEFORE USING THE EQUIPMENT.
- ALWAYS USE THE FLEXIBLE HOSE SUPPLIED WITH STANDARD KIT. THE USE OF ANY ACCESSORIES OR TOOLING OTHER THAN THOSE RECOMMENDED IN THIS MANUAL, MAY CAUSE DAMAGE OR INJURE THE OPERATOR.
- THE FLUID CONTAINED IN THE FLEXIBLE HOSE CAN BE VERY DANGEROUS. HANDLE THE FLEXIBLE HOSE CAREFULLY. DO NOT PULL THE FLEXIBLE HOSE TO MOVE THE EQUIPMENT. NEVER USE A DAMAGED OR A REPAIRED FLEXIBLE HOSE.

 The high speed of travel of the product in the hose can create static electricity through discharges and sparks. The pump is earthed through the earth with sliding chain.

- NEVER SPRAY OVER FLAMMABLE PRODUCTS OR SOLVENTS IN CLOSED PLACES.
- NEVER USE THE TOOLING IN PRESENCE OF POTENTIALLY EXPLOSIVE GAS.

 Always check the product is compatible with the materials composing the equipment (*pump, spray gun, flexible hose and accessories*) with which it can come into contact. Never use paints or solvents containing halogen hydrocarbons (*as the methylene chloride*).
If these products come into contact with aluminium parts can provoke dangerous chemical reactions with risk of corrosion and explosion.

 IF THE PRODUCT TO BE USED IS TOXIC, AVOID INHALATION AND CONTACT BY USING PROTECTION GLOVES, GOGGLES AND PROPER FACE SHIELDS.

 TAKE PROPER SAFETY MEASURES FOR THE PROTECTION OF HEARING IN CASE OF WORK NEAR THE PLANT.

Engine safety precautions:

- Read the engine operator's manual annex.



 Never attempt to tamper with the calibre of instruments.

CONDITIONS OF GUARANTEE

 The conditions of guarantee do not apply in the following situations:

- improper washing and cleaning of components causing malfunction, wear or damage to the equipment or any of its parts;
- improper use of the equipment;
- use that does not conform with applicable national legislation;
- incorrect or faulty installation;
- modifications, interventions and maintenance that have not been authorised by the manufacturer;
- use of non-original spare parts or parts that do not correspond to the specific model;
- total or partial non-compliance with the instructions provided.

F SETTING-UP

CONNECTION OF THE GUNS

- Connect the high pressure hoses (F1) to the pump and guns (F2), taking care to fasten the connections tightly (*we recommend using two wrenches*).
- It is recommended to use the hose provided with the standard kit.
NEVER use a damaged or a repaired flexible hose.

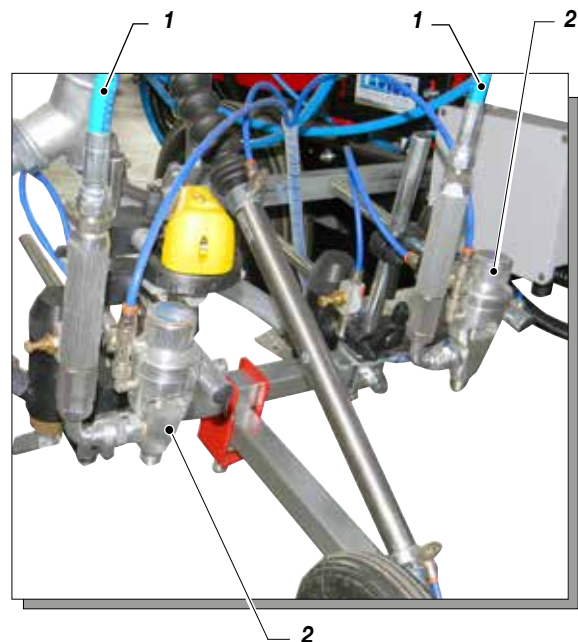

CONNECTION OF THE MANUAL GUN

- Connect the high pressure flexible hose (4) to the fitting (5) and the gun (6) tightening the fittings strongly (*the use of two wrenches is suggested*).

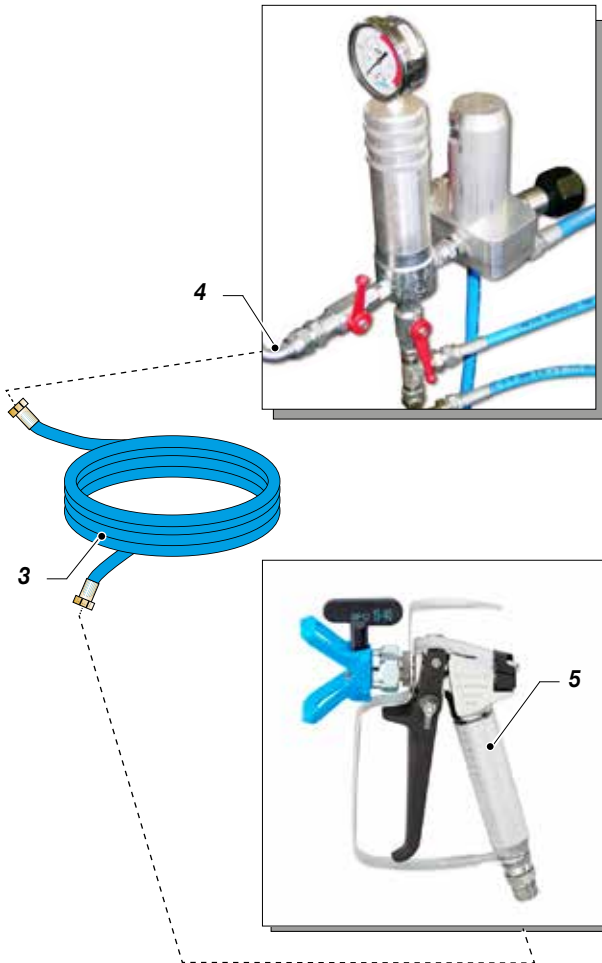

- Pull lever (6) for first start-up (only when cold). Open the fuel tap (7).
- Bring the accelerator lever (8) to about 1/2 of its run.
- Rotate the key (9) to enable the electric ignition.

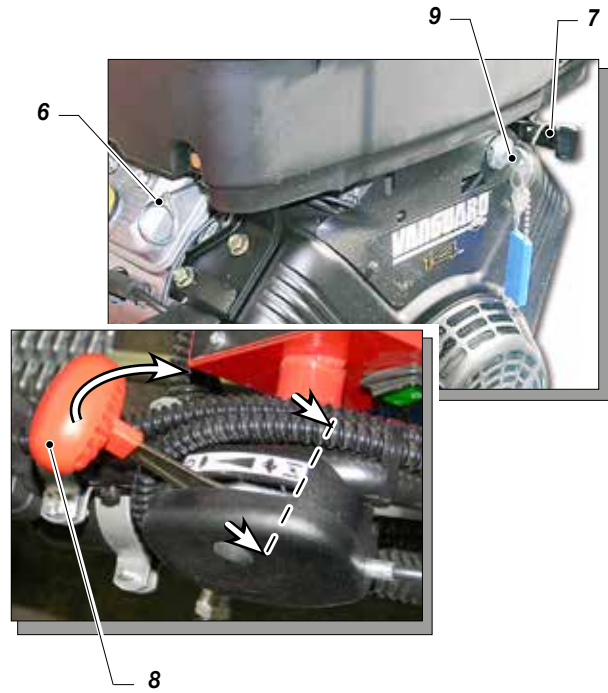

- Turn the equipment's switch (10) to ON (I) in order to enable the control Head Liner panel.

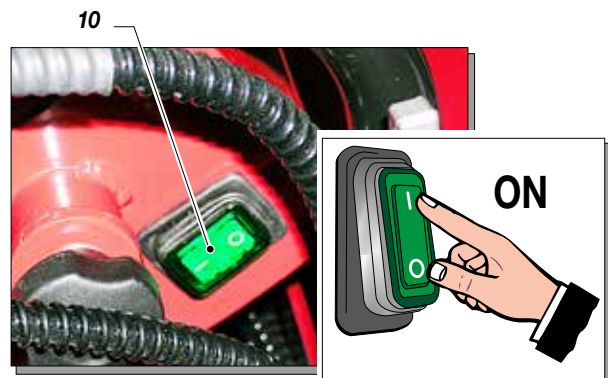

WASHING OF THE NEW EQUIPMENT

- The equipment has already been adjusted at our factory with light mineral oil left inside the pumping group as protection. Therefore, wash with diluent before sucking the product.
- Fill the product tank with wash fluid.
- Ensure the guns (2-5) is without nozzle.



- Turn pressure regulating knob (11) clockwise a little so that the machine idles.

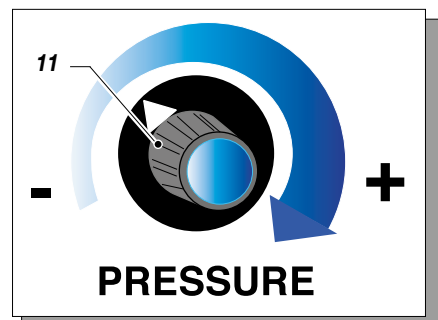

- Open the re-circulation valve (12).
- Visually check that the wash fluid starts to re-circulate within the tank (13).
- Close the re-circulation valve (12).
- Open the tap (14) of the manual gun.

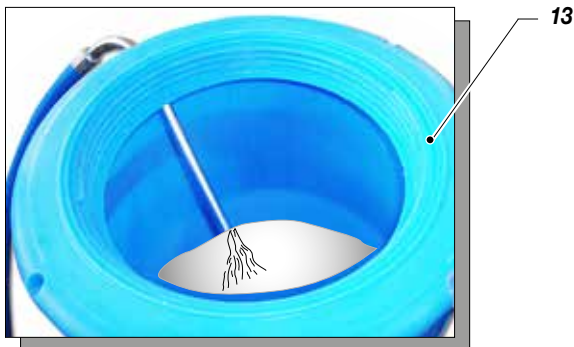
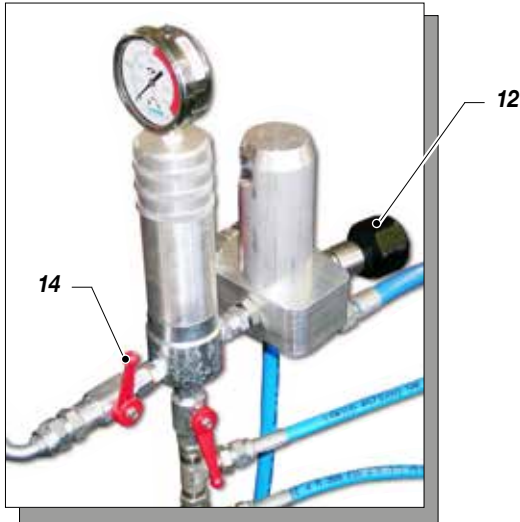

- Point the manual gun (15) at a container (16) and keep pressed the trigger lever (so as to drain the oil inside) till a clean solvent comes out. Now, release the lever.

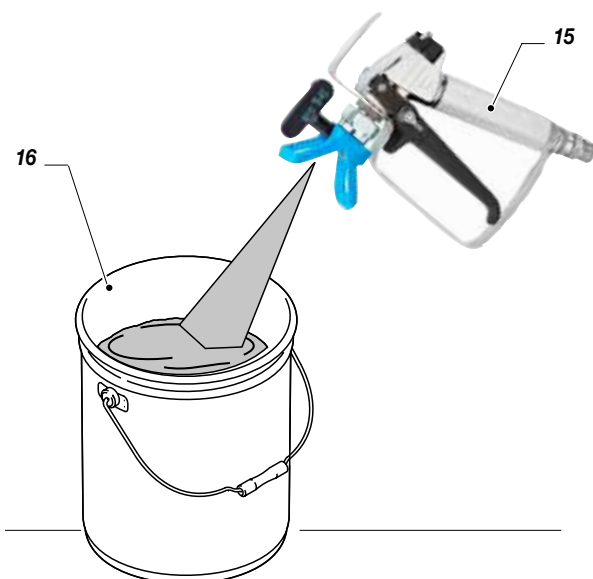

- Enable the engine ignition control with the key (14).
- Open the tap (17) of the automatic guns.

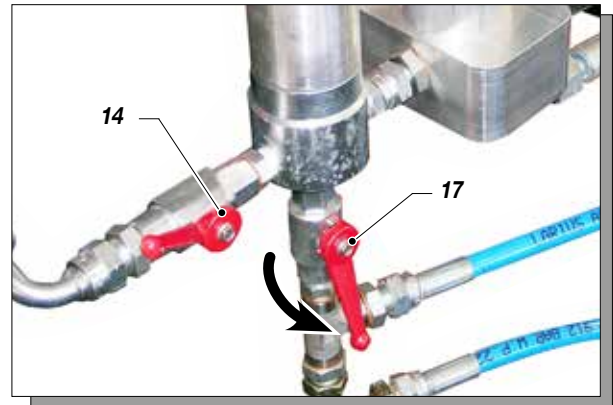

- Perform the same operation for the automatic spray guns as well (see *Head Liner control bridge instructions*).
- Eliminate any solvent which remains within the tubes by activating the manual and automatic guns.
- As soon as the pump begins to run dry, turn the handle (F11) to minimum to stop the system.

⚠ Absolutely avoid spraying solvents in closed environments. It is also recommended to keep the spray gun away from the pump in order to prevent vapours from coming into contact with the electrical motor.

- Stop the combustion engine.
- At this point the machine is ready. If water-based paints are to be used, after the wash with solvent wash the tank again with soap and water, then rinse with clean water (repeating the previously described procedures).
- Insert the manual gun trigger lock and assemble the nozzle.
- Insert the automatic guns trigger lock and assemble the nozzles.

PREPARATION OF THE PAINT

- Make sure the product is suitable to be used with a spray gun.
- Mix and filter the product before using it. For filtration use **CLOSE-MESH** (ref. 214) and **LARGE-MESH** (ref. 215) LARIUS METEX braids.

⚠ Make sure the product to be used is compatible with the materials employed for manufacturing the equipment (*stainless steel and aluminium*). Because of that, please contact the supplier of the product.

- Fill the tank (F13) with the paint.

Never use products containing halogen hydrocarbons (as *methylene chloride*). If these products come into contact with aluminium parts of the equipment, can provoke dangerous chemical reactions with risk of explosion.

G WORKING

SETUP PROCEDURE

- Use the tooling after performing all the **SETTING UP** operations above described.
- Make sure that all the levers are in the “DISENGAGED” position.
- Check that the automatic lever (1) is in its “0” position..

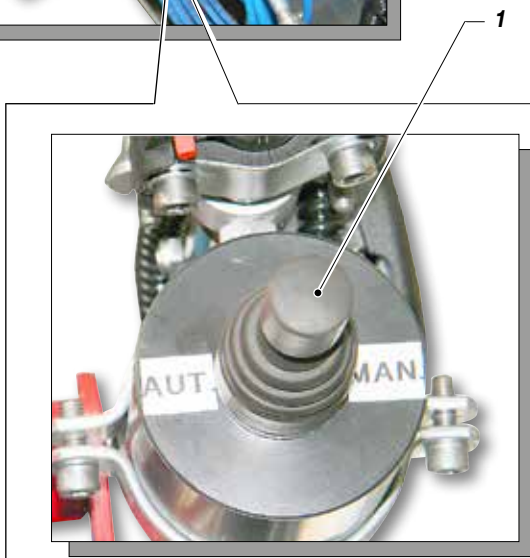

- Check that there is enough unleaded petrol. Turn fuel (2) knob to “ON”.



- Enable the engine ignition control with the key (3)



- Open the re-circulation valve (4).
- Turn pressure regulating knob (5) clockwise a little so that the machine idles.
- Visually check that the product starts to re-circulate within the tank.
- Close the re-circulation valve (4).
- Open the tap (6) of the automatic guns.
- Open the tap (7) (if necessary only for painting with the manual gun).
- Turn the pressure adjustment handle (G5) to the necessary operating value (120 ÷ 190 bar).

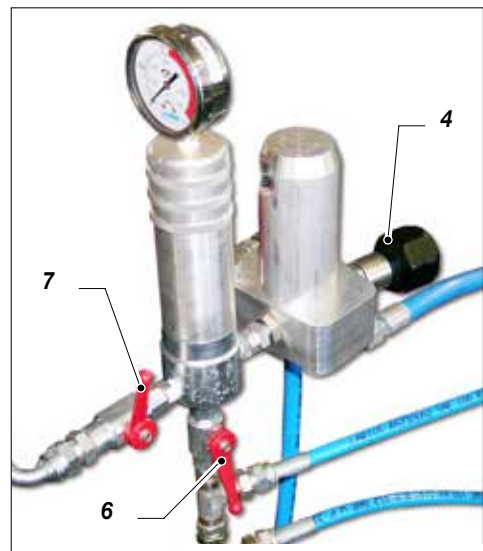

- Activate the compressor (8) (adjust the compressor's pressure to 6 bar).

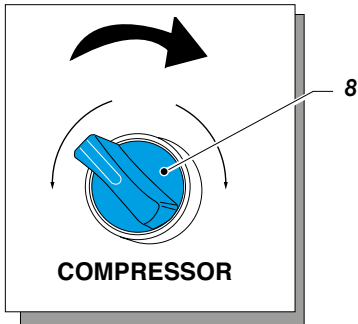

- Release the clutch using the lever (9), in order to be able to move the machine more easily and accurately.

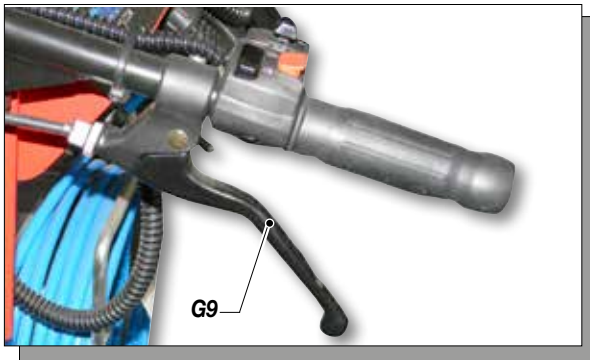

ADJUSTING PUMP UNIT SPEED

- Move the motor acceleration lever (10) gently to increase or decrease the speed of the pump. During the painting operation it is normally recommended to maintain the position of the accelerator lever (10) at about 3/4 of its run.

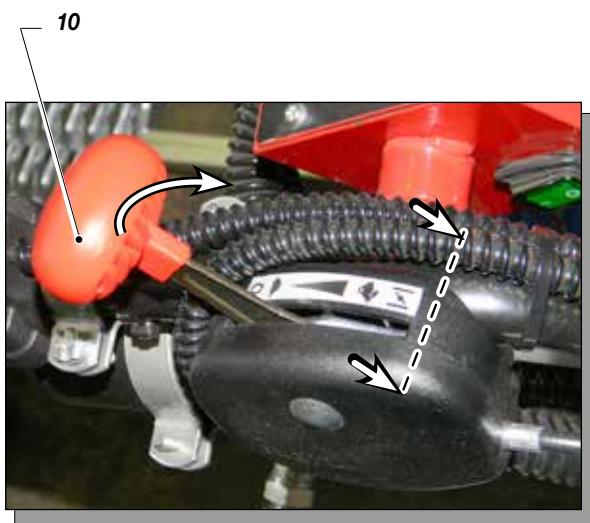

H PAINTING OPERATIONS

- In order to use the spray-guns, open the valve (1) located at the intake filter's outlet. In this manner both line-marking spray-guns will have the possibility of dispensing paint by moving the appropriate manual lever or the automatic lever.

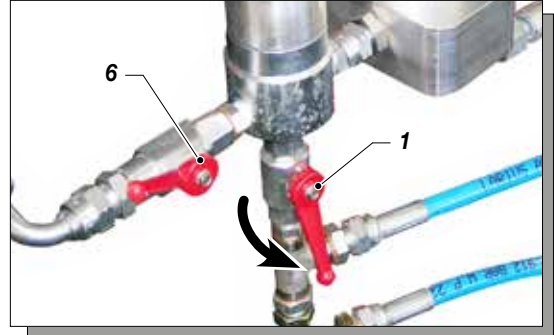

- The control lever (3) located on the right handle can be positioned to "T" (DASHED) or to "C" (CONTINUOUS) in order to set the automatic guns' operating conditions. (See the "control bridge use" section for programming).

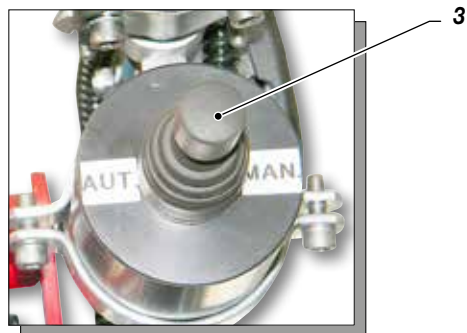

- The machine is outfitted with a third manual (4) gun with a 15-meter tube (5) to perform roadside writings with paint templates. The gun is situated under the control handles placed on the special tube winder.
- In order to use the manual spray-gun, open the valve (6) located at the intake filter's outlet

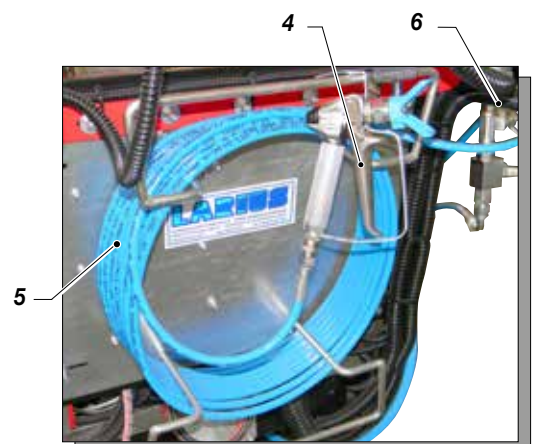

- If operation is required upon a long rectilinear section, the lever (7) must be placed in its "A" position. A spring-action mechanical stopper will automatically block the front wheel (8) in its straight position, thereby ensuring a straight trajectory for the operator.

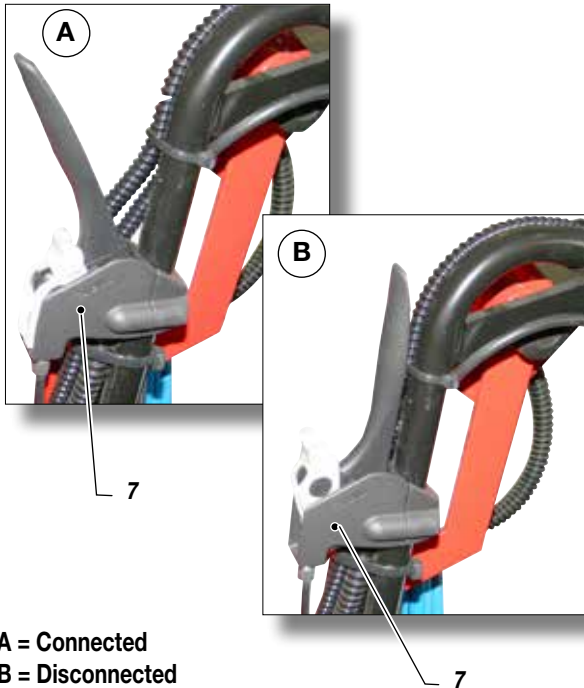

A = Connected
B = Disconnected



- Press the advancement lever (9) and begin to work based on the set cycle by activating the gun control lever "Aut" or "Man" (3).

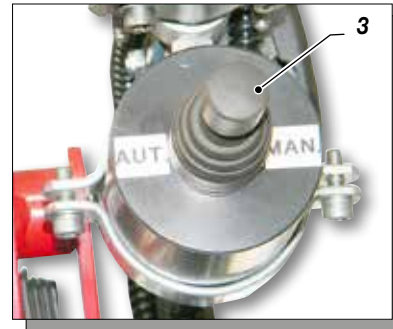
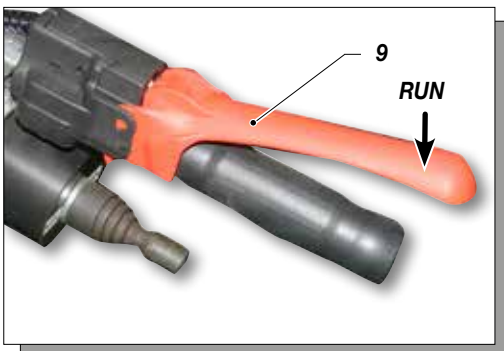

SPRAY ADJUSTMENT

- Slowly turn clockwise the pressure control knob to reach the pressure value in order to ensure a good atomization of the product.
- An irregular and marked spray on the sides indicates a low working pressure. On the contrary, a too high pressure causes a high fog ("overspray") and waste of product.
- In order to avoid excess paint pressure, do not spray if not simultaneously advancing with the machine.
- Always paint with regular parallel bands coats (*manual guns*).
- Keep a safety and constant distance between the gun and the support to be painted and also keep yourselves perpendicular to it.



NEVER point the spray gun at yourselves or at other people. The contact with the casting can cause serious injuries.



In case of injuries caused by the gun casting, seek immediate medical advice specifying the type of the product injected.



Recirculation - safety valve: when working at the maximum pressure available, releasing the gun trigger sudden increases of pressure can occur. In this case, the recirculation - safety valve opens automatically eliminating part of the product from the recirculating tube. Then it closes so as to go back to the first working conditions.



After the unit's use, follow all procedures for decompression and cleaning indicated in the attached maintenance and use manual. Upon completion of work, switch the lever into the resting position.

I APPENDIX “A”: UNIT WITH PEARLIZED REFLECTING PEARLS DISTRIBUTION ACCESSORY

DESCRIPTION OF THE EQUIPMENT

With the new distribution system of reflecting pearl, the “**EVEREST TH LINER**” unit can produce a system of more visible and therefore safer roadway indication, even in the worst weather. The pearlized distribution kit is composed of a drop tank with two openings, two rubber tubes that carry the reflecting pearls to the distributors.

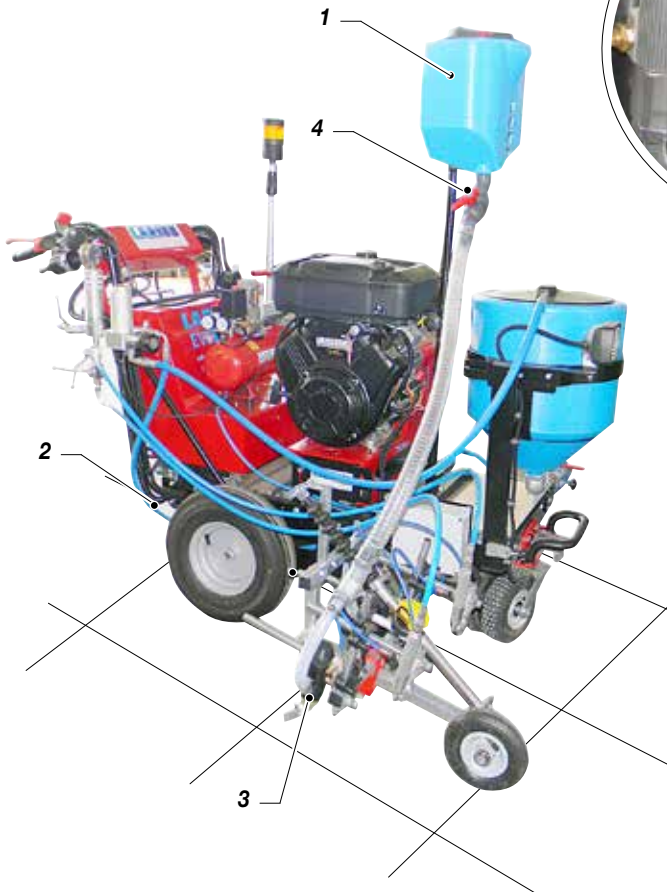

POS.	Description
1	Drop tank
2	Filling tubes
3	Reflecting pearls distributors
4	Valves for opening / closing the refracting material distributor

J REGULATIONS

ADJUSTING THE GUNS

The guns (4) are mounted on suitable sliding arms (5), (6), (7), (8). This allows the correct positioning of the guns according to working requirements.

The allowed movements are indicated by the arrows (a), (b), (c), (d).

In order to allow the shifting of the guns on the relevant arms, it is necessary to release the handles (9), (10), (11), (12) and the screws (13), (14).

Once the adjustment is completed, provide to duly tighten handles and screws.

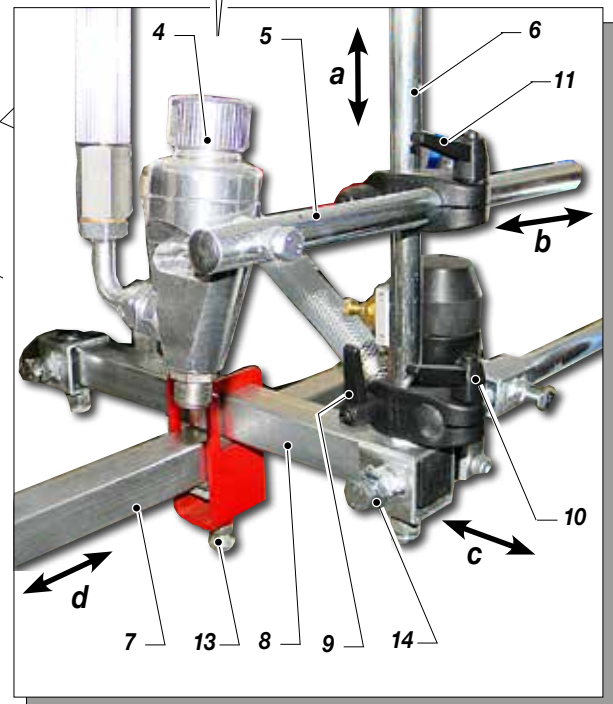
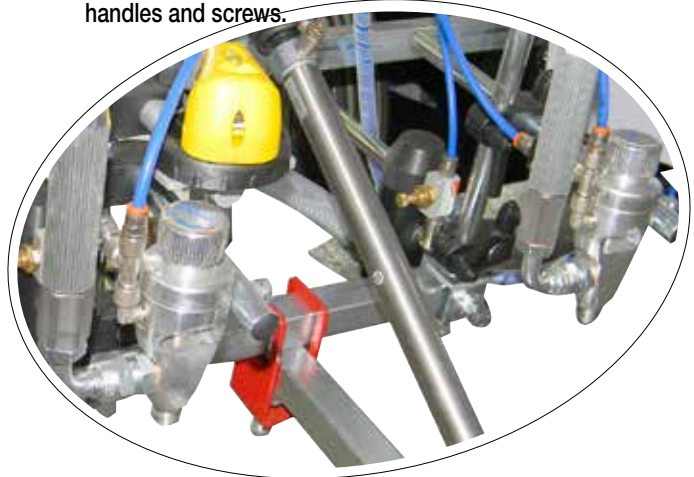

ADJUSTING THE DISTRIBUTION UNIT

To set the position of the reflecting pearls distributors (15) it is necessary to adjust the screws (16).

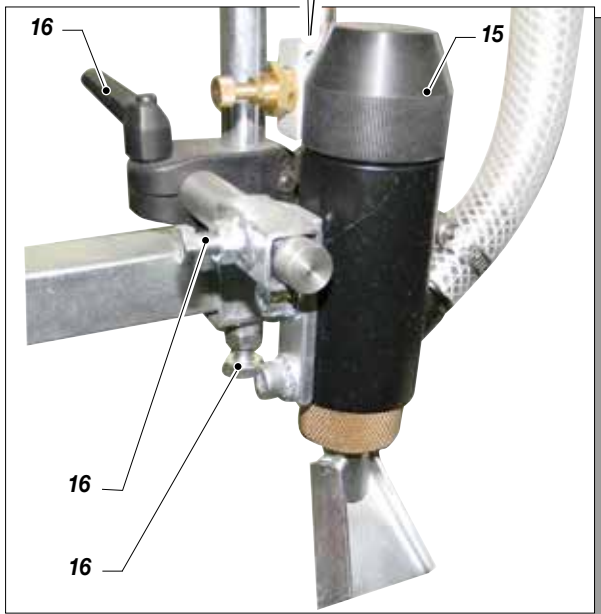
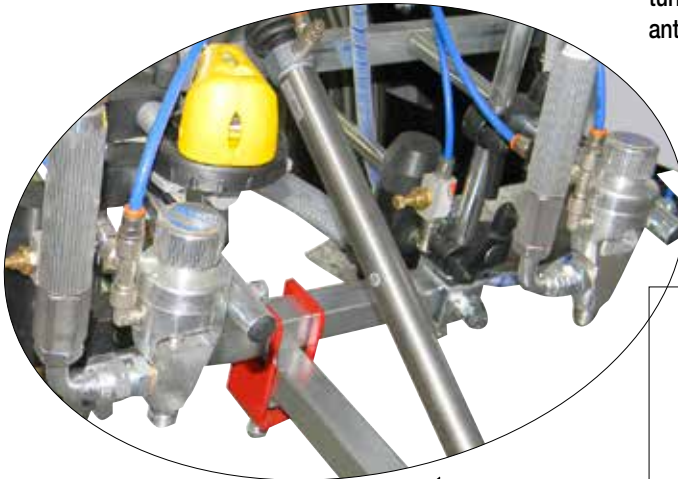

ADJUSTING THE PNEUMATIC SYSTEM PRESSURE

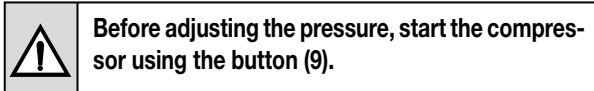

In order to regulate the pressure in the pneumatic system, turn the knob (10) clockwise (+) to increase the pressure and anticlockwise (-) to reduce it.

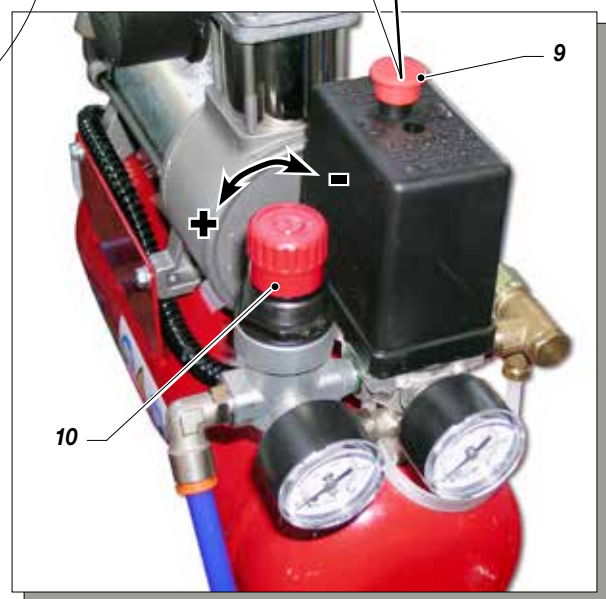
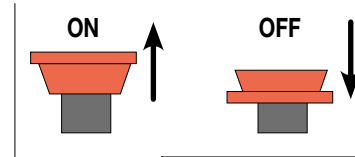

K CLEANING AT THE END OF THE WORK

- Reduce pressure to the minimum [turn counterclockwise the pressure control knob (1)].

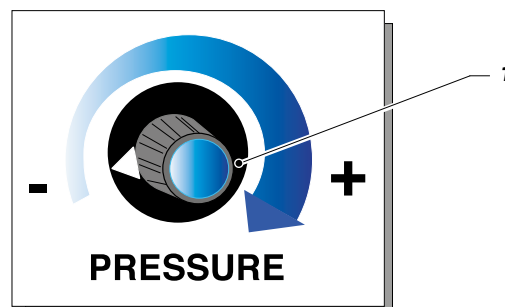

- Press the switch (2) placed on the box of the electric motor, to stop the equipment.

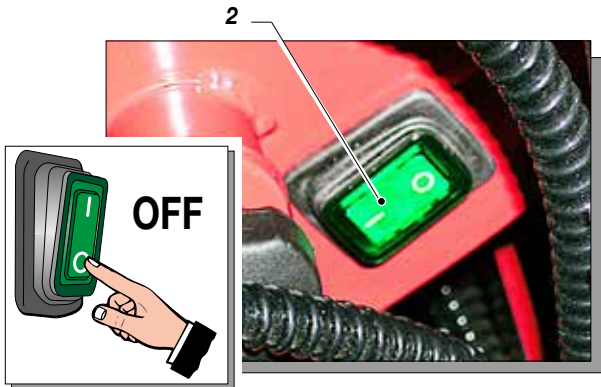

- Open the re-circulate safety valve (3) to release the pressure in the circuit.



- Eliminate any paint which remains in the tank (4) by placing the recirculation tube (5) into a container.

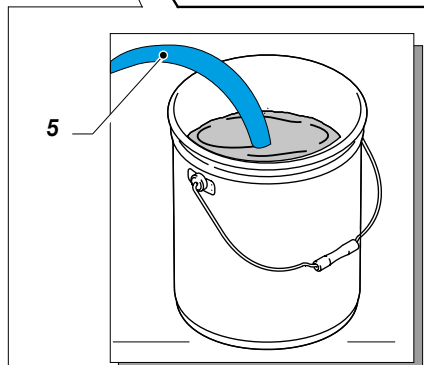
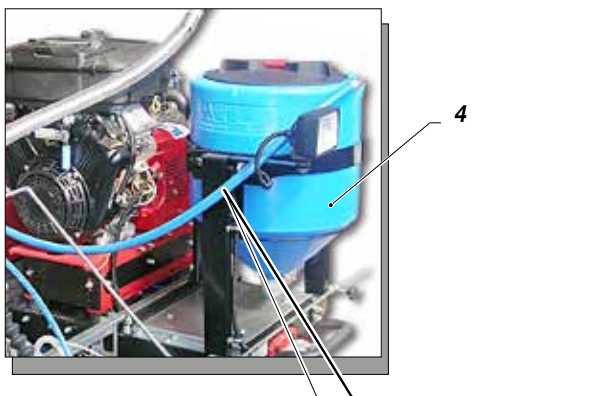

- Turn the pressure adjustment (6) handle slightly clockwise to make the machine function at minimum pressure (*pump activated*).
- Empty the tank (4).
- Turn the pressure adjustment (6) handle to minimum (*pump stopped*).
- Insert wash fluid into the tank.
- Clean the walls of the tank with a brush.
- Turn the pressure adjustment (6) handle slightly clockwise to make the machine function at minimum pressure (*pump activated*).
- Make sure the re-circulation tube is inserted into a container and wait for clean wash fluid to come out of it (*clean*).
- Turn the pressure adjustment (6) handle to minimum (*pump stopped*).
- Close the re-circulation valve (3).



- Reposition the re-circulation tube within the tank.
- Remove the nozzles from the guns and wash them separately.
- Turn the pressure adjustment (6) handle slightly clockwise to make the machine function at minimum pressure (*pump activated*).
- Point the manual gun (7) into a container (8), drain the residual paint and wait for the wash fluid to come out clean.



- Set the RH and LH guns simultaneously **MENU 1** function from the control panel.
- Move the control lever to position "C" and unload any residual paint. Wait for the cleaning liquid to come through clean.
- Remove all clearing liquid from the tank and turn the machine off.
- Turn the pressure adjustment (1) handle to minimum (*pump stopped*).

 Follow the washing procedure before using again the equipment.

L GENERAL MAINTENANCE

DAILY

- Clean the filters;
- Clean the nozzles;
- Clean all the varnish circuit with a specific product;
- Check the fuel motor (see the maintenance table).

PERIODICALLY

- Check the pumping gaskets draft (if the product draws, replace gaskets);
- Clean the mobile parts from the varnish deposits (clutch traction, spray guns, etc.);
- Check the gun cables tightening, the wheel block and the traction;
- Check that the tubes and all the fittings are correctly locked.

M CHARGING THE BATTERY

The **EVEREST TH LINER** is provided with an internal combustion engine, mounted on the trolley that drives the reciprocating piston pump and the alternator used to charge the battery pack.

 Handle the **EVEREST TH LINER** line marking equipment without the internal combustion engine running only for short distances and for short periods.

 If the equipment is handled for long distances without the internal combustion engine running, the battery pack drops below the minimum threshold level and the equipment locks up.

Start the internal combustion engine to reset and recharge the battery pack.

 If the machine is not used for long periods, it is necessary to start the internal combustion engine at least once a month.

Therefore, leave the engine running for a certain period of time to allow optimal recharging of the battery pack.

If the batteries are worn out, replace them (*see the page on Battery pack spare parts*)

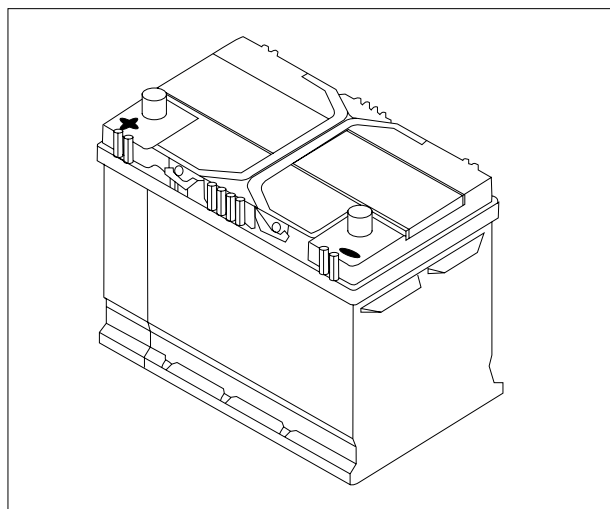

N ROUTINE MAINTENANCE



Always check that there is oil in the motor.

Motor oil cup



CHECK THE PACKING NUT

The gaskets do not need adjusting. The ring nut is only used to fit and remove gaskets and for topping up the oil.



Always disconnect the electrical supply and discharge the pressure in the pump unit (*open the discharge valve*) before carrying out any maintenance.

Wait 30 seconds before proceeding with maintenance operations to allow any residual electricity to be discharged.

- Use the lubricant (1) provided (*Ref. 16340*) to make it easier to slide the piston inside the seal pack and to substitute the air with oil.

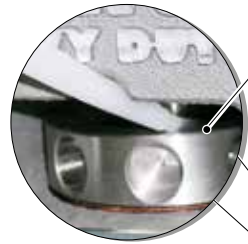

Oil ring

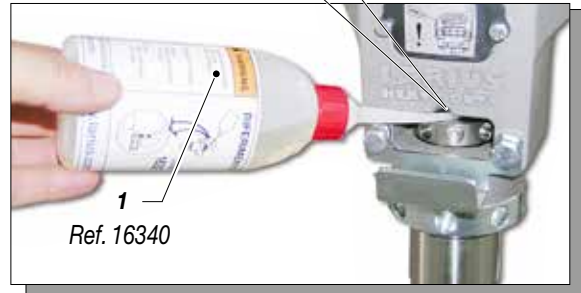

1
Ref. 16340



At the start of each working day check that the ring nut is full of hydraulic oil (*Ref. 16340*). This oil makes it easier for the piston to slide and prevents any material that escapes via the seal gasket drying when the equipment is stopped.

- The ring nut (2) must be tightened all the way. Every 100 working hours, with the pressure at 0 bar, check that it is tightened all the way.
- The pin (3) supplied (*Ref. 20144*) is used to tighten and open the pump unit (4) locking ring nut, which must always be tight to act as a locknut.

2

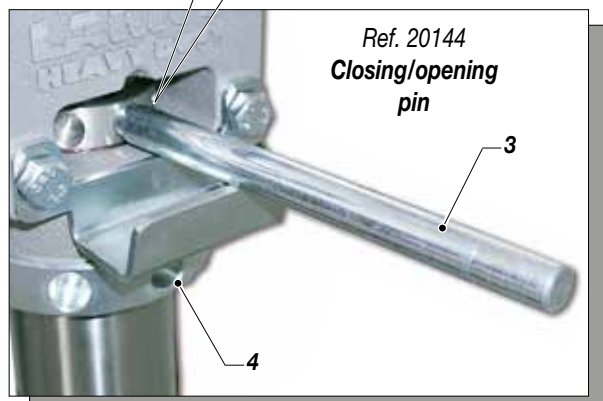

Ref. 20144
Closing/opening
pin

3

4

PRESSURE SWITCH SEAL CHECK

Check that no material is escaping from the safety hole (5) at the bottom of the protective container.
 If necessary, replace the O-Ring for the pressure sensor (6).

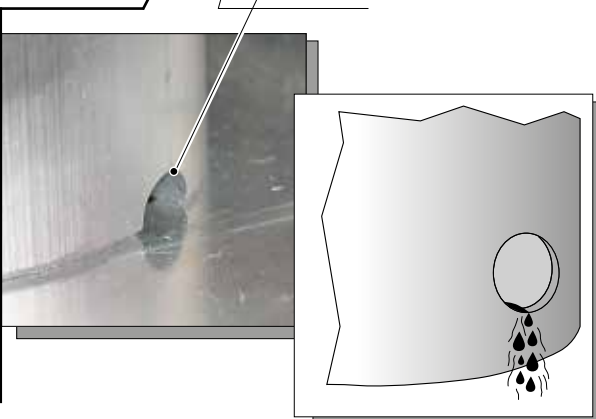
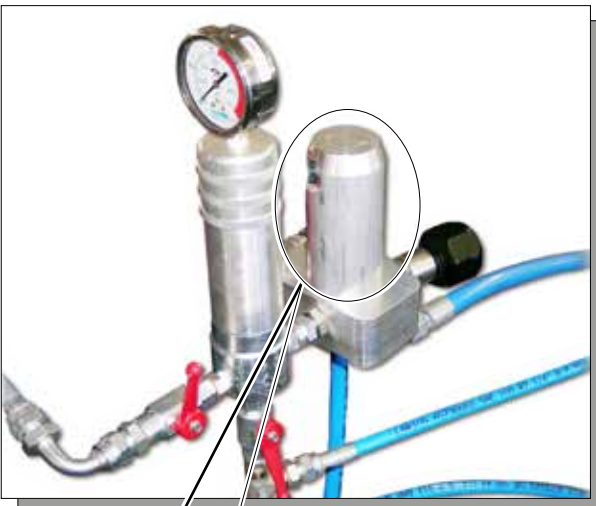

CHECKING THE MOTOR OIL

Check the motor oil every 100 working hours via the relevant measuring caps positioned on the bottom of the petrol motor.
 Top up if necessary.

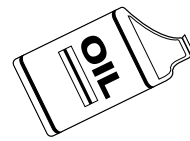

DESCRIPTION OF THE CONTROLS

- 1) **Directional lever**
Pull on the lever to release the linear drive lock (a) and allow the machine to perform curved line tracts.
- 2) **Blue luminous selector**
Activates the pneumatic circuit's compressor.
- 3) **Indicator light**
When on, indicates that the machine is ready for operation.
- 4) **Pressure regulation handle**
Allows the user to gradually regulate the pressure.
- 5) **Luminous selector**
Lifts or lowers the spray unit's stabilizing wheel.
- 6) **Indicator**
Displays the battery charge status.
- 7) **Speed regulation handle**
Allows the user to gradually regulate the machine's advancement speed.
- 8) **Alternator**
When the red indicator is on, it indicates a malfunction in the alternator required for charging the batteries.

- 9) **Direction selector**
Allows the user to select the machine's advancement direction; stops the machine's movement if pressed.
- 10) **Advancement**
- 11) **Light switch**
Activates/deactivates the frontal spotlight (if installed).
- 12) **Electric brake release**
When pressed, allows for the machine to be pushed in the event of electrical malfunction or blockage
- 13) **Spraying**
By pressing it, the manual spraying is enabled.
- 14) **Accelerator**
It gradually sets the number of revolutions of the internal combustion engine.

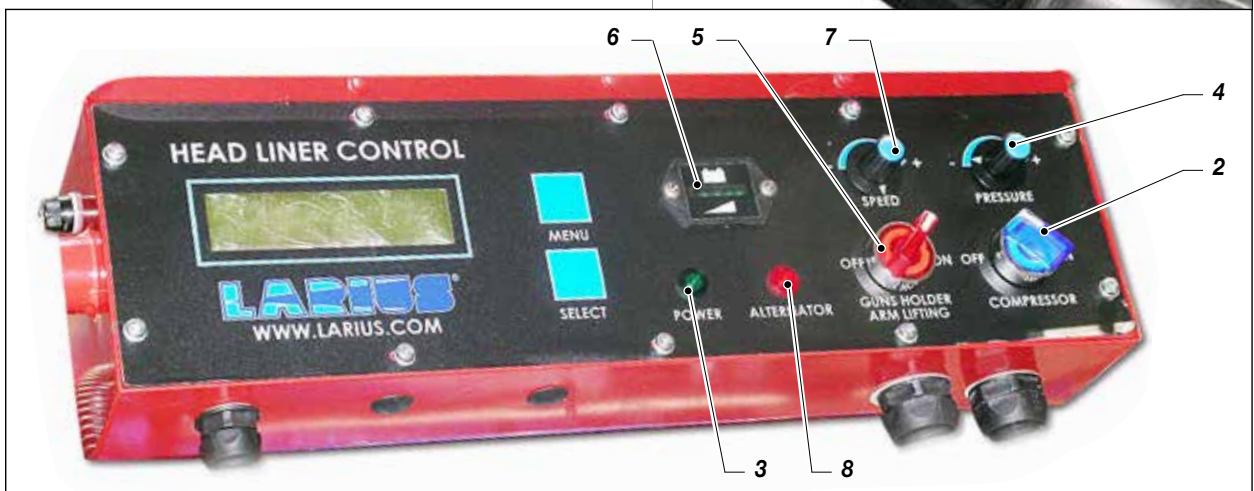
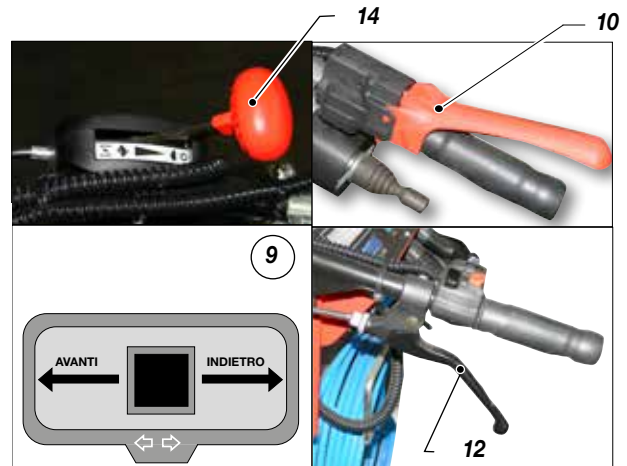
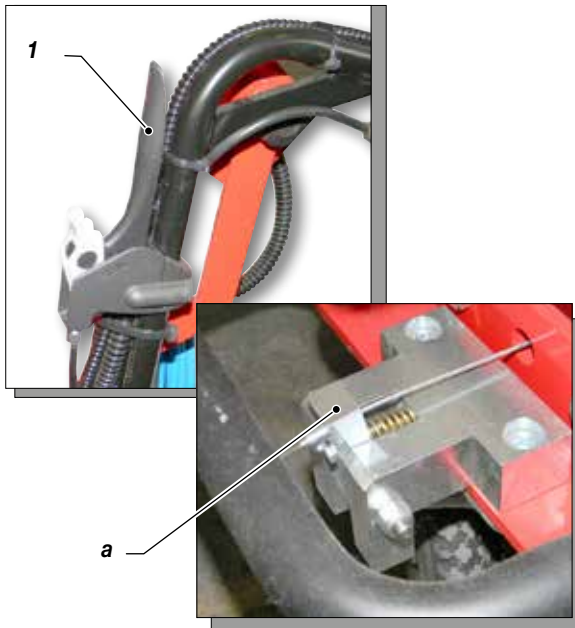

P EVEREST LINER CONTROL PANEL USE



Keep the pressure adjustment handle (O1) at minimum in order to access the various Menus.

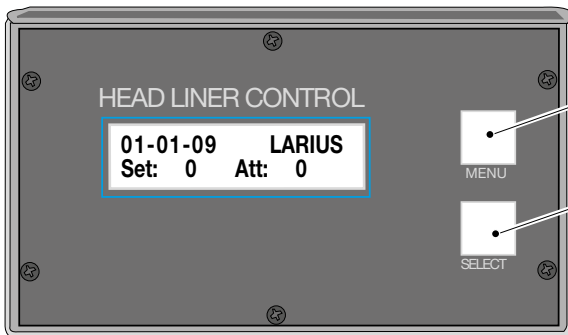

Display when the electronic box is switched on Fig.1

MENU key

SELECT key

- Activate by means of a special interrupter "0-1" on the right side of the control panel;
- On the display appear date, time and temperature (see Fig.1);
- Pressing the menu key will scroll through the list of functions 1 through 9.

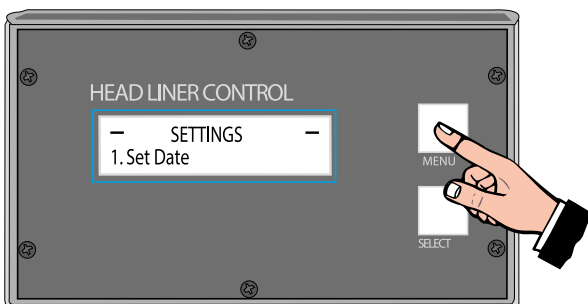

MENU 1: SETUP DATE

Press the "MENU" key and the first setting "1. DATE" will appear. To change the date:

- Press the "SELECT" key to enter the page;
- Press "MENU" to change the numbers for the date;
- Press "SELECT" to move from day to month and to year;
- Press "SELECT" when in the year position to return to point "1. DATE".

Press "MENU" to go on to point 2.

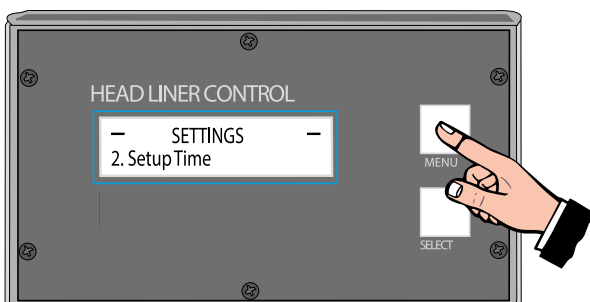

MENU 2: SETUP TIME

When "MENU" is pressed from point 1, the display reads "2. TIME".

To change the time:

- Press the "SELECT" key to enter the page;
- Press "MENU" to change the numbers for the date;
- Press "SELECT" to move from hour to minutes and seconds;
- Press "SELECT" when in the second position to return to point "2. TIME".

Press "MENU" to go on to point 3.



MENU 3: SETTING MAINTENANCE HOURS

When “MENU” is pressed from point 2, the display reads “3. MAINTENANCE HOURS”. This menu is used to set the n° of hours between successive maintenance tasks.

To change the time:

- Press the “SELECT” key to enter the page;
- Press “MENU” to increase the time set. Hold “MENU” down and press and release “SELECT” to invert the counter and therefore reduce the time set. ;
- Press “SELECT” again to return to point “3. MAINTENANCE HOURS”.

Press “MENU” to go on to point 4.



MENU 4: MAINTENANCE ALERT

When “MENU” is pressed from point 3, the display reads “4. MAINTENANCE ALERT”. This menu is used to set the n° of hours prior warning for maintenance tasks.

To change:

- Press the “SELECT” key to enter the page;
- Press “MENU” to increase the time set. Hold “MENU” down and press and release “SELECT” to invert the counter and therefore reduce the time set;
- Press “SELECT” again to return to point “4. MAINTENANCE ALERT”.

Press “MENU” to go on to point 5.

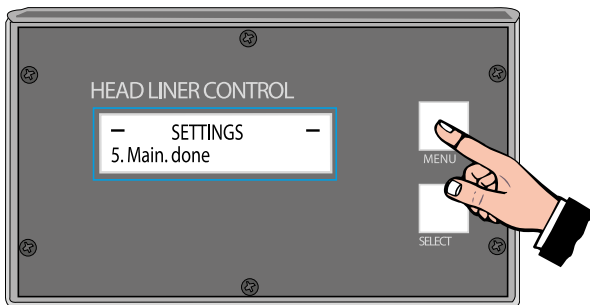

MENU 5: MAINTENANCE DONE

When “MENU” is pressed from point 4, the display reads “5. MAINTENANCE DONE”. This menu is used to reset the countdown after having completed maintenance.

To change:

- Press the “SELECT” key to enter the page;
- Press “SELECT” again to confirm that maintenance has been done. The display automatically goes back to menu “5. MAINTENANCE DONE”.

Press “MENU” to go on to point 6.

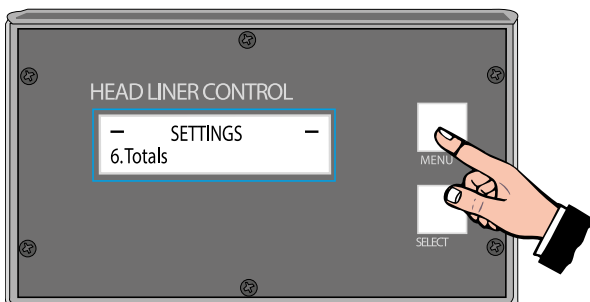

MENU 6: TOTALS

When “MENU” is pressed from point 5, the display reads “6. TOTALS”. This menu shows the number of hours worked and the number of times the pump control clutch has been activated.

- Press the “MENU” or “SELECT” key to return to “6. TOTALS”. Press “MENU” to go on to point 7.

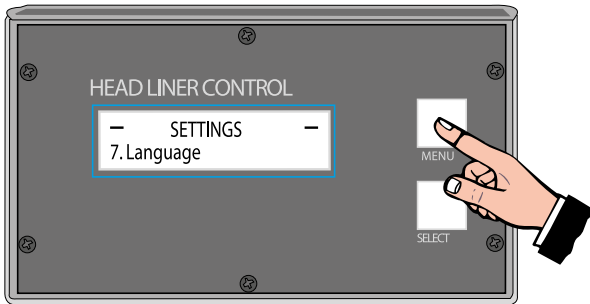

MENU 7: LANGUAGE

When “MENU” is pressed from point 6, the display reads “7. LANGUAGE”. This menu can be used to set the language.

- Press the “SELECT” key to access the page, and the “MENU” key to switch from Italian to English and from English to Italian;
- Press “SELECT” to return to “7. LANGUAGE”. Press “MENU” to go on to point 8.

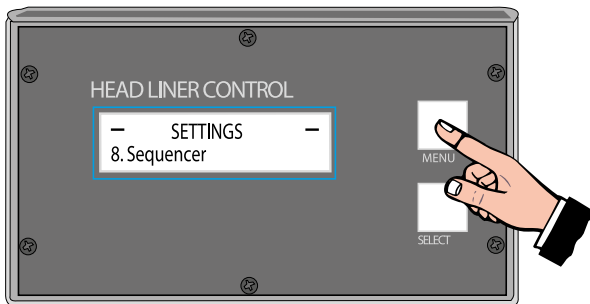

MENU 8: SEQUENCER

When “MENU” is pressed from point 7, the display reads “8. SEQUENCER”. This menu can be used to select or deselect the use of the automatic tracker.

- Press the “SELECT” key to access the page, and the “MENU” key to switch from sequencer YES or NO ;
- Press “SELECT” to return to “8. SEQUENCER”. Press “MENU” to go on to point 9.

N.B.: If “Sequencer YES” is selected the tracking setting menu described below can be accessed.

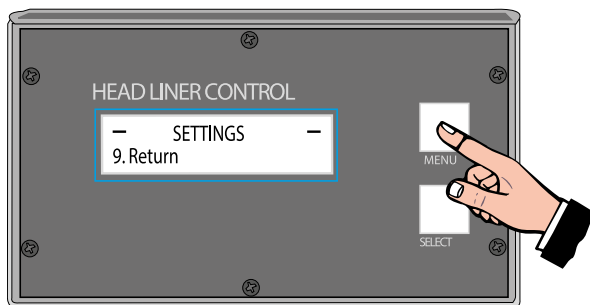

MENU 9: RETURN

When “MENU” is pressed from point 8, the display reads “9. RETURN”. This menu is used to go back to the initial page.

- Press the “SELECT” key to return to the initial page.

Q LINE SEQUENCING FUNCTION

From the initial page, if the “MENU” key is pressed twice, the “spray menu” mode is accessed spray menu (*N.B. Only if Menu 8 was previously set to “Sequencer ON”*).

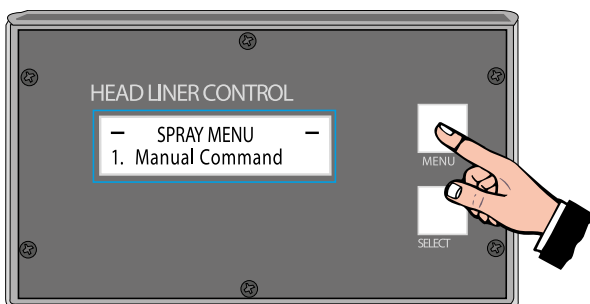

MENU 1: MANUAL COMMAND

This function allows one to decide which gun to use with the control lever in the “continuous” position. The possibilities are:

- Gun SX only;
- Gun DX only;
- Guns SX and DX simultaneously;
- Press the menu button to change setting;
- Press the select key to exit.

N.B.: this menu refers only to the “MANUAL” (“MAN”).

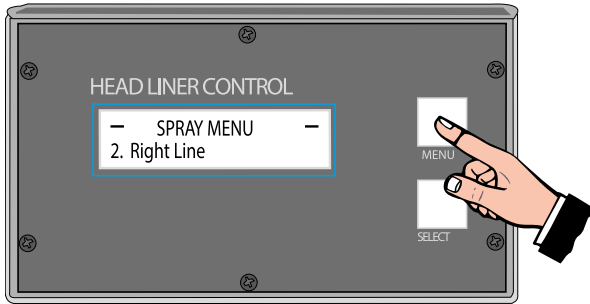

MENU 2: RIGHT LINE

This function allows for the programming of the length of the dashed line.

- Press menu key until arriving at page 2;
- Press select key to enter the page;
- Press the menu key to increase the set value;
- Hold “MENU” down and press and release “SELECT” to invert the counter (and therefore reduce the value set).
- Press select to exit.

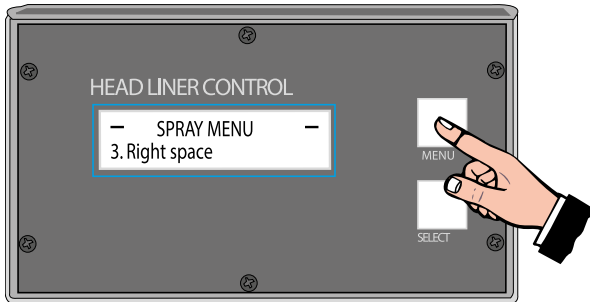

MENU 3: RIGHT SPACE

This function allows for the programming of the length of the blank area between dashes.

- Press menu key until arriving at page 3;
- Press select key to enter the page;
- Press the menu key to increase the set value;
- Hold “MENU” down and press and release “SELECT” to invert the counter (and therefore reduce the value set).
- Press select to exit.

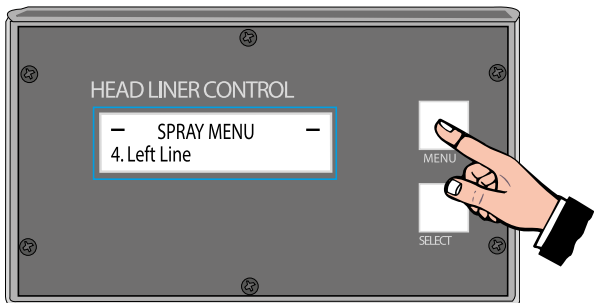

MENU 4: LEFT LINE

This function allows for the programming of the length of the dashed line.

- Press menu key until arriving at page 4;
- Press select key to enter the page;
- Press the menu key to increase the set value;
- Hold “MENU” down and press and release “SELECT” to invert the counter (and therefore reduce the value set).
- Press select to exit.

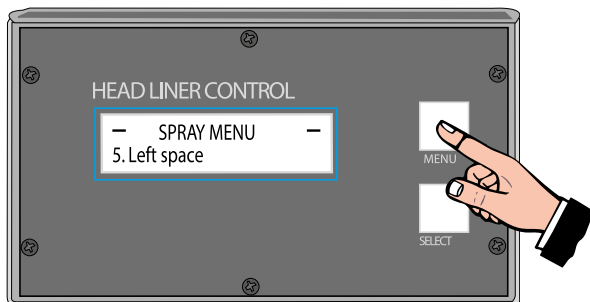

MENU 5: LEFT SPACE

This function allows for the programming of the length of the blank area between dashes.

- Press menu key until arriving at page 5;
- Press select key to enter the page;
- Press the menu key to increase the set value;
- Hold “MENU” down and press and release “SELECT” to invert the counter (and therefore reduce the value set).
- Press select to exit.

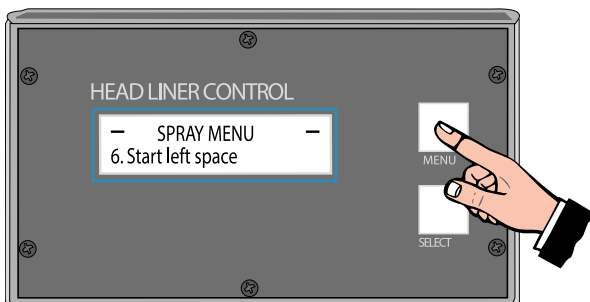

MENU 6: START LEFT SPACE

This function allows for the spray delay to be set exclusively for the left gun.

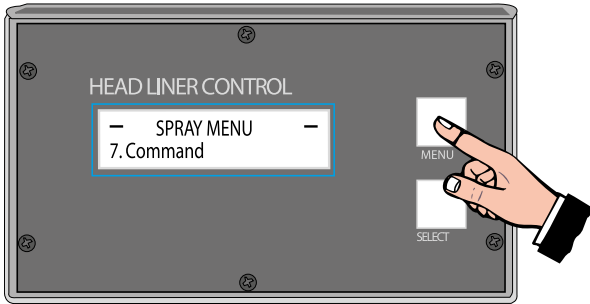

MENU 7: COMMAND

This function allows one to stabilize which guns will be used with the lever in the “AUTOMATIC” (“AUT”) position.

- Press menu key until arriving at page 7;
- Press the select key to enter the page.

Possible settings are:

- Gun SX off + DX dashed;
- Gun SX off + DX continuous;
- Gun SX dashed + DX dashed;
- Gun SX dashed + DX continuous;
- Gun SX continuous + DX dashed
- Press the menu key to choose the desired setting;
- Press select to exit.

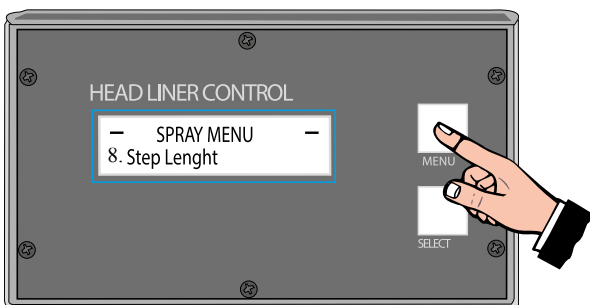

MENU 8: STEP LENGTH

This function is used to correct any errors that may occur between the dotted line entered and the line actually made.

- Press the “MENU” key until page 9 is reached;
- Press the “SELECT” key to enter the page;
- Press the “MENU” key to increase the value set (*the line length is reduced*);
- Hold “MENU” down and press and release “SELECT” to invert the counter (and therefore reduce the value set). The length of the line increases;
- Press “SELECT” to exit.

N.B.: the step length is already set in the factory and generally does not need to be changed

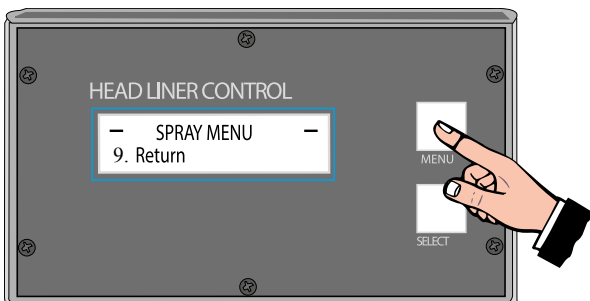

MENU 9: RETURN

This function is used to go back to the initial page.

- Press the “MENU” key until page 10 is reached;
- Press the “SELECT” key to return to the initial page.

Once the various options have been set, it is possible to change from a continuous line to a dotted line while the machine is running by simply changing the position of the control lever:

AUT = AUTOMATIC (works using the settings in menu “2. LINE” and “3. SPACE”).

MAN = MANUAL (works using the settings in menu “1. MANUAL COMMAND”).

R SPACE AND LINE SETTINGS

 The **SPACE** and **LINE** measurement settings for the LH-RH guns have been taken to the second decimal resolution. Values of the following type can therefore be set: MT 1.54.

- Possibility of programming the RH SPACE and RH LINE, LH SPACE and LH LINE independently.
- Introduced the DELAY SPRAYING LH gun parameter. The DELAY SPRAYING LH gun is only read by the programme once from when the spray control lever is enabled (AUT).

Example of programming to obtain the spray shown in "Figure 1"

RH line	2 MT
RH space	1 MT

LH line	1 MT
LH space	2 MT

LH delay spraying	0,5 MT
Control	LH=T RH=T

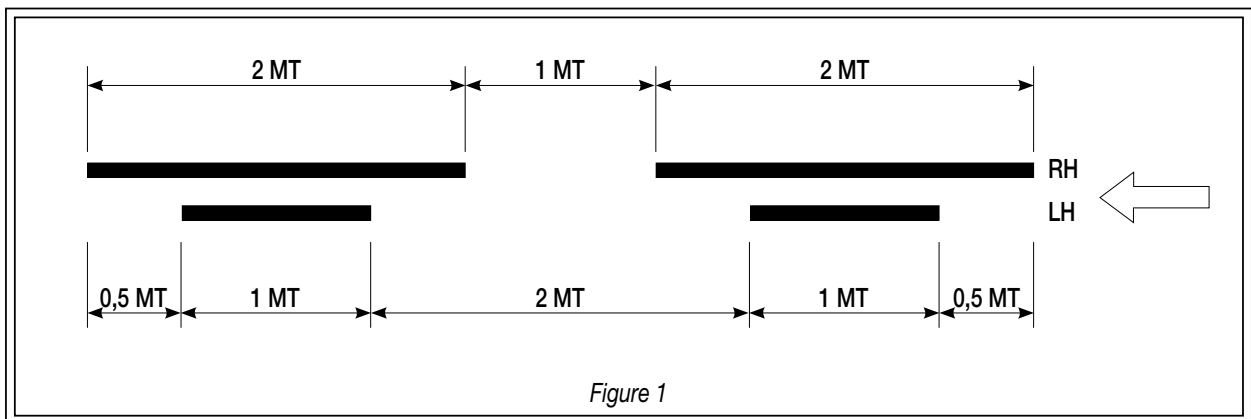

Example of programming to obtain the spray shown in "Figure 2"

RH line	2 MT
RH space	2 MT

LH line	0,4 MT
LH space	2,6 MT

LH delay spraying	0,3 MT
Control	LH=T RH=T

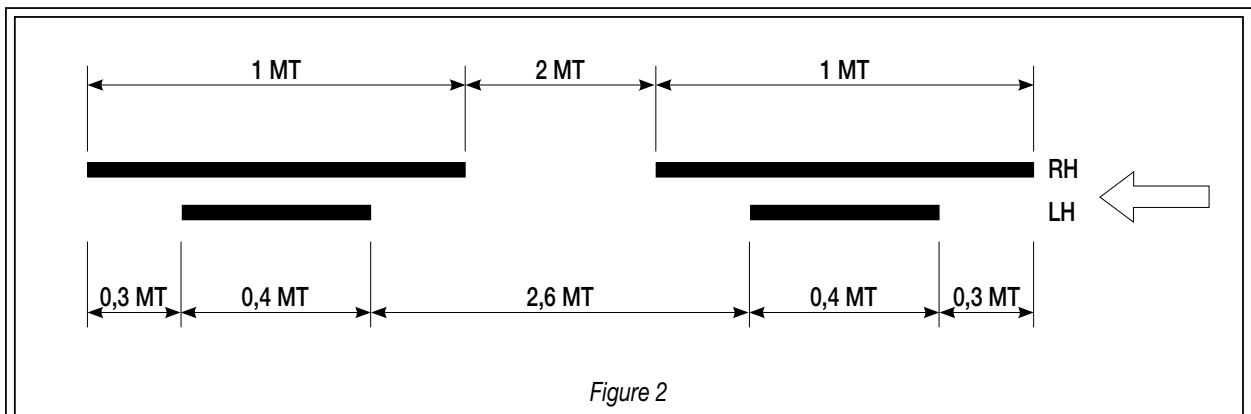

Example of programming to obtain the spray shown in "Figure 3"

RH line	1 MT
RH space	1 MT

LH line	1 MT
LH space	1 MT

LH delay spraying	0 MT
Control	SX=T DX=T

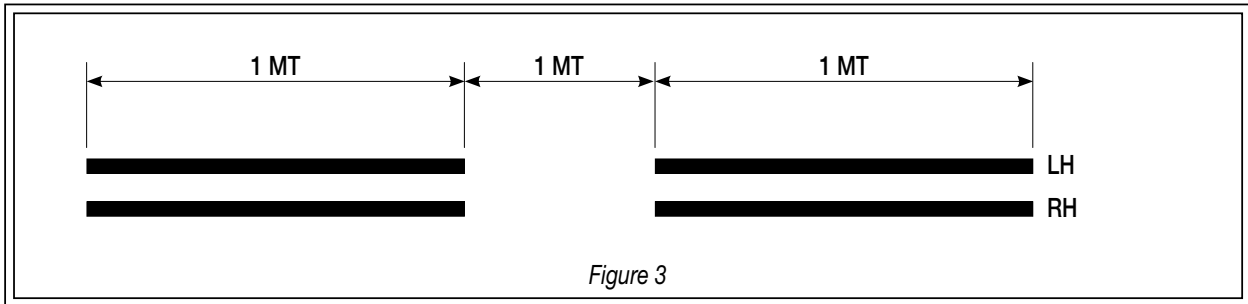

Example of programming to obtain the spray shown in "Figure 4"

RH line	1 MT*
RH space	1 MT*

LH line	1 MT
LH space	1 MT

LH delay spraying	0 MT
Control	SX=T DX=C

*Not considered as the RH gun is in continuous mode

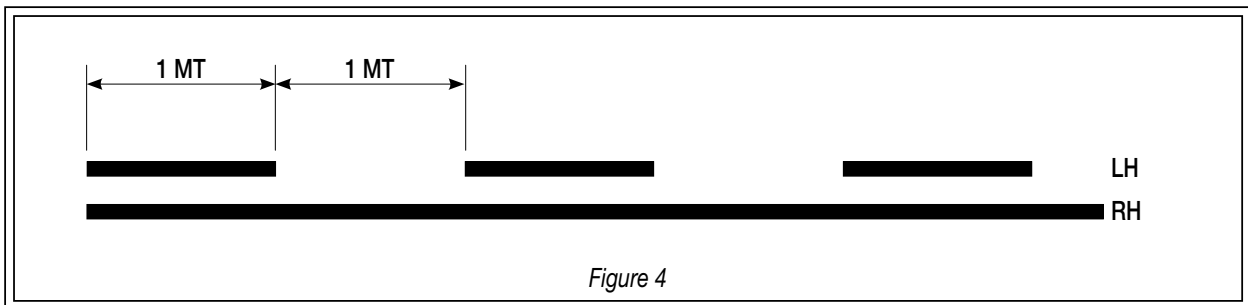

Programming of other spray types has remained unchanged.

Example of programming to obtain the spray shown in "Figure 5"

RH line	1 MT
RH space	1 MT

LH line	0,5 MT
LH space	1,5 MT

LH delay spraying	0 MT
Control	SX=T DX=T

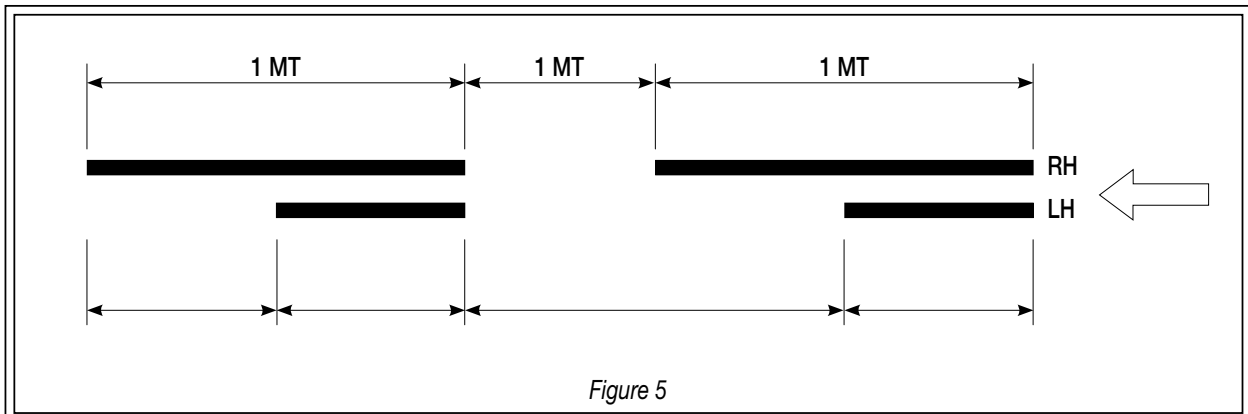

S PROBLEMS AND SOLUTIONS

Problem	Cause	Solution
<ul style="list-style-type: none"> Engine won't start 	<ul style="list-style-type: none"> The petrol manifold is closed; Engine is out of gas; Cold engine; Spark plug cable is disconnected or damaged; 	<ul style="list-style-type: none"> Open the petrol manifold; Refill gas tank; Use choke; Connect spark plug cable or replace spark plug;
<ul style="list-style-type: none"> The equipment does not start 	<ul style="list-style-type: none"> On/Off switch disconnected; Breakdown of pressure transmitter; Breakdown of motor electric control box; The line of material coming out of the pump is already under pressure; The product is solidified inside the pump; 	<ul style="list-style-type: none"> Ensure the On/Off switch is on the "on" position and turn clockwise the pressure control knob; Verify and replace it, if necessary; Verify and replace it, if necessary; Open the drain valve to release pressure in the circuit; Open the drain valve to release pressure in the circuit and stop the machine. Disassemble the pumping group and the pressure transmitter and clean;
<ul style="list-style-type: none"> The equipment does not suck the product 	<ul style="list-style-type: none"> Suction filter clogged; Suction filter too fine; The equipment sucks air; 	<ul style="list-style-type: none"> Clean or replace it; Replace it with a larger-mesh filter (<i>with very dense products, remove the filter</i>); Check the suction pipe;
<ul style="list-style-type: none"> The equipment sucks but does not reach the pressure desired 	<ul style="list-style-type: none"> Lack of product; The equipment sucks air; The drain valve is open; The gaskets of the pumping group are worn; Suction or delivery valve dirty; 	<ul style="list-style-type: none"> Add the product; Check the suction pipe; Close the drain valve; Replace the gaskets; Disassemble the pumping group;
<ul style="list-style-type: none"> When pressing the trigger, the pressure lowers considerably 	<ul style="list-style-type: none"> Nozzle too big or worn; The product is too dense; The filter of the gun-butt is too fine; 	<ul style="list-style-type: none"> Replace it with a smaller one; Dilute the product, if possible; Replace it with a larger-mesh filter;
<ul style="list-style-type: none"> The pressure is normal but the product is not atomized 	<ul style="list-style-type: none"> The nozzle is partially clogged; The product is too dense; The filter of the gun-butt is too fine; 	<ul style="list-style-type: none"> Clean or replace it; Dilute the product, if possible; Replace it with a larger-mesh filter;
<ul style="list-style-type: none"> The atomization is imperfect 	<ul style="list-style-type: none"> The nozzle is worn; 	<ul style="list-style-type: none"> Replace it;
<ul style="list-style-type: none"> When releasing the trigger of the gun, the equipment does not stop (<i>the motor runs slowly and the piston rod keeps on going up and down</i>) 	<ul style="list-style-type: none"> The gaskets of the pumping group are worn; Suction or delivery valve dirty; Drain valve defective; 	<ul style="list-style-type: none"> Replace the gaskets; Disassemble the pumping group and clean; Verify and replace it, if necessary;

T CORRECT PROCEDURE OF DECOMPRESSION

- Move the switch (1) to the OFF (0) position to stop the equipment.

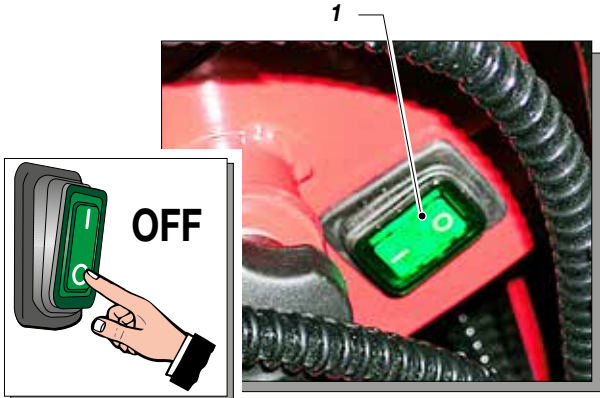

- Unlock the safety clamp (2).

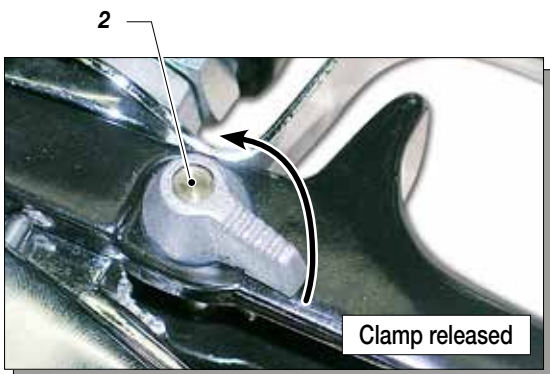

- Point the gun (3) at the receptacle (4) used to collect the product and press the trigger to release the pressure. When completed, activate the safety catch again.

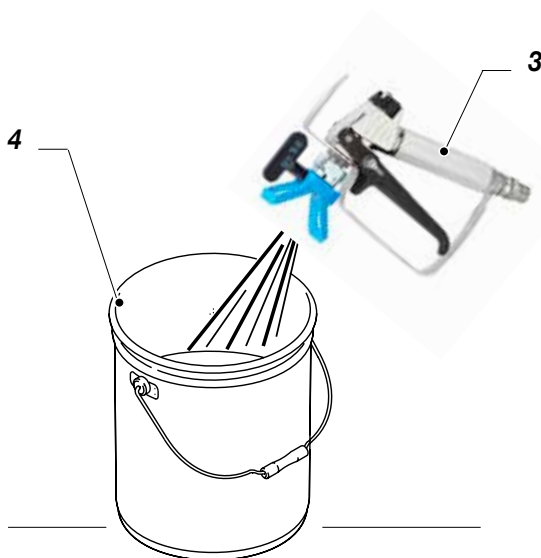

- Open the discharge valve (5) to release the remaining pressure.

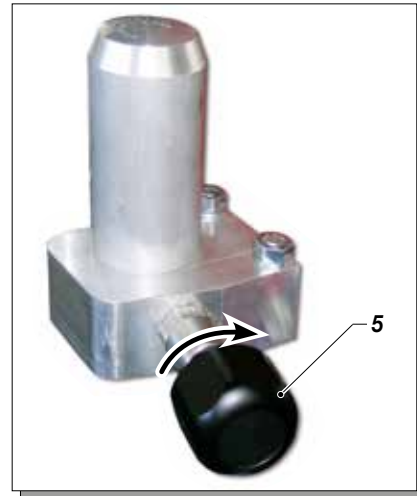

WARNING:

If the equipment is still under pressure after performing the operations above described because of the nozzle or the flexible hose clogged, proceed as follows:



- Loosen very slowly the gun nozzle.
- Release the clamp.
- Point the gun at the container of the product and press the trigger to release pressure.
- Loosen very slowly the fitting of connection from the flexible hose to the gun.
- Clean or replace the flexible hose and the nozzle.

U REPLACEMENT OF THE PUMPING GROUP GASKETS

Each time you use the machine, check for material leaking from the top of the ring nut.

If any material leaks out when the pump is working at the set pressure, proceed as follows:



Always disconnect the power supply and release pressure before going on with the operations (follow the "correct procedure of decompression").

 **The gaskets are self-adjusting. If a leak occurs they must be replaced.**

- Disconnect the product feed hose (1) from the pump unit by unscrewing the nut (2).
- Unscrew the fixing ring nut (3) using the relevant closing pin (Ref. 20144).

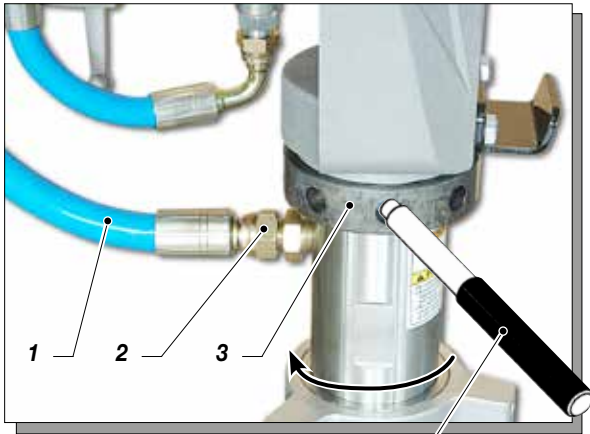

Ref. 20144

- Release the plastic cover (4).



- Put the switch (5) ON (I) for the equipment.

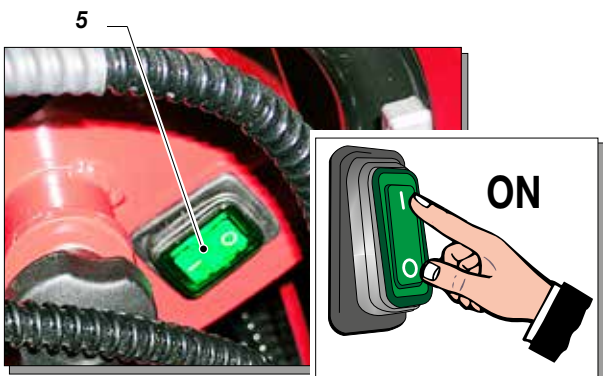

- Increase pressure (6) to the minimum in order to apply the clutch and allow the piston to move.

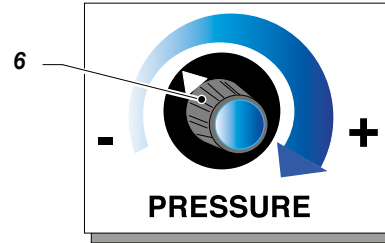

- Pull the ignition belt (7) lightly until the piston rod has been brought to the lowest point of its stroke.
- Put the switch (5) OFF (0) for the equipment.



- Screw the appropriate supplied tool (8 - ref- 20213) into the threaded hole on the holding pin (9).

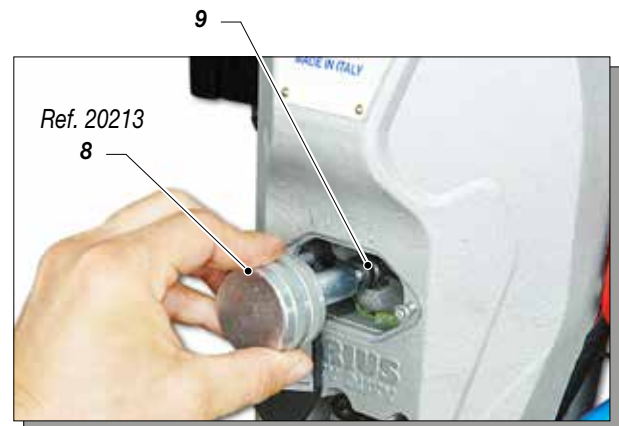

- Remove the pin (9) from its seating.

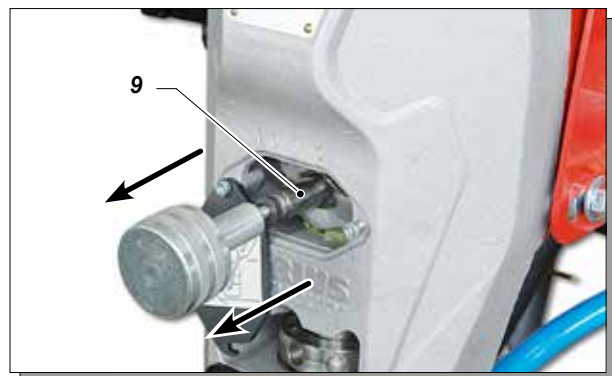

- Unscrew the pump unit (10) from the frontal flange (11).



Lower seal

- Remove the piston stem (12) and remove the pump unit sleeve (13);

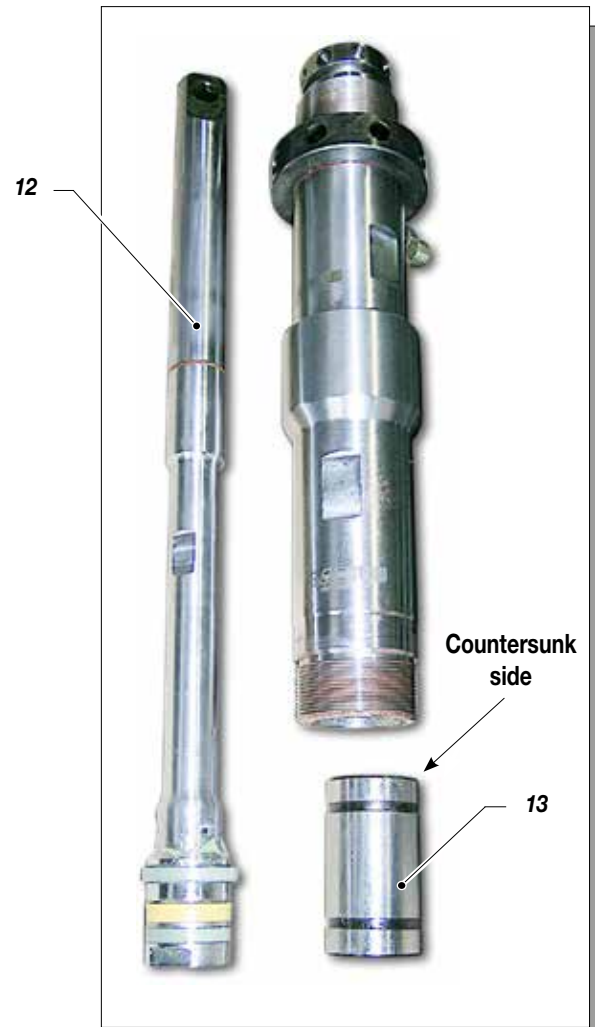

PIT STOP MAINTENANCE

Replacement of upper and lower gaskets 20 minutes.

- Lock the pump unit into a vice and unscrew it with a 60 mm wrench;
- Release the pump unit from the body of the suction valve;



- Grip the stem valve (14) in a vice;

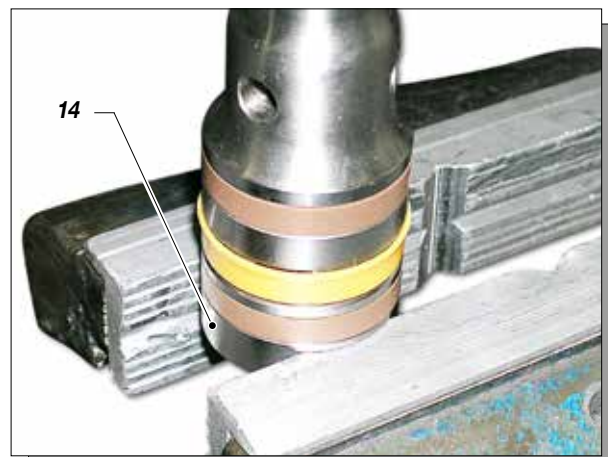

- Use a size 24 spanner to unscrew the lower stem (15);

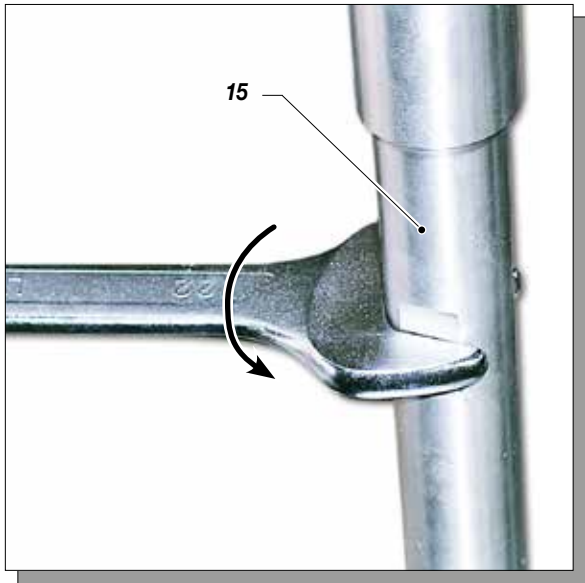

- Unscrew the stem valve (17) altogether, check the surface of the ball seating (18) that comes into contact with the ball (19).
If worn, replace them;



- Use a screwdriver to remove the two open-ring guide bands (16) and replace them;

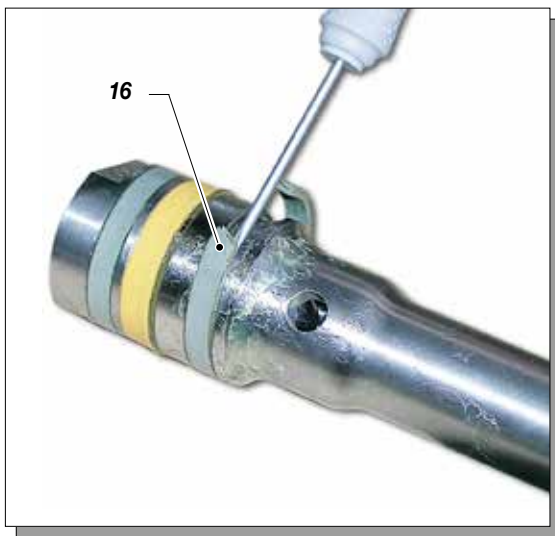

- Use a screwdriver to remove the O-Ring (U20) and replace it making sure it is aligned correctly (as illustrated);

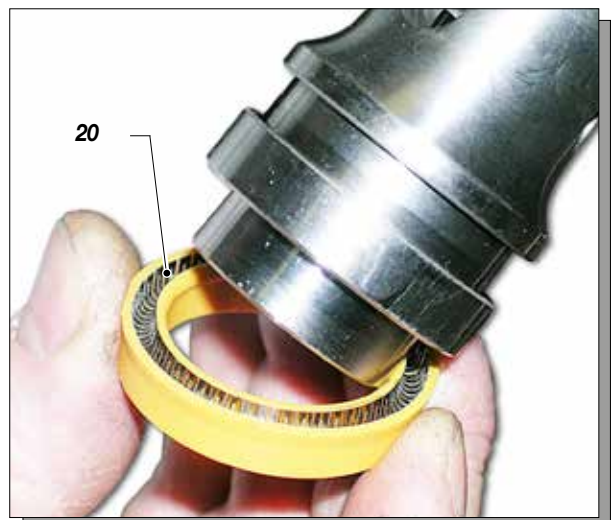
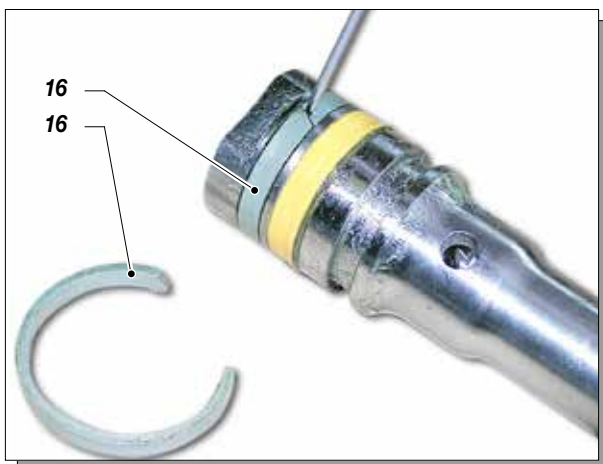

- Screw the valve stem (17) (Ref. 20139) on again and tighten fully, gripping the valve in a vice. To tighten, use a 22 mm spanner;
The use of a thread paste is recommended;

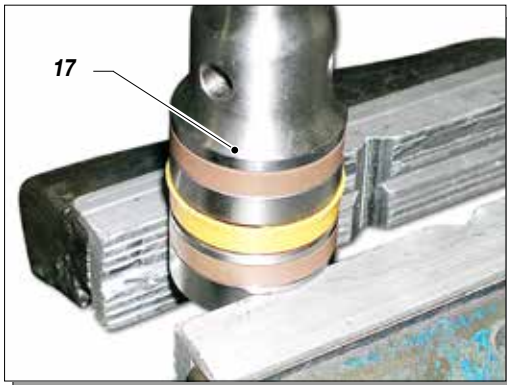

Upper seal

- Remove the ring nut (21);



- Remove the guide band (22) with a screwdriver and replace it with a new one;

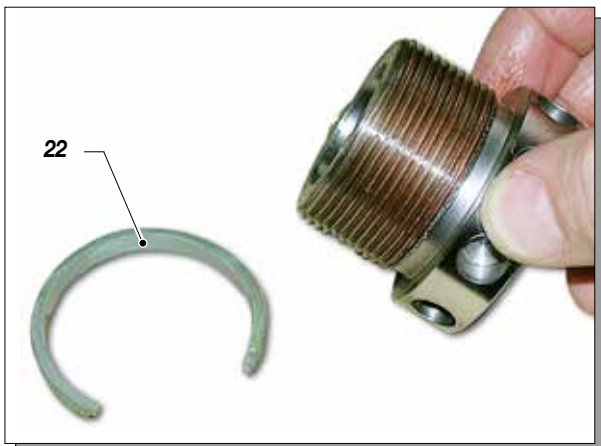

- Remove the seal (23) with a screwdriver;



- Using a screwdriver, remove the second band (24) located below the seal (23) and insert a new band in the same position;



The positioning of the seal (23) requires special care during assembly.

- Assist insertion by applying leverage to the outside of the ring (23), pushing from the outside inwards and helping the ring to lodge in the seating, while being careful not to damage the ring's contact surfaces.



Lubricate with grease before fitting.

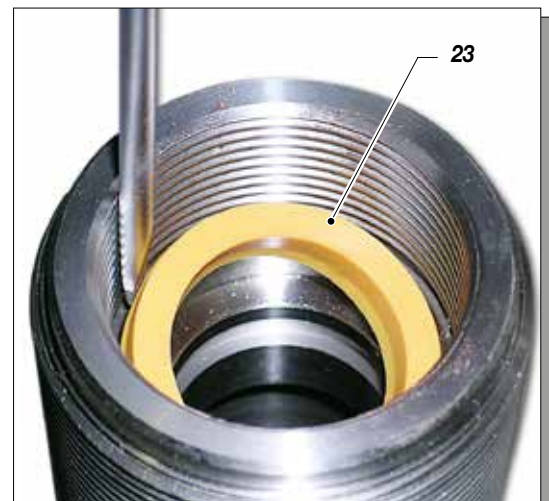

- Remove the OR (25) of the footvalve (26) and the sealing ring (27) and, if necessary, replace. Reassemble the components in their proper order (as indicated in the diagram);

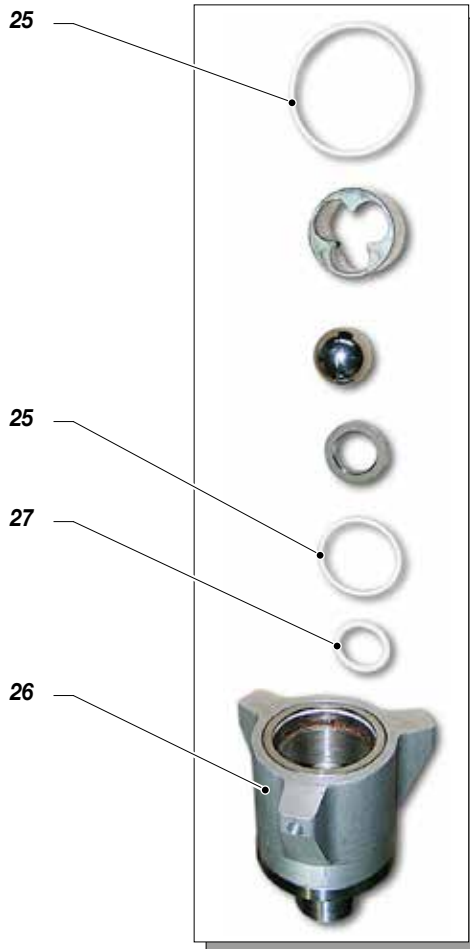

! To facilitate fitting the O-ring (27) it is advisable to warm it slightly with a blast of hot air.

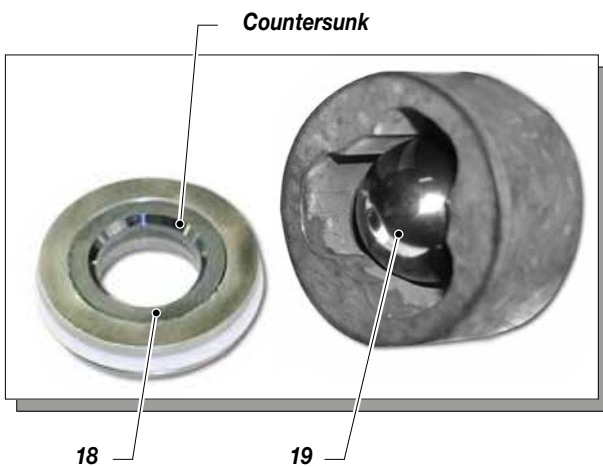

! The ball seating (18) is countersunk on one side, where the ball (19) must sit.

- Screw the locking ring nut (21) back onto the body of the pump unit until it makes contact, then loosen it by one turn;



- Remove the sleeve/cylinder seal (28) and replace it with a new one;



- Check the wear status of the surfaces inside the jacket. Replace it if necessary;
- Grease the sleeve (29) using a paintbrush;

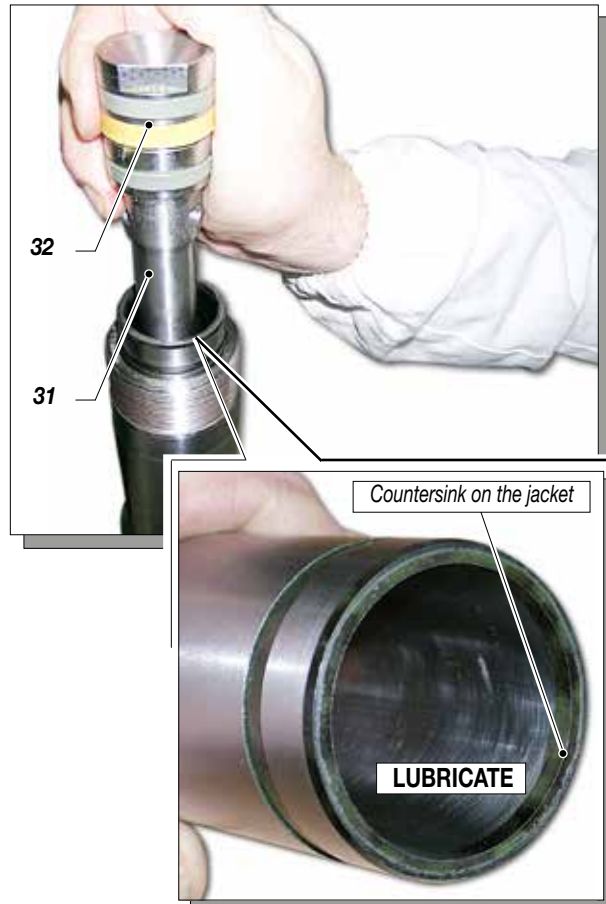

- Insert the sleeve (29) into the lower pump unit (30);

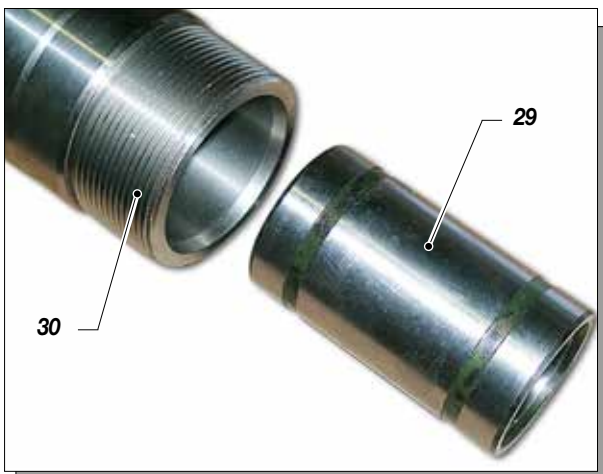

- Screw on the complete foot valve (26) with the sleeve assembly (28);



In order to guarantee a proper seal, tighten the foot valve (26) fully, using a 50 mm spanner.



Insert the complete piston stem (31) after greasing the gaskets (32).

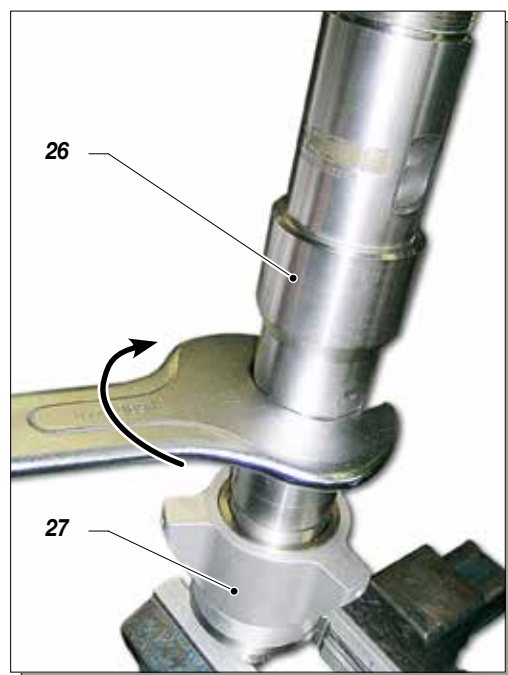

- When refitting the pump unit on the machine, the stem must be at its highest point possible.
- Insert the stem into the connecting rod and insert the fixing pin (9).



- Lubricate the upper crown (36) using oil (37) (Ref. 16325);



- Tighten the pump casing all the way and, if the delivery pipe is not correctly aligned, unscrew the pump casing until the connection is in the correct position before tightening by using the ring nut (U33) and the pin (34) supplied (Ref. 20144).

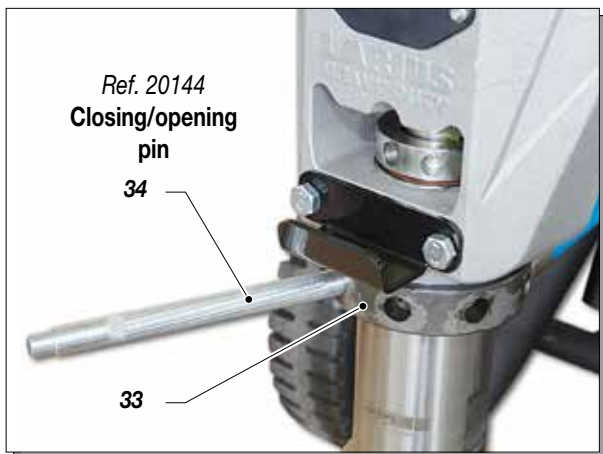

- Refit the inspection barrier (38);

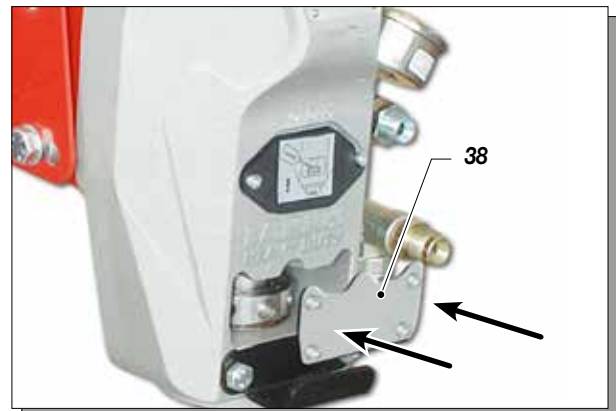

- Close the seal ring nut (35) all the way.



- To assemble all the parts in the correct sequence, see the exploded diagram.



Intentionally blank page

SPARE PARTS

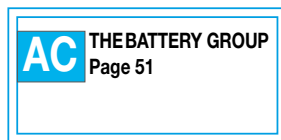
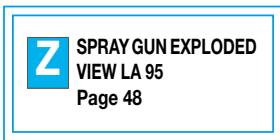
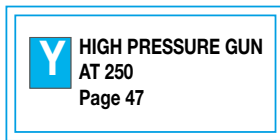
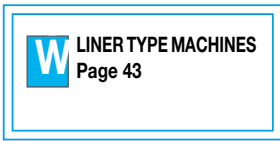
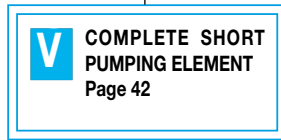
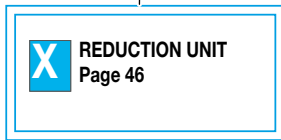
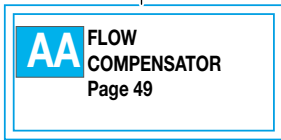
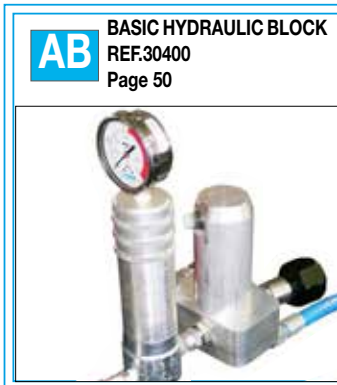

V COMPLETE SHORT PUMPING ELEMENT

WARNING: Contact the manufacturer always indicating code and quantity for each part required.

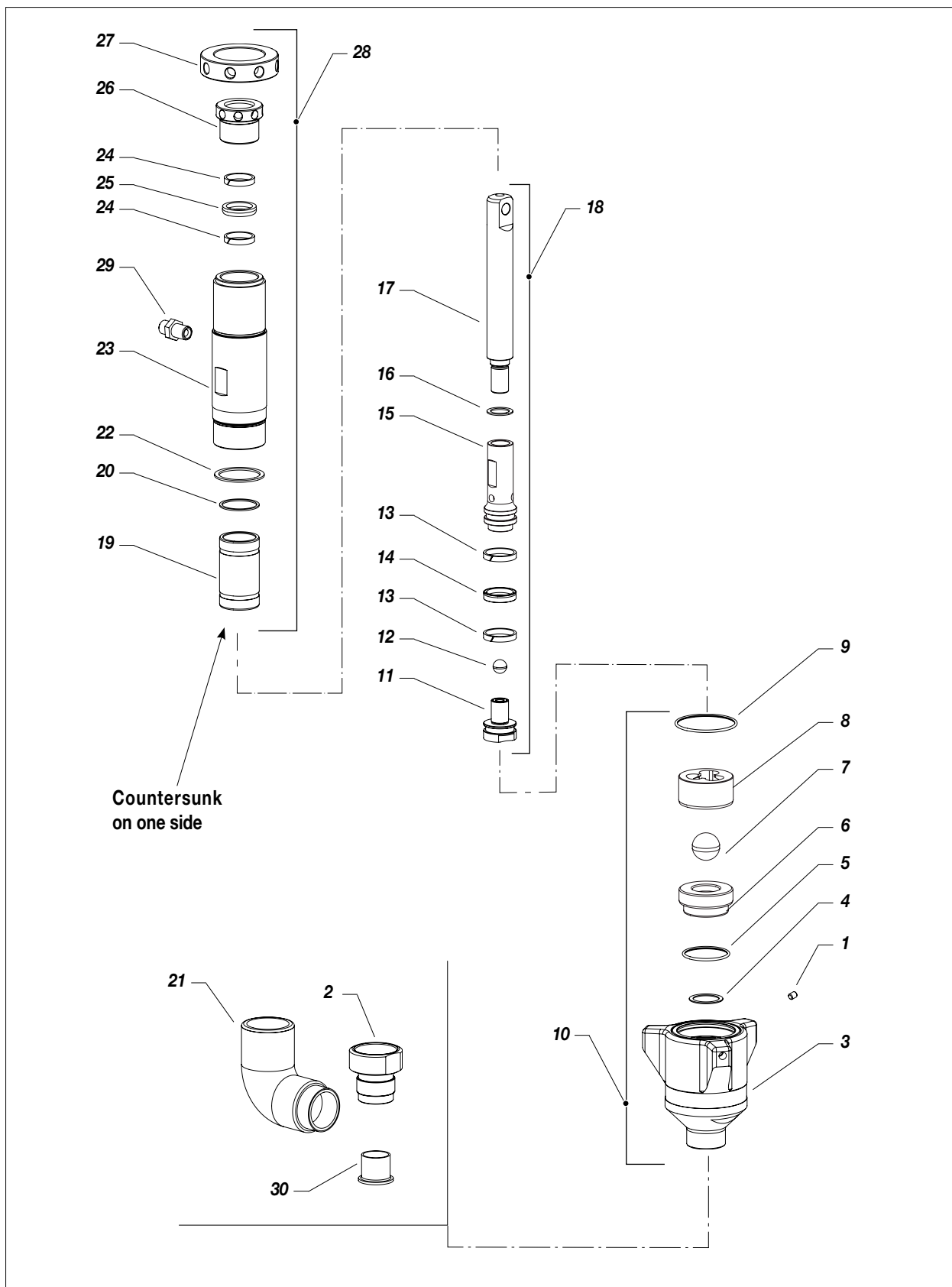

Pos.	Code	Description	Q.ty	Pos.	Code	Description	Q.ty
-	-	Complete short pumping element heavy products	1	15	20116	Short stem	1
1	81106	Dowel	3	16	20106	Sealing	1
2	19295	Suction pipefitting	1	17	20107	Upper stem	1
3	20130	Assembled valve	1	18	20137	Heavy products stem assembly	1
4	19296	Sealing	1	18	20146	Standard products stem assembly	1
5	20131	OR	1	19	20108	Sleeve	1
6	20143	Ball housing assembly	1	20	20109	Sleeve-cylinder seal	1
7	20148	Ball	1	21	20172	90° bend	1
8	19297	Ball guide	1	22	20111	Sealing	1
9	20132	OR	2	23	20112	Upper pump unit casing	1
10	20133	Heavy products footvalve unit assembly	1	24	20138	Upper guide band	2
10	20145	Standard products footvalve unit assembly	1	25	20139	Upper gasket	1
11	20134	Stem valve assembly	1	26	20113	Ring nut	1
12	16120	Ball	1	27	20114	Tightening ring nut	1
13	20135	Lower seal bands	2	28	20140	Heavy products jacket assembly	1
14	20136	Lower gasket	1	28	20147	Standard products jacket assembly	1
				29	34109	Adapter	1
				30	96099	Seal sleeve	1

W LINER TYPE MACHINES

NOTES ON THE ASSEMBLY OF THE CLUTCH UNIT

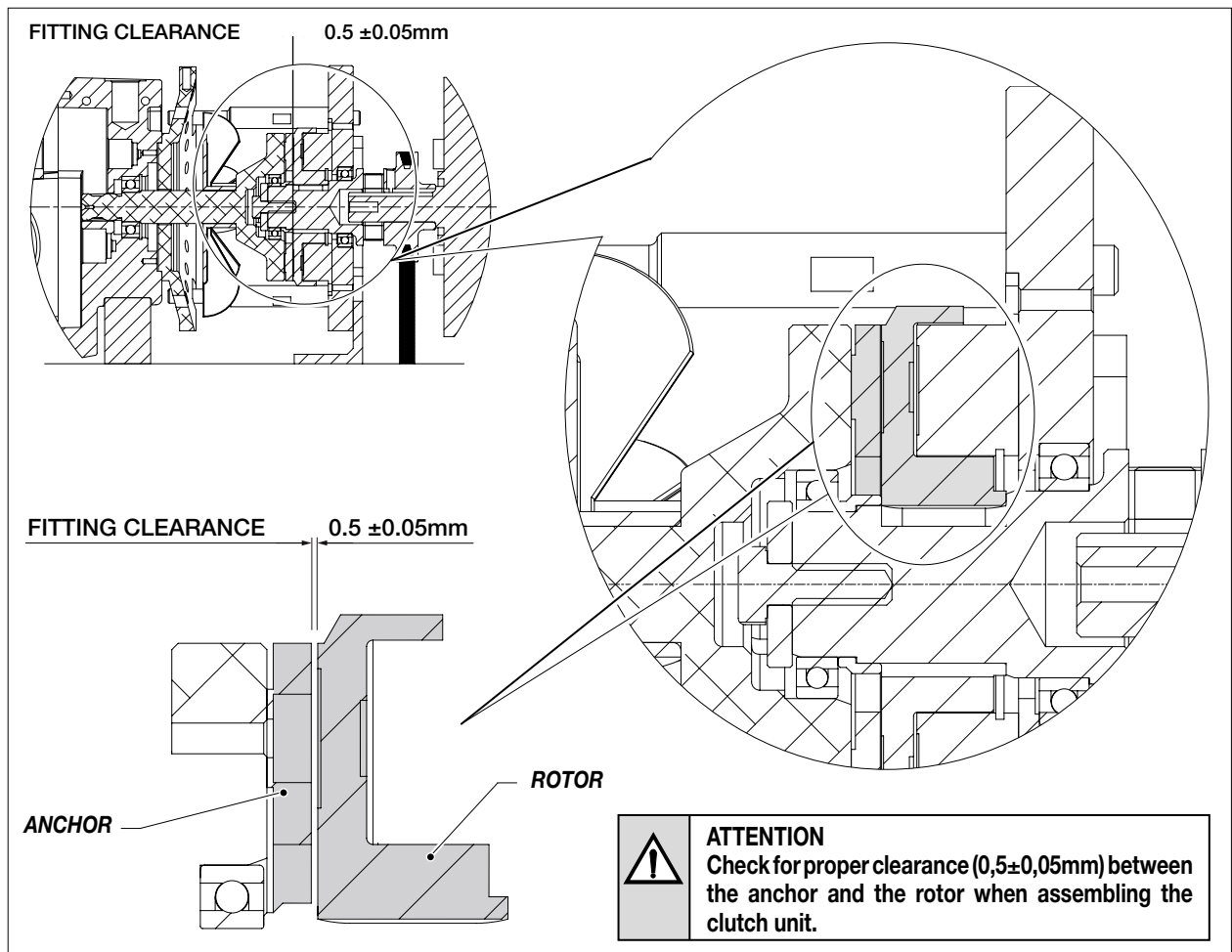

WARNING: Contact the manufacturer always indicating code and quantity for each part required.

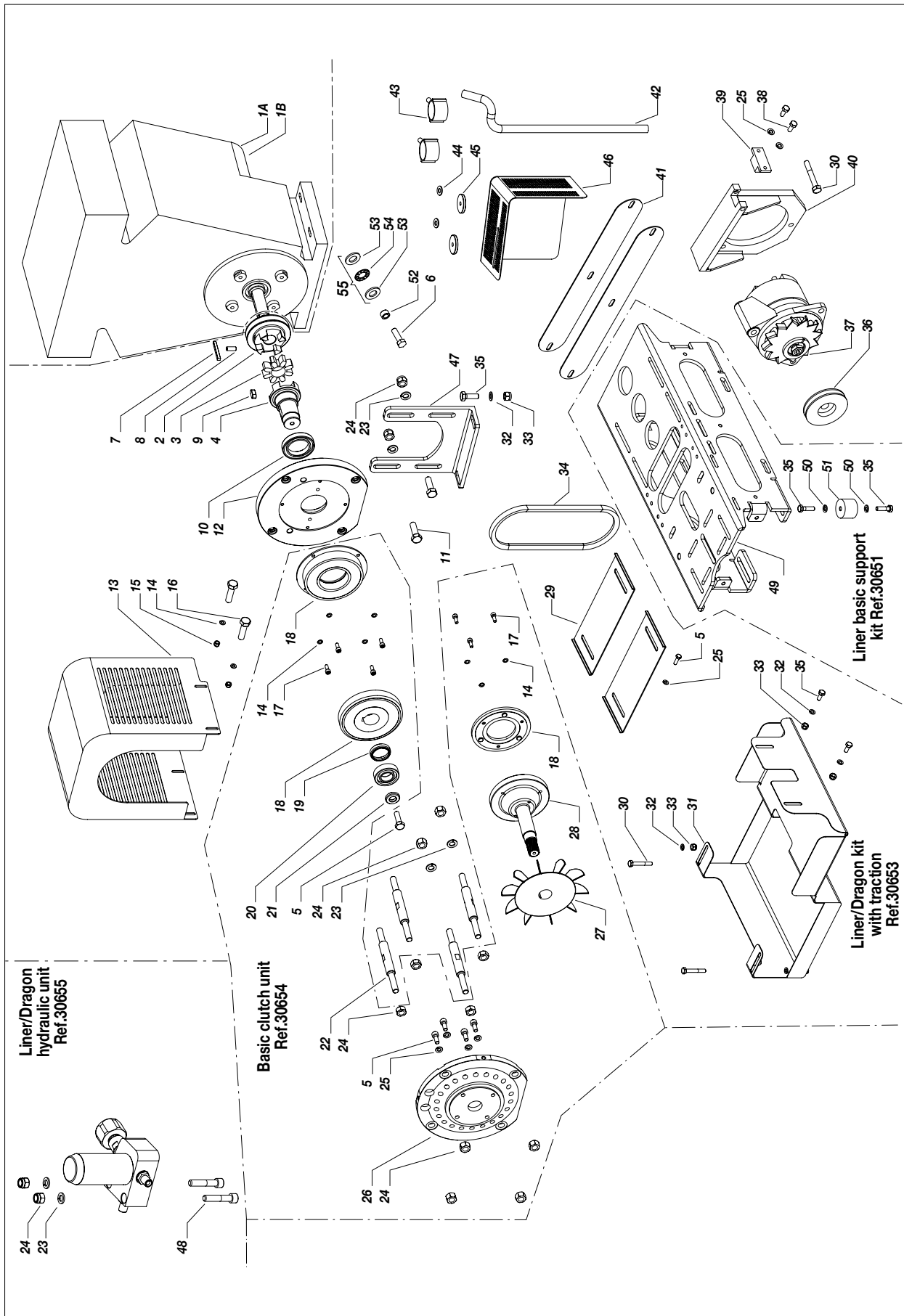

Pos.	Code	Description	Q.ty	Pos.	Code	Description	Q.ty
1A	18186	Motor	1	28	18492	Pinion	1
1B	18187	Motor	1	29	18467	Safety shields	2
2	18473	Motor pulley-joint	1	30	83004	Screw	5
3	81038	Flexible coupling	1	31	18469	Guard	1
4	18474	Clutch-joint	1	32	95096	Washer	14
5	34008	Screw	10	33	96080	Self-tightening nut	6
6	18192	Screw	1	34	4752	Alternator belt	1
7	18189	Shaft tab	1	35	4409	Screw	12
8	81009	Dowel	1	36	4777/1	Alternator pulley	1
9	30656	Tab	1	37	4758	Alternator	1
10	30657	Bearing	1	38	8371	Screw	2
11	7112	Screw	2	39	4771	Alternator fulcrum	1
12	18477	Flange motor	1	40	4776	Alternator plate	1
13	18476	Guard	1	41	30667	Safety shields	2
14	54003	Washer	13	42	30690	Drain pipe	1
15	8042	Self-tightening nut	12	43	1000506	1" collar	2
16	16064	Screw	4	44	510068	Washer	2
17	54004	Screw	7	45	95153	Washer	2
18	18491	Complete clutch	1	46	30691	Safety cover	1
19	18490	Spacer ring	1	47	18471	Support plate	1
20	30659	Bearing	1	48	30451	Screw	2
21	30686	Locking ring	1	49	18472	Support plate	1
22	18475	Tie-rods	4	50	95096	Washer	6
23	95066	Washer	12	51	20537	Vibration-damping pad	4
24	5756	Self-tightening nut	12	52	18459	Support bush	1
25	96030	Washer	6	53	18452	Fifth wheel	2
26	20510	Reduction gear flange	1	54	18453	Axial roller cage	1
27	20531	Fan	1	55	18454	R.S. bearing unit	1

X REDUCTION UNIT

WARNING: Contact the manufacturer always indicating code and quantity for each part required.

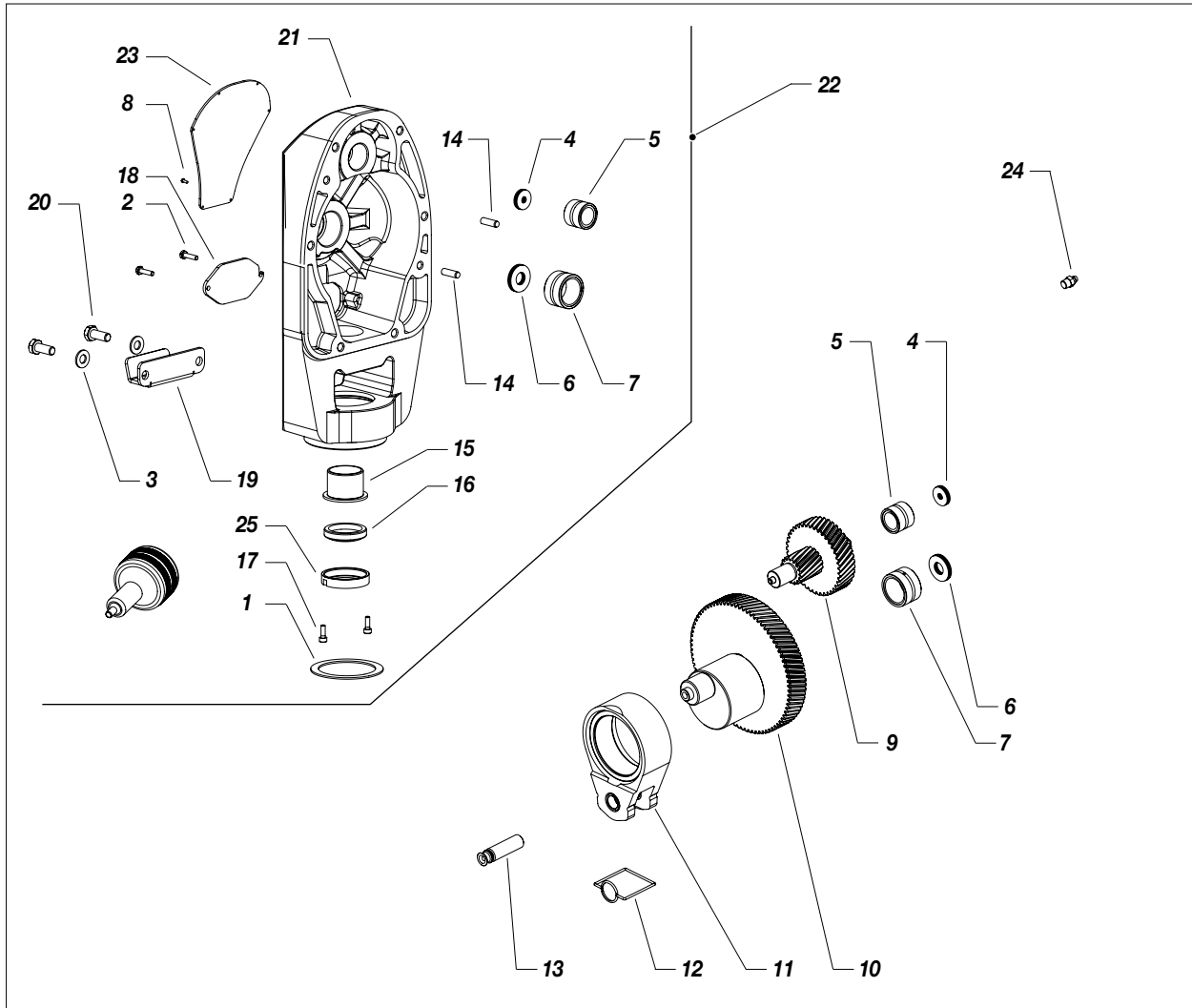

Pos.	Code	Description	Q.ty	Pos.	Code	Description	Q.ty
1	20285	O-Ring	1	14	20264	Centring pin	2
2	20245	Screw M4x10	2	15	20265	Guide bushing	1
3	34009	Washer	8	16	20266	Scraper	1
4	20250	Complete bearing	2	17	5378	Screw	2
5	20253	Bearing	2	18	20211	Inspection hatch	1
6	20254	Bearing	2	19	20212	Tin plate door	1
7	20257	Bearing	2	20	69011	Screw	2
8	34020	Rivet	6	21	20202	Reduction unit cover	1
9	20258	Toothed driving assembly	1	22	20267	Cover assembly	1
10	20259	Cam assembly	1	23	20215	Front sticker	1
11	20262	Complete connecting rod	1	24	20270	Greasing unit	1
12	20263	Positioning spring	1	25	20214	Fixing ring	1
13	20210	Pump unit pivot	1				

Y AT250 HIGH PRESSURE SPRAY GUN

WARNING: Contact the manufacturer always indicating code and quantity for each part required.

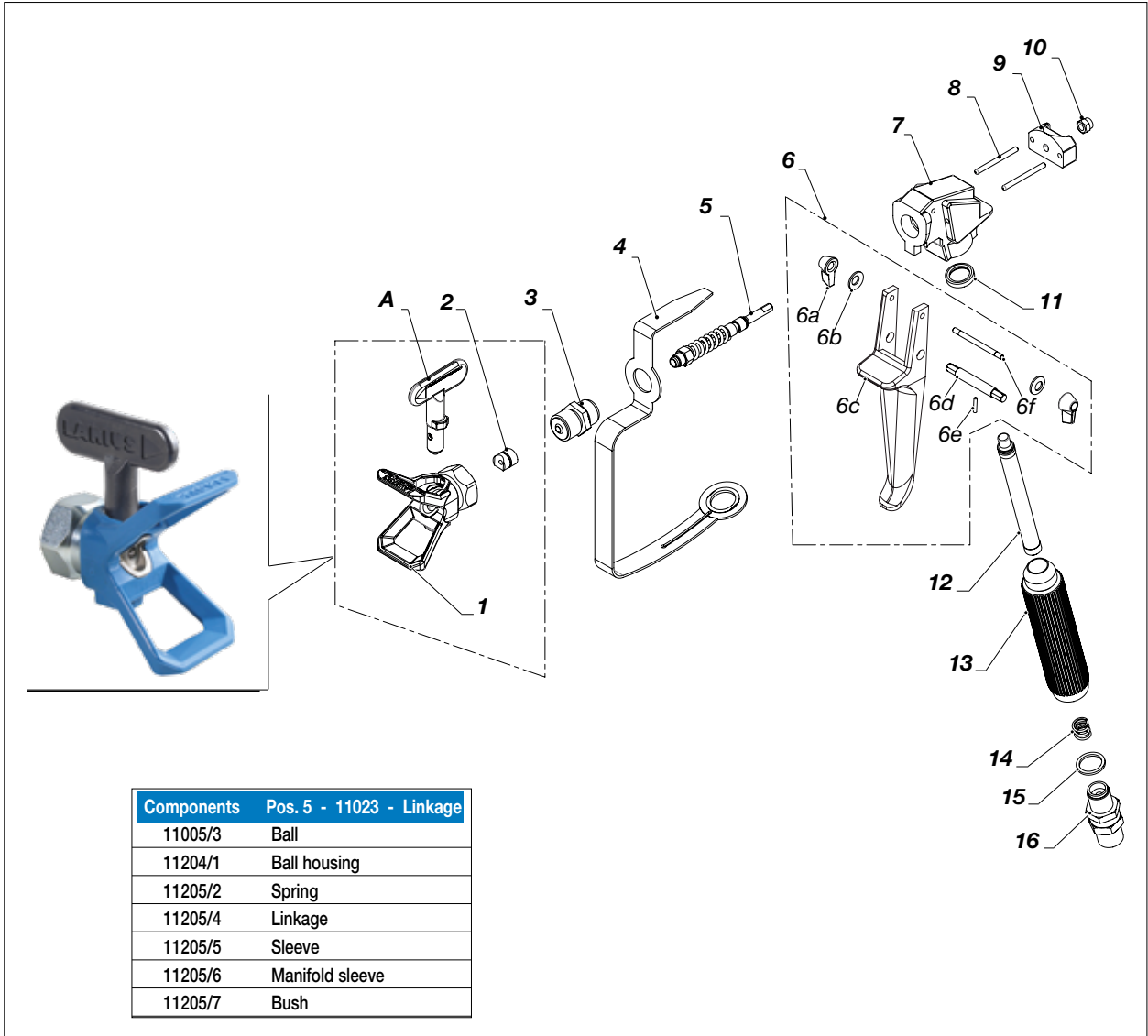

Pos.	Code	Description	Pos.	Code	Description
A	Veditab.*	Super Fast Clean nozzle	6f	11034	Pin
1	18270	Super Fast Clean body	7	11206	Spray gun body
2	18280	Super Fast Clean gasket	8	11207	Plug
3	11004	Sleeve	9	11208	Plate
4	11006 + 11032	Hand guard + 3 TSP 3x8 screws	10	11209	M5 self-locking nut
5	11203	Complete linkage rod	11	11020	Copper gasket
6	11008	Complete trigger	12	-	Filter
6a	11010	Safety lever	13	11018	Handgrip
6b	11011	Brake washer	14	11017	Spring
6c	11014	Trigger	15	32010	Copper gasket
6d	11012	Pin	16	11015	M16X1.5 articulated joint
6e	11013	Pin		11155	1/4" articulated joint

Z SPRAY GUN EXPLODED VIEW LA 95 LINER REF. 11700/4

WARNING: Contact the manufacturer always indicating code quantity for each part required.

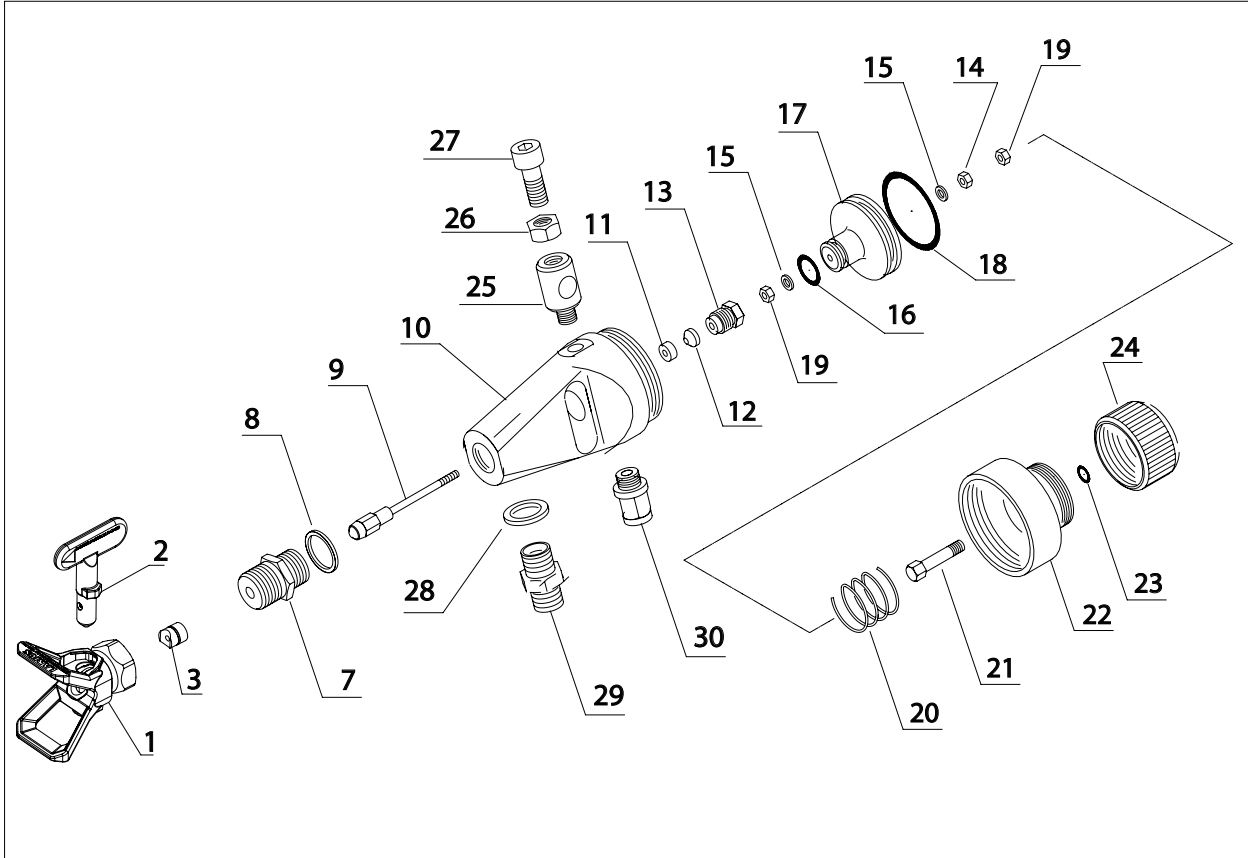

Pos.	Code	Description	Q.ty	Pos.	Code	Description	Q.ty
1	18270	Body Super Fast Clean	1	19	11027	Self-blocking nut	2
2	See table*	Nozzle Super Fast Clean	1	20	11108/1	Spring	1
3	18280	Gasket Super Fast Clean	1	21	11715	Screw	1
7	11004	Sleeve	1	22	11716	Back tap	1
8	33007	Washer	1	23	33013/7	O-ring	1
9	11705	Punch	1	24	11717	Adjusting knob	1
10	11711	Gun body	1	25	11718	Female coupling	1
11	11712	Gaskets stuffing ring	1		11720	Male coupling	1
12	11114	Gasket	1	26	52017	Nut	1
13	11713	Gaskets stuffing screw	1	27	34008	Screw	1
14	900025	M3 nut	1	28	33012	Washer	1
15	11714	Washer	2	29	3289	Nipple	1
16	32015/3	O-ring	1	30	11719	Cylindric fitting	1
17	11721	Piston	1				
18	11105	O-ring	1				

AA FLOW COMPENSATOR

WARNING: Contact the manufacturer always indicating code and quantity for each part required.

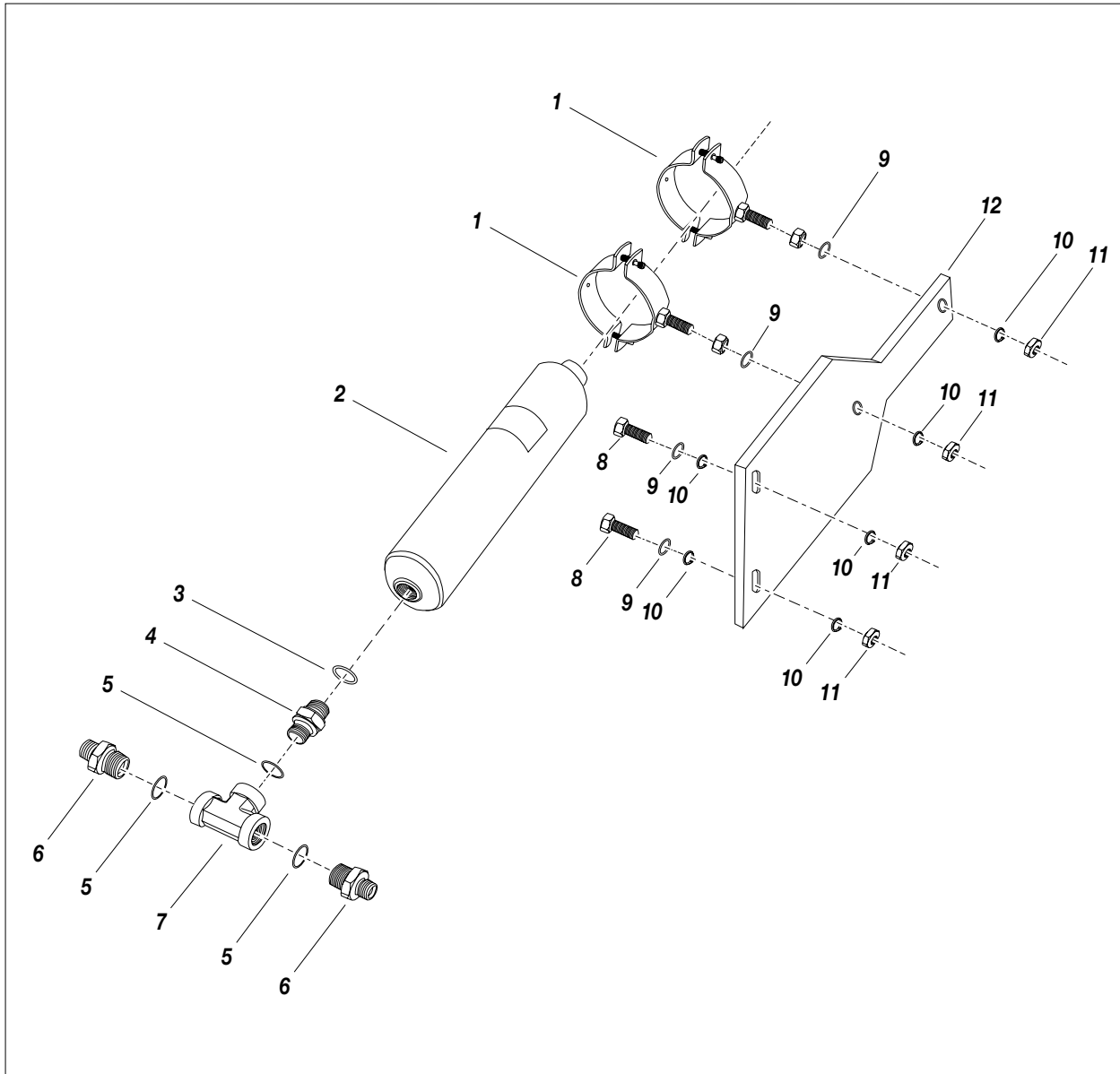

Pos.	Code	Description	Q.ty	Pos.	Code	Description	Q.ty
1	4522	Collar	2	7	8078/1	T fitting	1
2	4756	Flow compensator	1	8	20560	Screw	2
3	8071	Gasket	1	9	95096	Washer	4
4	3106	Union	1	10	81033	Washer (Typ Grower)	6
5	33010	Gasket	3	11	96080	Nut	4
6	34109	Union	2	12	4844	Bracket	1

AB BASIC HYDRAULIC BLOCK REF. 30400

WARNING: Contact the manufacturer always indicating code and quantity for each part required.

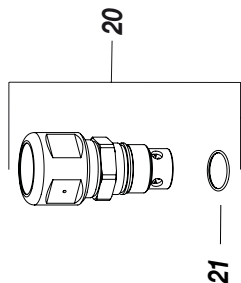

The Manufacturer declines all responsibility for any damage or malfunction of the machine following tampering or alteration of the valve calibration.

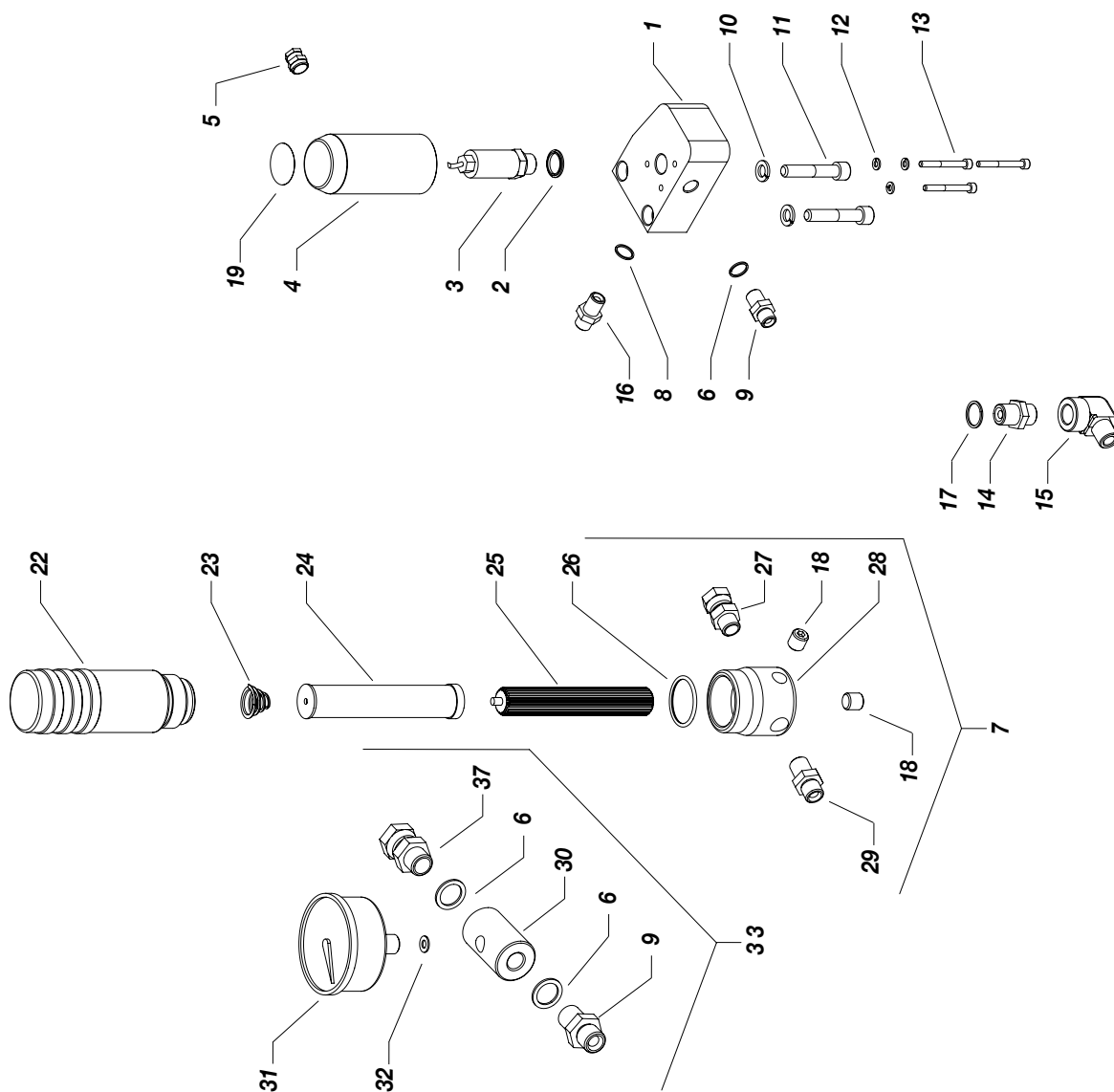

Pos.	Code	Description	Q.ty	Pos.	Code	Description	Q.ty
1	30401	Block base	1	18	96205	Dowel	2
2	20421	O-Ring	1	19	30439	Warning stickers	1
3	20457	Digital pressure switch	1	20	20423/0	Recirculation valve	1
4	20402	Protection	1	21	8402	Or	1
5	20450	Cable fastener	1	22	96201	Filter tank	1
6	3300	Washer	3	23	96202	Sieve spring	1
7	30469	Filter assembly	1	24	95218	Filter sieve	1
8	33010	Sealing washer	1	25	96207	Sieve holder	1
9	33006	Nipple	1	26	96203	Or	1
10	95114	Washer	2	27	37453	Nose union	2
11	30451	Screw	2	28	96204	Filter base	1
12	32005	Washer	3	29	96206	Nipple	1
13	20436	Screw	3	30	37452	Ball seat	1
14	96255	Union M-M	1	31	53011	Manometer	1
15	20451	Elbow M-F	1	32	37454	Gasket	1
16	34109	Union M-M	1	33	147	Complete pressure gauge	1
17	8071	Sealing washer	1				

AC THE BATTERY GROUP

WARNING: Contact the manufacturer always indicating code and quantity for each part required.

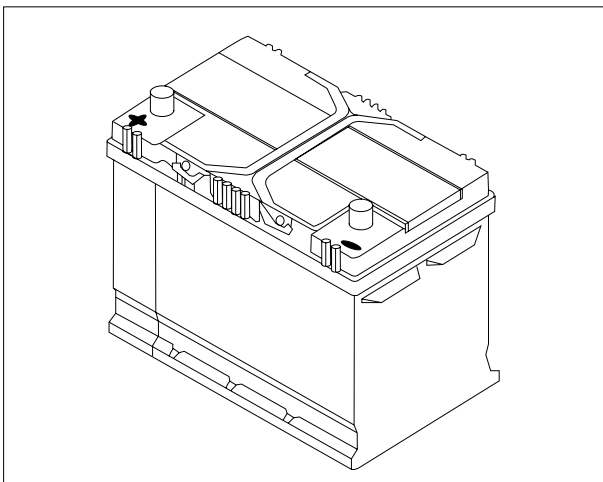

Code	Description
4010/1	Battery

AD 50L TANK

WARNING: Contact the manufacturer always indicating code and quantity for each part required.

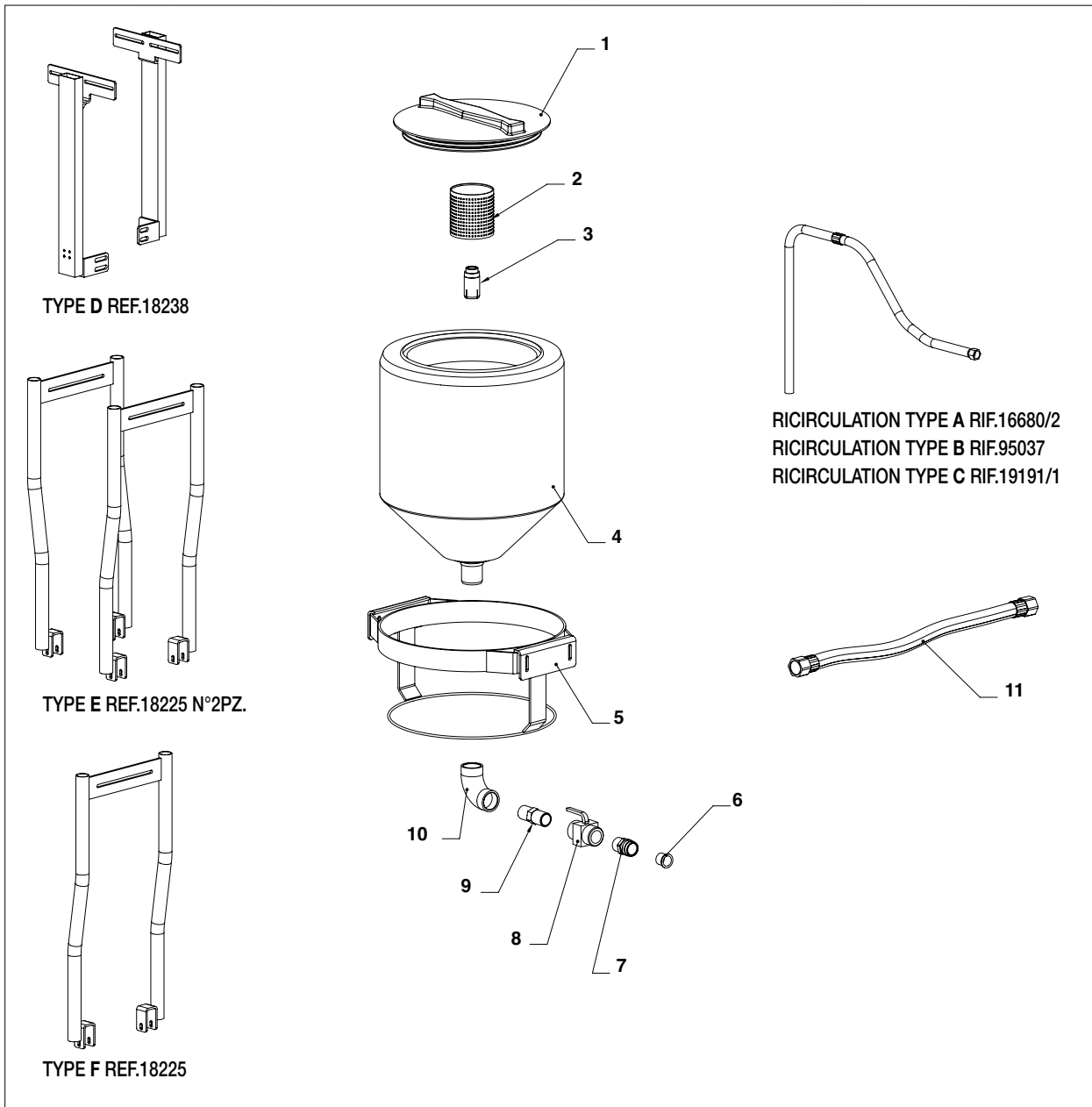

Pos.	Code	Description
1	18249/1	Cover
2	85014	Stainless stell fine drum filter
3	18231	Union
4	18249	Tank 50L
5	18246	Support
6	96099	Seal
7	95032	Union
8	30532	Tap
9	8375	Union
10	20833	Elbow connector
11	18223/1	Suction tube

Type Liner	Type	Type Ricirculation
LARIETTE LINER	Type E	Type A
3000 LINER	Type F	Type A
DALi LINER	Type D	Type A
DRAGON LINER	Type D	Type B
EVEREST	Type D	Type B
K2	Type D	Type C

AE BOARD V.2.50 - REF. 4996

WARNING: Contact the manufacturer always indicating code and quantity for each part required.



Code	Description	Q.ty
4996	Electronic board V.2.50	1

AF ACCESSORIES

WARNING: Contact the manufacturer always indicating code and quantity for each part required.



Art. 11220: AT 250 1/4+base
 Art. 11221: AT 250 M16x1,5+base



Code 96200:
 COMPLETE LINE FILTER



PISTON GUNSTOCK FILTERS
 Code 11039: Green (30M)
 Code 11038: White (60M)
 Code 11037: Yellow (100M)
 Code 11019: Red (200M)



Code 95218: FILTER 30 MESH
 Code 95219: FILTER 60 MESH
 Code 95220: FILTER 100 MESH
 Code 95221: FILTER 200 MESH



Art. 147: HIGH PRESSURE MANOMETER
 M16x1,5
 Art. 150: HIGH PRESSURE MANOMETER
 GJ 1/4"



Code 16685:
 SUCTION DISPERSION
 SYSTEM

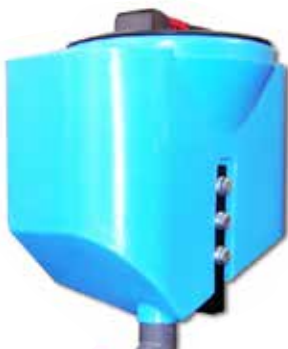

Code 4405:
 PEARLIZED REFLECTING PAINT DISTRIBUTION KIT

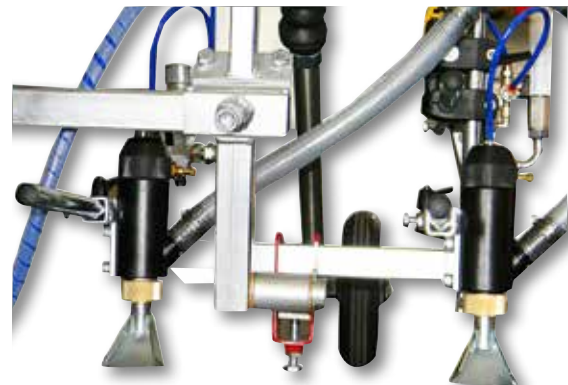

Code 4500:
 PEARLIZED REFLECTING PAINT DISTRIBUTION



Art. 4038: LASER POINTER



ELECTRIC MIXERS:

Art. 217550: MX 850 Power 850W

Art. 217560: MX 1100 Power 1080W

Art. 217570: MX 1100E Power 1080W



Art. 4506: ADJUSTABLE SPOTLIGHT



Art. 4507: FLASHING LIGHT

Art. 26000: OPERATOR FOOTBOARD



Art. 4720: SEAT KIT

TOP-SPRAYING CLEAN

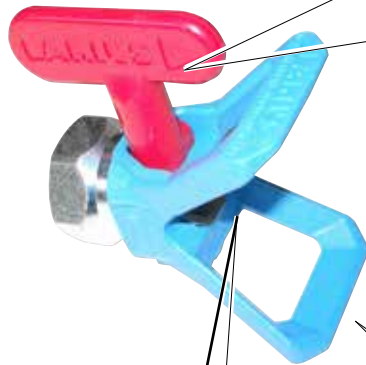

Nozzle code	
TSC 7-20	TSC 19-20
TSC 7-40	TSC 19-40
TSC 9-20	TSC 19-60
TSC 9-40	TSC 21-20
TSC 11-20	TSC 21-40
TSC 11-40	TSC 21-60
TSC 13-20	TSC 23-20
TSC 13-40	TSC 23-40
TSC 13-60	TSC 23-60
TSC 15-20	TSC 27-20
TSC 15-40	TSC 27-40
TSC 15-60	TSC 27-60
TSC 17-20	TSC 31-40
TSC 17-40	TSC 31-60
TSC 17-60	

UGELLO TOP-SPRAYING CLEAN



Art. 18280: GASKET



Art. 18270: SUPER FAST-CLEAN
base UE 11/16x16

SUPER FAST-CLEAN



Nozzle code		
SFC07-20	SFC19-60	SFC29-80
SFC07-40	SFC21-20	SFC31-40
SFC09-20	SFC21-40	SFC31-60
SFC09-40	SFC21-60	SFC31-80
SFC11-20	SFC23-20	SFC33-40
SFC11-40	SFC23-40	SFC33-60
SFC13-20	SFC23-60	SFC33-80
SFC13-40	SFC25-20	SFC39-40
SFC13-60	SFC25-40	SFC39-60
SFC15-20	SFC25-60	SFC39-80
SFC15-40	SFC27-20	SFC43-40
SFC15-60	SFC27-40	SFC43-60
SFC17-20	SFC27-60	SFC43-80
SFC17-40	SFC27-80	SFC51-40
SFC17-60	SFC29-20	SFC51-60
SFC19-20	SFC29-40	SFC51-80
SFC19-40	SFC29-60	

NOZZLE SUPER FAST-CLEAN



Art. 18280: GASKET



Art. 18270: SUPER FAST-CLEAN base UE 11/16x16

GUN EXTENSION

- Art. 153: cm 30
- Art. 153: cm 40
- Art. 155: cm 60
- Art. 158: cm 80
- Art. 156: cm 100



PLA 1/4" + FAST
SUPER FAST-CLEAN TIP INCLUDED
Art. K11420-K11425-K11430:
cm 130-180-240

PLA M16x1,5 + SUPER FAST-CLEAN
TIP INCLUDED
Art. K11421-K11426-K11431:
cm 130-180-240



Art. 16780:
TELESCOPIC PAINT ROLLER

- complete with:
- n. 1 Roller with extra-long fiber
 - n. 1 Roller with long fiber
 - n. 1 Roller with medium fiber

Flexible hose mt. 2 3/16 " M16x1,5



TUBES MANUAL WINDER
3/16" - 3/8" - 1/4" max lenght mt. 20



HIGH PRESSURE HOSE
Ø 3/16 - 1/4 - 3/8

Intentionally blank page



CE DECLARATION OF CONFORMITY



Company



LARIUS srl
Via Antonio Stoppani 21 - 23801 Calolziocorte (LC) ITALY
Tel: +39 0341 621152
Fax: +39 0341 621243
E-mail: larius@larius.com

Declares under his owns responsibility that the product:

Everest TH Liner Horizontal Street Marking

complies with the directives:

- EC Directive 2006/42 Machinery Directive
- EU Directive 2014/30 Electromagnetic Compatibility (EMC)
- EU Directive 2014/35 Low Voltage (LVD)

furthermore to the
harmonized standards:

- UNI EN ISO 12100-1/-2
Machinery safety, basic concepts, general principles of design. Basic terminology, methodology. Technical principles.

This declaration relates exclusively to the product in the state in which it was placed on the market, and excludes components or modifications which are added or carried out subsequently by end user.

Signature

Pierangelo Castagna
Managing Director

Calolziocorte, 12 February 2024
Location / Date



**SAMOA INDUSTRIAL, S.A. - HEADQUARTERS
SPAIN AND EXPORT MARKETS**

POL. IND. PORCEYO, I-14 - CAMINO DEL FONTÁN, 831
E-33392 GIJÓN (ASTURIAS), SPAIN
TEL.: +34 985 381 488 - FAX: + 34 985 147 213

**SAMOA S.A.R.L.
FRANCE**

P.A.E.I. DU GIESSEN
3, RUE DE BRISCHBACH
67750 SCHERWILLER, FRANCE
TEL.: +33 3 88 82 79 62 - FAX: +33 3 88 82 77 88

**SAMOA ITALIA - LARIUS
ITALY**

VIA ANTONIO STOPPANI,21
23801 CALOLZIOCORTE (LC) ITALY
Tel.: +39 0341 621152 - Fax: + 39 0341 621242

SAMOA FLOWTECH GMBH

GERMANY, AUSTRIA, SWITZERLAND, THE NETHERLANDS AND GREECE
AM OBEREICHHOLZ 4
D - 97828 MARKTHEIDENFELD, GERMANY
TEL.: +49 9391 9826 0 - FAX: +49 9391 98 26 50

SAMOA LTD.

UNITED KINGDOM AND REP. OF IRELAND

ASTURIAS HOUSE - BARRS FOLD ROAD
WINGATES INDUSTRIAL PARK
WESTHOUGHTON, BL5 3XP, UK
TEL.: +44 1942 850600 - FAX: +44 1942 812160

SAMOA CORPORATION

USA AND CANADA
90 MONTICELLO ROAD
WEAVERVILLE, NC 28787, USA
TEL. +1 (828) 645-2290 - FAX: +1 (828) 658 0840



©Copyright, SAMOA INDUSTRIAL, S.A.
SAMOA Industrial, S.A. is an ISO 9001, ISO 14001 and ISO 45001 certified company.

»» Contact us today!

Visit www.samoaindustrial.com for more information.

OPERATING AND MAINTENAINCE MANUAL AVAILABLE IN:		
	IT	https://www.larius.com/wp-content/uploads/EVERESTLINER_I.pdf
	EN	https://www.larius.com/wp-content/uploads/EVERESTLINER_GB.pdf
	DE	https://www.larius.com/wp-content/uploads/EVERESTLINER_D.pdf
	FR	https://www.larius.com/wp-content/uploads/EVERESTLINER_D.pdf
	ES	https://www.larius.com/wp-content/uploads/EVERESTLINER_SP.pdf
	PL	https://www.larius.com/wp-content/uploads/EVERESTLINER_PL.pdf