



www.larius.com

DALI'

Electric diaphragm pump



IT	https://www.larius.com/wp-content/uploads/DALI_I.pdf
EN	https://www.larius.com/wp-content/uploads/DALI_UK.pdf
DE	https://www.larius.com/wp-content/uploads/DALI_D.pdf
FR	https://www.larius.com/wp-content/uploads/DALI_F.pdf
ES	https://www.larius.com/wp-content/uploads/DALI_SP.pdf
RU	https://www.larius.com/wp-content/uploads/DALI_RU-1.pdf
PL	https://www.larius.com/wp-content/uploads/DALI_PL.pdf
PT	https://www.larius.com/wp-content/uploads/DALI_P.pdf

LAK 18957/1	DALÍ motor 220V + gun
LA 18900/1	DALÍ motor 220V
LAK 18958/1	DALÍ motor 110V + gun
LA 18920/1	DALÍ motor 110V

**This manual is to be considered as an English language translation of the original manual in Italian.
The manufacturer shall bear no responsibility for any damages or inconveniences that may arise due to
the incorrect translation of the instructions contained within the original manual in Italian.**

**Due to a constant product improvement programme, the factory reserves the right to modify
technical details mentioned in this manual without prior notice.**

DALI'

Electric diaphragm pump

INDEX



















A	WARNING.....	4
B	TRANSPORT AND UNPACKING.....	5
C	CONDITIONS OF GUARANTEE.....	5
D	SAFETY RULES.....	5
E	WORKING PRINCIPLE.....	7
F	TECHNICAL DATA.....	7
G	DESCRIPTION OF THE EQUIPMENT.....	8
H	SETTING-UP.....	9
I	WORKING.....	11
J	CLEANING AT THE END WORK.....	12
K	ROUTINE MAINTENANCE.....	13
L	WARNING PLATE.....	14
M	CORRECT PROCEDURE OF DECOMPRESSION.....	15
N	PROBLEMS AND SOLUTIONS.....	16
SPARE PART		
O	COMPLETE HYDRAULIC BODY.....	18
P	PETROL ENGINE.....	20
Q	COMPLETE COLOUR BODY.....	22
R	SUCTION SYSTEM.....	25
S	TROLLEY.....	26
	DECLARATION OF CONFORMITY.....	29

**WE ADVISE THE USE OF THIS EQUIPMENT ONLY BY PROFESSIONAL OPERATORS.
 ONLY USE THIS MACHINE FOR USAGE SPECIFICALLY MENTIONED IN THIS MANUAL.**

Thank you for choosing a **SAMOA** product.
 As well as the product purchased, you will receive a range of support services
 enabling you to achieve the results desired, quickly and professionally.

A WARNINGS

The table below provides the meaning of the symbols used in this manual in relation to using, earthing, operating, maintaining, and repairing of this equipment.

	<ul style="list-style-type: none"> • Read this operator's manual carefully before using the equipment. • An improper use of this machine can cause injuries to people or things. • Do not use this machine when under the influence of drugs or alcohol. • Do not modify the equipment under any circumstances. • Use products and solvents that are compatible with the various parts of the equipment, and read the manufacturer's warnings carefully. • See the Technical Details for the equipment given in the Manual. • Check the equipment for worn parts once a day. If any worn parts are found, replace them using ONLY original spare parts. • Keep children and animals away from work area. • Comply with all safety standards.
	<ul style="list-style-type: none"> • It indicates an accident risk or serious damage to equipment if this warning is not followed.
   	<p>FIRE AND EXPLOSION HAZARD</p> <ul style="list-style-type: none"> • Solvent and paint fumes in work area can ignite or explode. • To help prevent fire and explosion: <ul style="list-style-type: none"> - Use equipment ONLY in well ventilated area. - Eliminate all ignition sources, such as pilot lights, cigarettes and plastic drop cloths (potential static arc). - Ground equipment and conductive objects. - Use only grounded hoses. • Do not use trichloroethane, methylene chloride, other halogenated hydrocarbon solvents or fluids containing such solvents in pressurized aluminium equipment. Such use can cause serious chemical reaction and equipment rupture, and result in death, serious injury, and property damage. • Do not form connections or switch light switches on or off if the air contains inflammable fumes. • If electrical shocks or discharges are encountered the operation being carried out using the equipment must be stopped immediately. • Keep a fire extinguisher at hand in the immediate vicinity of the work area.
	<ul style="list-style-type: none"> • It indicates wound and finger squashing risk due to movable parts in the equipment. • Tenersi lontano dalle parti in movimento. • Do not use the equipment without the proper protection. • Before any inspection or maintenance of the equipment, carry out the decompression procedure explained in this manual, and prevent any risk of the equipment starting unexpectedly.
 	<ul style="list-style-type: none"> • Report any risk of chemical reaction or explosion if this warning has not been given. • (IF PROVIDED) There is a risk of injury or serious lesion related to contact with the jet from the spray gun. If this should occur, IMMEDIATELY contact a doctor, indicating the type of product injected. • (IF PROVIDED) Do not spray before the guard has been placed over the nozzle and the trigger on the spray gun. • (IF PROVIDED) Do not put your fingers in the spray gun nozzle. • Once work has been completed, before carrying out any maintenance, complete the decompression procedure.
	<ul style="list-style-type: none"> • It indicates important recommendations about disposal and recycling process of products in accordance with the environmental regulations.
    	<ul style="list-style-type: none"> • Mark any clamps attached to earth cables. • Use ONLY 3-wire extension cords and grounded electrical outlets. • Before starting work make sure that the electrical system is grounded and that it complies with safety standards. • High-pressure fluid from gun, hose leaks, or ruptured components will pierce skin. • To help prevent injection, always: <ul style="list-style-type: none"> - (IF PROVIDED) Engage trigger lock when not spraying. - (IF PROVIDED) Do not put your hand over the spray tip. Do not stop or deflect leaks with your hand, body or other. - (IF PROVIDED) Do not point gun at anyone or at any part of the body. - (IF PROVIDED) Never spray without tip guard. - Do pressure relief if you stop spraying or being servicing sprayer and before any maintenance operations. - Do not use components rated less than sprayer Maximum Working Pressure. - Never allow children to use this unit - (IF PROVIDED) Brace yourself; gun may recoil when triggered. <p>If high pressure fluid pierces your skin, the injury might look like "just a cut", but it is a serious wound! Get immediate medical attention.</p>
   	<ul style="list-style-type: none"> • It is obligatory to wear suitable clothing as gloves, goggles and face shield. • Wear clothing that complies with the safety standards in force in the country in which the equipment is used. • Do not wear bracelets, earrings, rings, chains, or anything else that may hinder the operator's work. • Do not wear clothing with wide sleeves, scarves, ties, or any other piece of clothing that could get tangled up in moving parts of the equipment during the work, inspection, or maintenance cycles.

B TRANSPORT AND UNPACKING

- The packed parts should be handled as indicated in the symbols and markings on the outside of the packing.
- Before installing the equipment, ensure that the area to be used is large enough for such purposes, is properly lit and has a clean, smooth floor surface.
- The user is responsible for the operations of unloading and handling and should use the maximum care so as not to damage the individual parts or injure anyone.

To perform the unloading operation, use only qualified and trained personnel (truck and crane operators, etc.) and also suitable hoisting equipment for the weight of the installation or its parts.

Follow carefully all the safety rules.

The personnel must be equipped with the necessary safety clothing.

- The manufacturer will not be responsible for the unloading operations and transport to the workplace of the machine.
- Check the packing is undamaged on receipt of the equipment. Unpack the machine and verify if there has been any damage due to transportation.

In case of damage, call immediately **the manufacturer** and the Shipping Agent. All the notices about possible damage or anomalies must arrive timely within 8 days at least from the date of receipt of the plant through Registered Letter to the Shipping Agent and to the manufacturer.

- The disposal of packaging materials is a customer's competence and must be performed in accordance with the regulations in force in the country where the plant is installed and used. It is nevertheless sound practice to recycle packaging materials in an environment-friendly manner as much as possible.

C CONDITIONS OF GUARANTEE

The conditions of guarantee do not apply in the following situations:

- improper washing and cleaning of components causing malfunction, wear or damage to the equipment or any of its parts;
- improper use of the equipment;
- use that does not conform with applicable national legislation;
- incorrect or faulty installation;
- modifications, interventions and maintenance that have not been authorised by the manufacturer;
- use of non-original spare parts or parts that do not correspond to the specific model;
- total or partial non-compliance with the instructions provided.



D SAFETY RULES

- THE EMPLOYER SHALL TRAIN ITS EMPLOYEES ABOUT ALL THOSE RISKS STEMMING FROM ACCIDENTS, ABOUT THE USE OF SAFETY DEVICES FOR THEIR OWN SAFETY AND ABOUT THE GENERAL RULES FOR ACCIDENT PREVENTION IN COMPLIANCE WITH INTERNATIONAL REGULATIONS AND WITH THE LAWS OF THE COUNTRY WHERE THE PLANT IS USED.
- THE BEHAVIOUR OF THE EMPLOYEES SHALL STRICTLY COMPLY WITH THE ACCIDENT PREVENTION AND ALSO ENVIRONMENTAL REGULATIONS IN FORCE IN THE COUNTRY WHERE THE PLANT IS INSTALLED AND USED.



Read carefully and entirely the following instructions before using the product. Please save these instructions in a safe place.

The unauthorised tampering/replacement of one or more parts composing the machine, the use of accessories, tools, expendable materials other than those recommended by the Manufacturer can be a danger of accident.

The Manufacturer will be relieved from tort and criminal liability.

- KEEP YOUR WORK PLACE CLEAN AND TIDY. DISORDER WHERE YOU ARE WORKING CREATES A POTENTIAL RISK OF ACCIDENTS.
- ALWAYS KEEP PROPER BALANCE AVOIDING UNUSUAL STANCE.
- BEFORE USING THE TOOL, ENSURE THERE ARE NOT DAMAGED PARTS AND THE MACHINE CAN WORK PROPERLY.
- ALWAYS FOLLOW THE INSTRUCTIONS ABOUT SAFETY AND THE REGULATIONS IN FORCE.
- KEEP THOSE WHO ARE NOT RESPONSIBLE FOR THE EQUIPMENT OUT OF THE WORK AREA.
- **NEVER** EXCEED THE MAXIMUM WORKING PRESSURE INDICATED.
- **NEVER** POINT THE SPRAY GUN AT YOURSELVES OR AT OTHER PEOPLE. THE CONTACT WITH THE CASTING CAN CAUSE SERIOUS INJURIES.
- IN CASE OF INJURIES CAUSED BY THE GUN CASTING, SEEK IMMEDIATE MEDICAL ADVICE SPECIFYING THE TYPE OF THE PRODUCT INJECTED. **NEVER** UNDERVALUE A WOUND CAUSED BY THE INJECTION OF A FLUID.
- ALWAYS DISCONNECT THE SUPPLY AND RELEASE THE PRESSURE IN THE CIRCUIT BEFORE PERFORMING ANY CHECK OR PART REPLACEMENT OF THE EQUIPMENT.

- NEVER MODIFY ANY PART IN THE EQUIPMENT. CHECK REGULARLY THE COMPONENTS OF THE SYSTEM. REPLACE THE PARTS DAMAGED OR WORN.
- TIGHTEN AND CHECK ALL THE FITTINGS FOR CONNECTION BETWEEN PUMP, FLEXIBLE HOSE AND SPRAY GUN BEFORE USING THE EQUIPMENT.
- ALWAYS USE THE FLEXIBLE HOSE SUPPLIED WITH STANDARD KIT.
- THE USE OF ANY ACCESSORIES OR TOOLING OTHER THAN THOSE RECOMMENDED IN THIS MANUAL, MAY CAUSE DAMAGE OR INJURE THE OPERATOR.
- THE FLUID CONTAINED IN THE FLEXIBLE HOSE CAN BE VERY DANGEROUS. HANDLE THE FLEXIBLE HOSE CAREFULLY. DO NOT PULL THE FLEXIBLE HOSE TO MOVE THE EQUIPMENT. NEVER USE A DAMAGED OR A REPAIRED FLEXIBLE HOSE.
- NEVER SPRAY OVER FLAMMABLE PRODUCTS OR SOLVENTS IN CLOSED PLACES.
- NEVER USE THE TOOLING IN PRESENCE OF POTENTIALLY EXPLOSIVE GAS.



The high speed of travel of the product in the hose can create static electricity through discharges and sparks. It is suggested to earth the equipment.

The pump is earthed through the earth cable of the supply. The gun is earthed through the high pressure flexible hose. All the conductors near the work area must be earthed.



Always check the product is compatible with the materials composing the equipment (*pump, spray gun, flexible hose and accessories*) with which it can come into contact. Never use paints or solvents containing Halogen Hydrocarbons (as the *Methylene Chloride*).

If these products come into contact with aluminium parts can provoke dangerous chemical reactions with risk of corrosion and explosion.



Take proper safety measures for the protection of hearing in case of work near the plant.



If the product to be used is toxic, avoid inhalation and contact by using protection gloves, goggles and proper face shields.

ELECTRICAL SAFETY PRECAUTIONS

- Check the "ON/OFF" switch is on the "OFF" position before connecting the cable to the mains.
- Never carry a plugged-in equipment.
- Disconnect the equipment before storing it and before performing any maintenance operation or replacing of accessories.
- Do not carry the equipment neither unplug it by pulling the electric cable.
Protect the cable from heat, oil and sharp edges.
- When the tool is used outdoors, use only an extension cable suited for outdoor use and so marked.



Never attempt to tamper with the calibre of instruments.

- Take care when the pumping rod is moving.
Stop the machine whenever someone is within its vicinity.
- Repairs of the electrical equipment should only be carried out by skilled personnel, otherwise considerable danger to the user may result.

E WORKING PRINCIPLE

The DALÍ unit is defined as an “electric diaphragm pump”. An electric diaphragm pump is used for high pressure paint spraying without air (*known as “airless”*).

The pump is powered by an electric (internal combustion) motor coupled with a cam shaft. The shaft acts on the hydraulic piston as it pumps oil from the hydraulic case and sends the suction diaphragm into fibrillation. When the diaphragm moves, it cre-

ates a vacuum. The product is sucked up, pushed towards the pump outlet and sent to the guns through the flexible hose . A hydraulic valve on the hydraulic case head allows setting and checking the pressure of the paint product at the pump outlet. A second hydraulic safety valve to avoid over-pressure, ensures total equipment reliability.

F TECHNICAL DATA

	DALI'
Version	Trolley
Max. delivery	4 l/m
Max. working pressure	220 bar
Motor power	1,1 Kw
Voltage	110 VAC (60Hz)
	220 VAC (50Hz)
	380 VAC (50Hz)
Weight	38 Kg
Max. nozzle size	0,027"
Power generation	3 Kw single phase
Material outlet	1/4" (M)
Livello pressione sonora	≤ 65dB (A)
Length (A)	1100 mm
Width (B)	500 mm
Height (C)	min. 710 mm
	max. 1000 mm

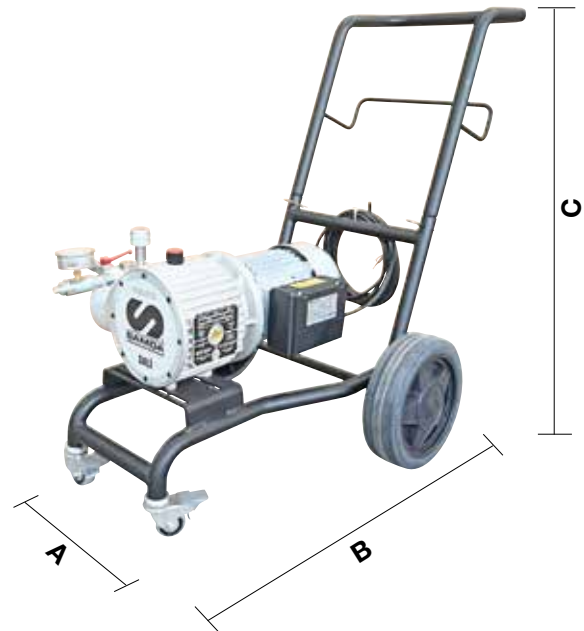

Fig. 1

PARTS OF THE PUMP IN CONTACT WITH THE MATERIAL: Stainless Steel AISI 420B, PTFE, Aluminium.

	COD.	MOTOR	FITTING	HOSE	GUN
SUCTION SYSTEM	K18957/1	220 V	1/4"	Cod. 18023	Cod. 11250
	18900/1	220 V	1/4"	-	-
	K18958/1	110 V	1/4"	Cod. 18023	Cod. 11250
	18920/1	110 V	1/4"	-	-
	K18959/1	380 V	1/4"	Cod. 18023	Cod. 11250
	18955/1	380 V	1/4"	-	-
50 L. TANK	K18945/1	220 V	1/4"	Cod. 18023	Cod. 11250
	18945/1	220 V	1/4"	-	-

G DESCRIPTION OF THE EQUIPMENT

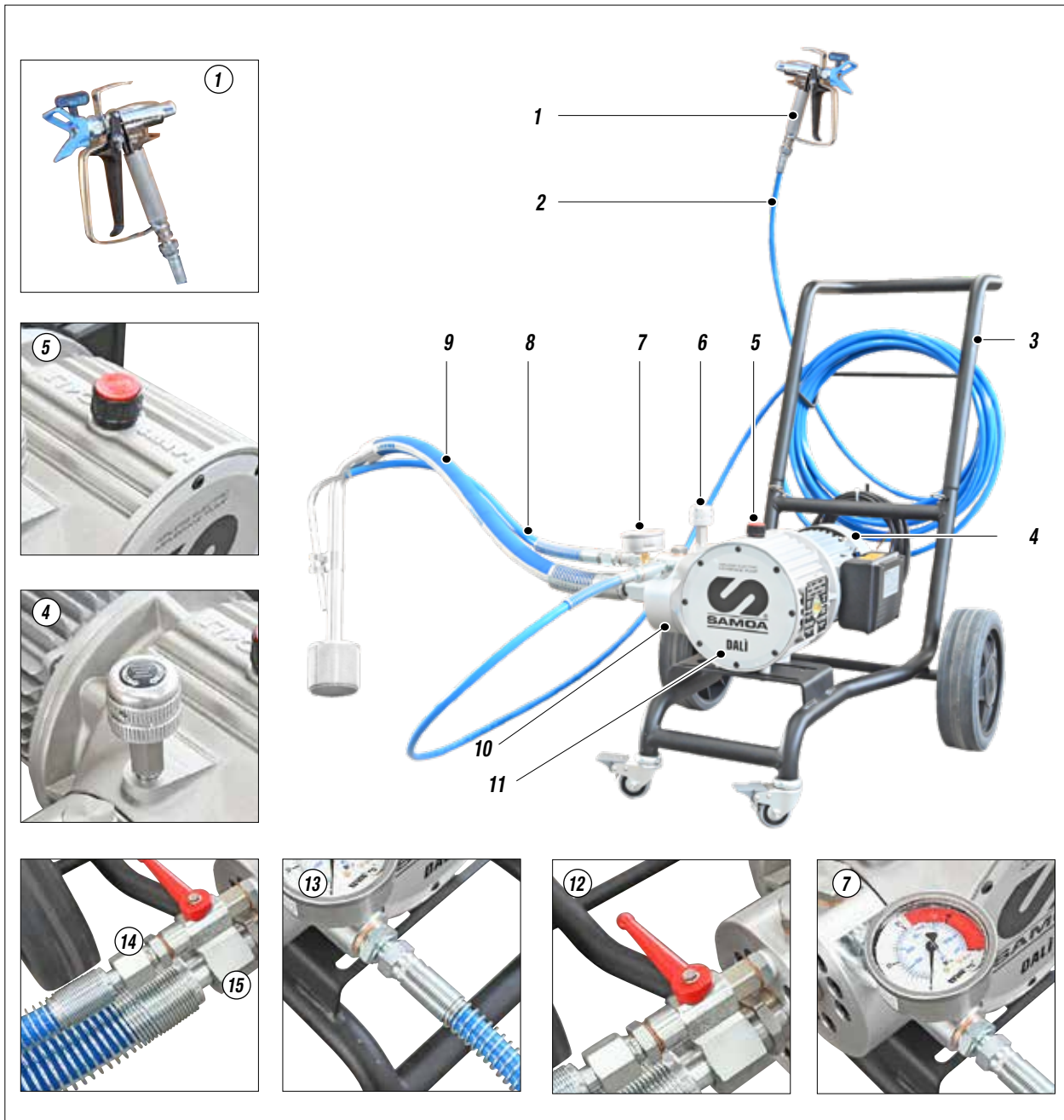

Fig. 1

Pos.	Description
1	LARIUS AT 250 gun
2	High pressure feed tube
3	Carriage
4	Electric / combustion motor
5	Hydraulic oil filling cap
6	Setting valve
7	Manometer
8	Recirculation tube

Pos.	Description
9	Suction tube
10	Colour body
11	Hydraulic body
12	Recirculation valve
13	Feed tube connection
14	Recirculation pipe connection
15	Product suction tube connection

H SETTING-UP

HOSE AND GUN CONNECTIONS

- Connect the high pressure flexible hose to the pump and to the gun, ensuring to tighten the fittings (*the use of two wrenches is suggested*).
- It is recommended to use the hose provided with the standard kit (*ref. 35017*).



NEVER use sealants on fittings' threads.
NEVER use a damaged or a repaired flexible hose.

ELECTRIC POWER SUPPLY CONNECTIONS

- Check the plant is earthed.

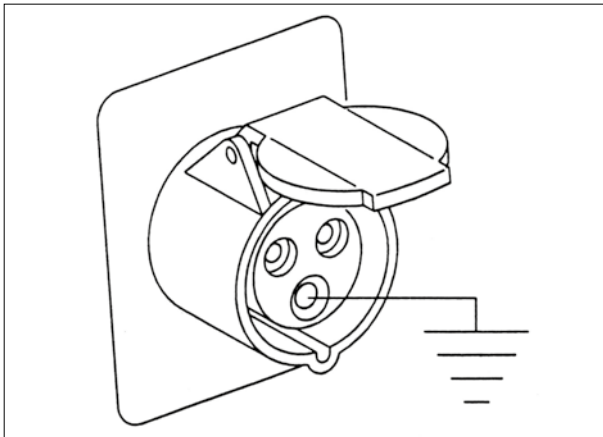

Fig. 1

- Check the mains voltage corresponds to the equipment's rating (1).



Fig. 2

- The supply cable (2) is provided without plug. Use a plug which guarantees the plant earthing. Only a technician or a skilled person should perform the connection of the plug to the electric cable.



Fig. 3

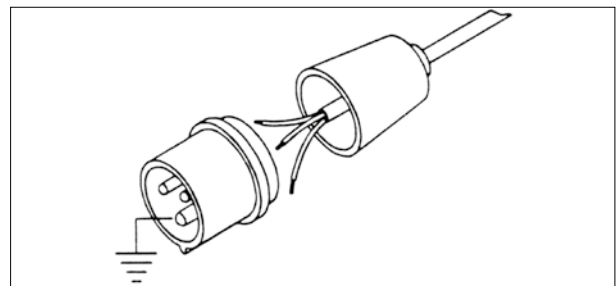

Fig. 4



Should anyone use an extension cable between the tooling and the socket, it must have the same characteristics as the cable supplied (*minimum diameter of the wire 2.5 mm²*) with a maximum length of 50 mt. Higher lengths and lower diameters can provoke excessive voltage falls and also an anomalous working of the equipment.

CONNECTION OF THE TOOLING TO THE POWER SUPPLY

- Check the ON/OFF switch (3) is on the "OFF" position before connecting the cable to the mains.
- Place the pressure control knob (4) on the "MIN" position (*turn counterclockwise*).



Fig. 5

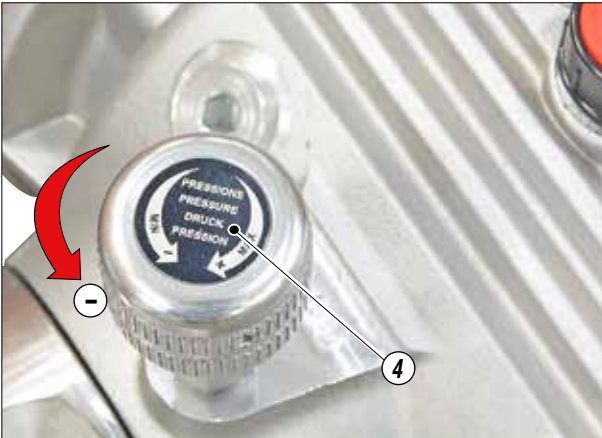

Fig. 6

WASHING OF THE NEW EQUIPMENT

- The equipment has already been adjusted at our factory with light mineral oil left inside the pumping group as protection. Therefore, wash with diluent before sucking the product.
- Lift the suction pipe and dip it into the solvent tank (5).
- Ensure the gun (6) is without nozzle.
- Open the re-circulation tap (7). Turn the unit ON-OFF switch (H8) on the "ON" position.

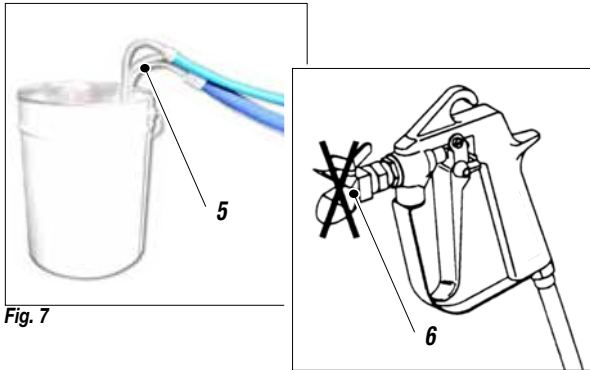

Fig. 7

- Rotate the pressure setting knob (4) slightly clockwise so that the machine operates at minimum power.

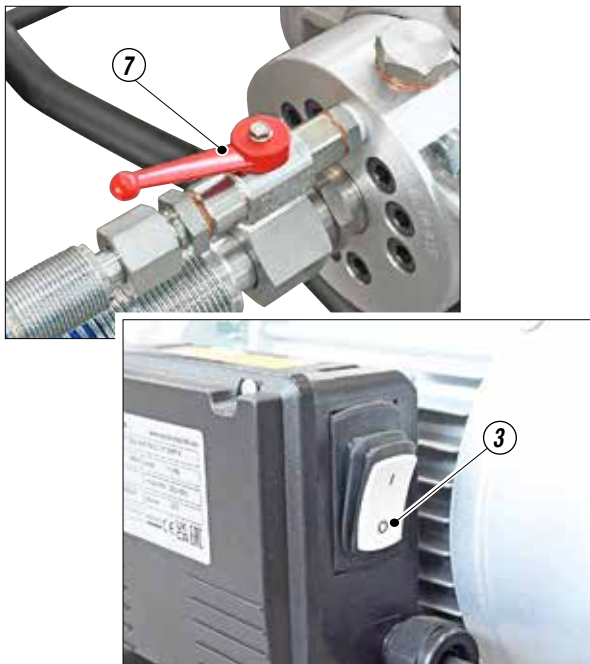

Fig. 8

- Point the gun at a container keeping the trigger pressed (so as to drain the oil inside) till a clean solvent comes out. Now,



Fig. 9

- release the trigger.
- Remove the suction pipe and take away the solvent tank.
- Point the gun at the solvent tank and press the trigger so as to recover the residual solvent.
- As the pump idles, press the ON/OFF switch (3) on the position "OFF" to stop the tooling.



Absolutely avoid to spray solvents indoors. In addition, it is recommended to keep away from the pump in order to avoid the contact between the solvent fumes and the electric motor.

- Now the machine is ready. Should you use water paints, besides the solvent wash, a wash with soapy and then clean water is suggested.
- Insert the gun trigger lock and assemble the nozzle.

PREPARATION OF THE PAINT

- Make sure the product is suitable to be used with a spray gun.
- Mix and filter the product before using it. For filtration, use **CLOSE-MESH** (ref.214) and **LARGE-MESH** (ref.215) **LARIUS METEX** braids.



Make sure the product to be used is compatible with the materials employed for manufacturing the equipment (stainless steel and aluminium). Because of that, please contact the supplier of the product.

Never use products containing halogen hydrocarbons (as *methylene chloride*). If these products come into contact with aluminium parts of the equipment, can provoke dangerous chemical reactions with risk of explosion.

I WORKING

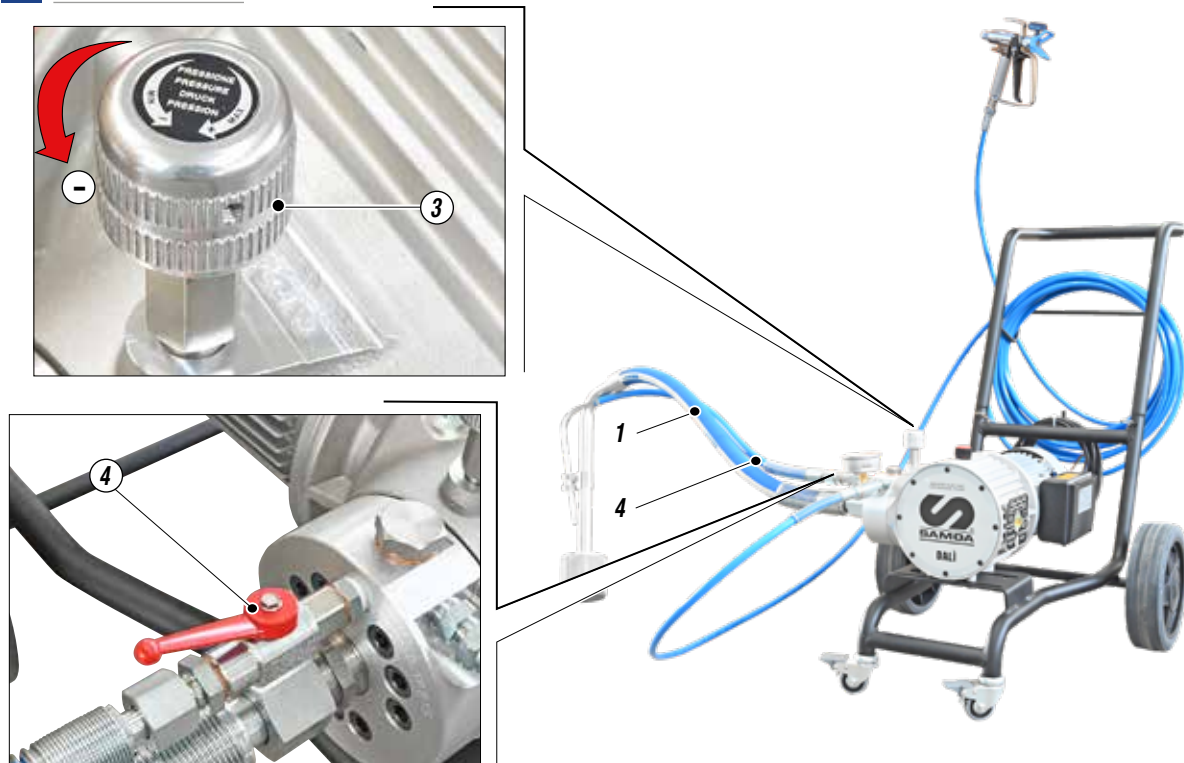

Fig. 1

START OF THE PAINTING OPERATIONS

- Use the tooling after performing all the **SETTING UP** operations above described.
- Dip the suction pipe (1) into the product tank.
- Open the re-circulation valve (2).
- Press the **ON/OFF** switch of the equipment and turn a little the pressure control knob (3), so as the machine works at the idle speed.
- Make sure the product recycles from the return tube (4).
- Close the re-circulation valve.
- At this point the machine will continue to suck the paint product until the delivery hose is completely full. Afterwards, the product will re-circulate automatically.

SPRAY ADJUSTMENT

- Slowly turn clockwise the pressure control knob to reach the pressure value in order to ensure a good atomization of the product.
- An irregular and marked spray on the sides indicates a low working pressure. On the contrary, a too high pressure causes a high fog (“overspray”) and waste of product.
- In order to avoid overthickness of paint, let the gun advance sideways (*right-left*) when spraying.
- Always paint with regular parallel bands coats.
- Keep a safety and constant distance between the gun and the support to be painted and also keep yourselves perpendicular to it.



NEVER point the spray gun at yourselves or at other people. The contact with the casting can use serious injuries. In case of injuries caused by the gun casting, seek immediate medical advice specifying the type of the product injected.



The drain valve is a safety valve too. When working at the maximum pressure available, releasing the gun trigger sudden increases of pressure can occur. In this case, the drain valve opens automatically eliminating part of the product from the recirculating tube. Then it closes so as to go back to the first working conditions.

J CLEANING AT THE END WORK

- Reduce pressure to the minimum (*turn counterclockwise the pressure control knob (1)*).

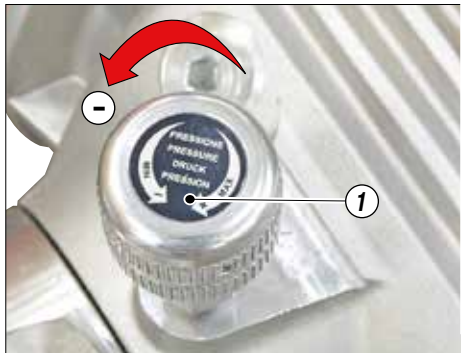

Fig. 1



Fig. 2

- Press the ON/OFF switch (2) placed on the box of the electric motor, to stop the equipment.
- First release the residual pressure from the gun by holding it pointed down towards the paint container, then open the re-circulation valve (3).

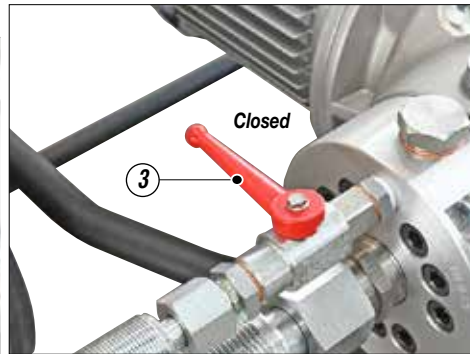
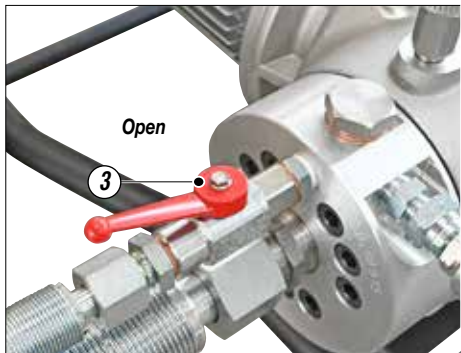

Fig. 3

- Lift the suction pipe and replace the product tank with that of the solvent (*ensure it is compatible with the product being used*).
- Unscrew the gun nozzle (*do not forget to clean it with solvent!*).
- Turn the ON-OFF switch (2) on the ON position and rotate the pressure setting knob (1) slightly clockwise.
- Make sure the solvent recycles the washing fluid from the return tube (4).
- Close the re-circulation valve (3).
- Point the gun at the product tank and, keeping the trigger pressed, release the remaining product till a clean solvent comes out. Now, release the trigger.
- Lift again the suction pipe and remove the solvent tank.
- Now point the gun at the solvent tank and press the trigger so as to recover the residual solvent.
- As the pump starts idling, press the ON/OFF switch to stop the equipment.
- In case of long storage, we recommend you to suck and to leave light mineral oil inside the pumping group and the flexible hose.



Follow the washing procedure before using again the equipment.

K ROUTINE MAINTENANCE

TOP UP HYDRAULIC OIL

With each start up, check the hydraulic oil level by looking through the gauge (1) on the side of the hydraulic body. If necessary, use to top up the level:

AGIP DICREA 150 type hidraulic oil



Fig. 1

RELEASE THE SUCTION VALVE

If the pump malfunctions, release the suction valve fitted on the head of the pump in the following way:

- Remove the suction hose fitting and release the valve by inserting a rigid rod (2) with a diameter of no more than 15 mm.

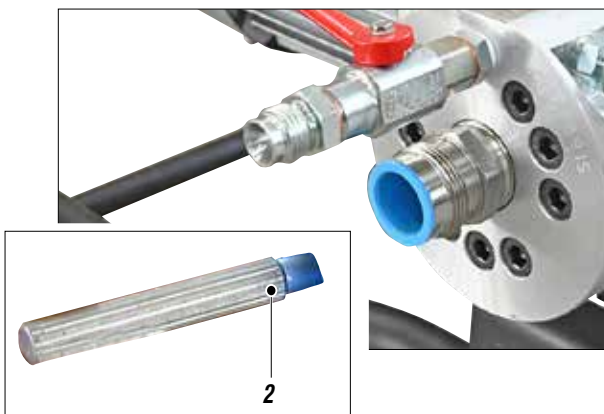

Fig. 2

CLEANING THE COMPRESSION VALVE

When the compression valve (3) must be removed, clean it with

specific solvents depending on the type of paint used and refit all parts by inverting the removal order.

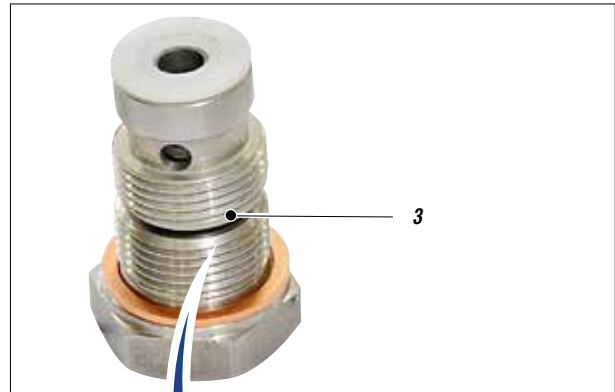

Fig. 3



Assemble the components in the correct order.

REPLACING HYDRAULIC OIL

After operating for 100 hours, replace the oil in the pump;

- Discharge the waste oil through the plug (4) fitted at the bottom of the pump casing.
- Clean the seals on the cap and replace it if worn.
- Remove and clean the filter (5) on the side of the pump casing; if necessary, replace the filter and the respective seals.
- Clean and, if necessary, replace the worn seals (5).
- Replace the plug (4).
- Fill the pump with the recommended oil until it reaches the maximum level (0,7 LT).

**AGIP DICREA 150 type hidraulic oil
0,7 LT**

- Then, substitute the oil every 250 hours.

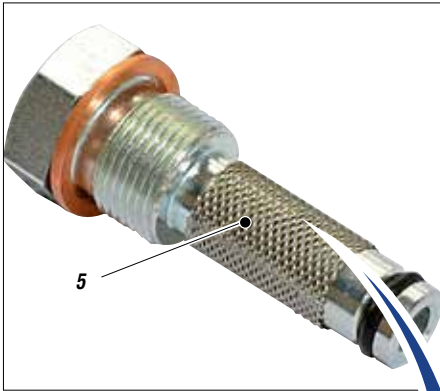

Fig. 5



Fig. 6



Fig. 7

CLEANING THE MOTOR COOLING FAN GUARD

Clean the motor cooling fan protection guard (K6) periodically to ensure the best cooling.

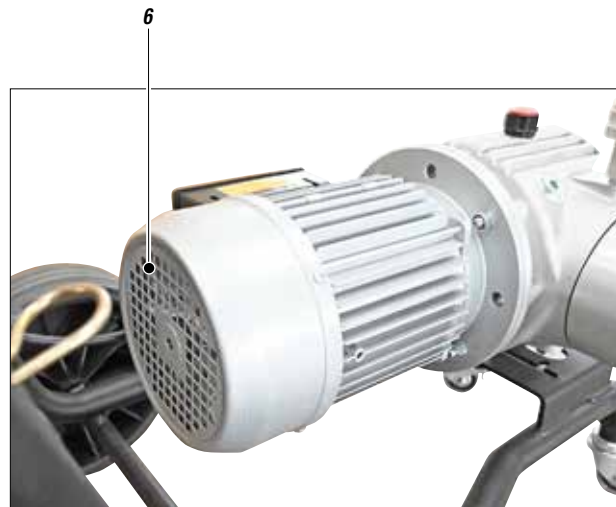

Fig. 8

L WARNING PLATE



Fig. 1

M CORRECT PROCEDURE OF DECOMPRESSION

- Insert the gun clamp (1).
- Move the ON/OFF switch (2) to the **OFF** position to stop the equipment.
- Set the valve (3) at its minimum pressure setting (*turn counterclockwise*).

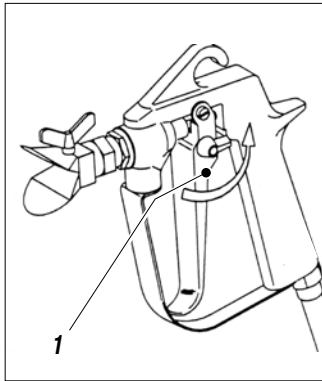

Fig. 1



Fig. 2



Fig. 3

- Disconnect the power supply cable (4).

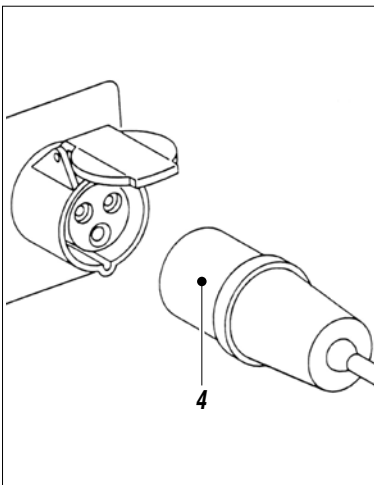

Fig. 4

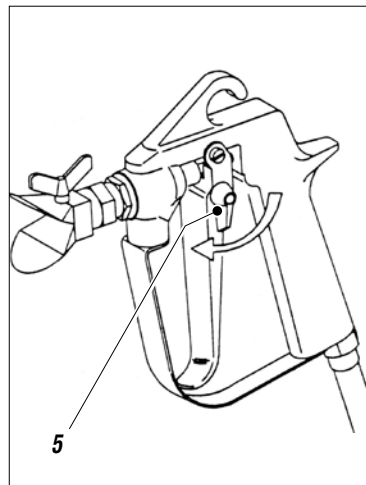

Fig. 5

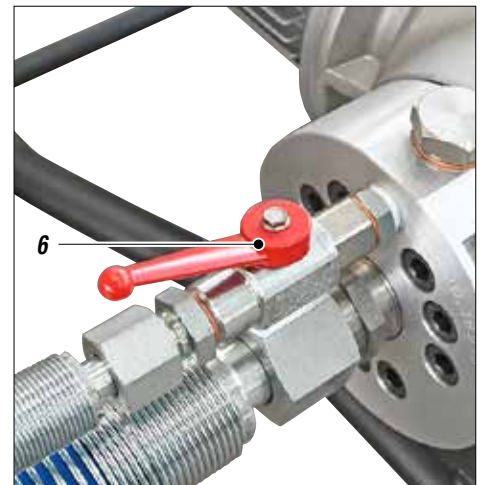

Fig. 6

- Release the gun clamp (5). Point the gun at the tank of the product and press the trigger to release pressure. At the end of the operation, insert the gun clamp.
- Open the re-circulation valve (6) to release residual pressure.



If the equipment is still under pressure after performing the operations above described because of the nozzle or the flexible hose clogged, proceed as follows:

- Loosen very slowly the gun nozzle.
- Release the clamp.
- Point the gun at the container of the product and press the trigger to release pressure.
- Loosen very slowly the fitting of connection from the flexible hose to the gun.
- Clean or replace the flexible hose and the nozzle.

N PROBLEMS AND SOLUTIONS

Problem	Cause	Solution
The equipment does not start	Lack of voltage;	Check the correct connection to the power supply;
	Considerable drops in mains voltage;	Check the extension cable;
	ON-OFF switch disconnected;	Ensure the ON-OFF switch is on the "ON" position and turn clockwise the pressure control knob;
	Setting valve faulty pressure;	Verify and replace it, if necessary;
	Breakdown of motor electric control box;	Verify and replace it, if necessary;
	The product is solidified inside the pump;	Open the drain valve to release pressure in the circuit and stop the machine. Remove the compression valve and clean it;
The equipment does not suck the product	Suction filter clogged;	Clean or replace it;
	Suction filter too fine;	Replace it with a larger-mesh filter (with very dense products, remove the filter);
	The equipment sucks air;	Check the suction pipe;
The equipment suck but does not reach the pressure desired	Lack of product;	Add the product;
	The equipment sucks air;	Check the suction pipe;
	The drain valve is open;	Close the drain valve;
	Suction or delivery valve dirty;	Disassemble the colour body group;
When pressing the trigger, the pressure lowers considerably	Nozzle too big or worn;	Replace it with a smaller one;
	The product is too dense;	Dilute the product, if possible;
	The filter of the gun-but is too fine;	Replace it with a larger-mesh filter;
The pressure is normal but the product is not atomized. Leakage from the seal-tightening screw	The nozzle is partially clogged;	Clean or replace it;
	The product is too dense;	Dilute the product, if possible;
	The filter of the gun-but is too fine;	Replace it with a larger-mesh filter;
The atomization is imperfect	The nozzle is worn;	Replace it;



Always close the air compressed supply and unload the plant pressure before performing any check or replacement of pump parts (see "correct procedure of decompression").

Intentionally blank page

0 COMPLETE HYDRAULIC BODY

WARNING: always indicate code and quantity for each part required.

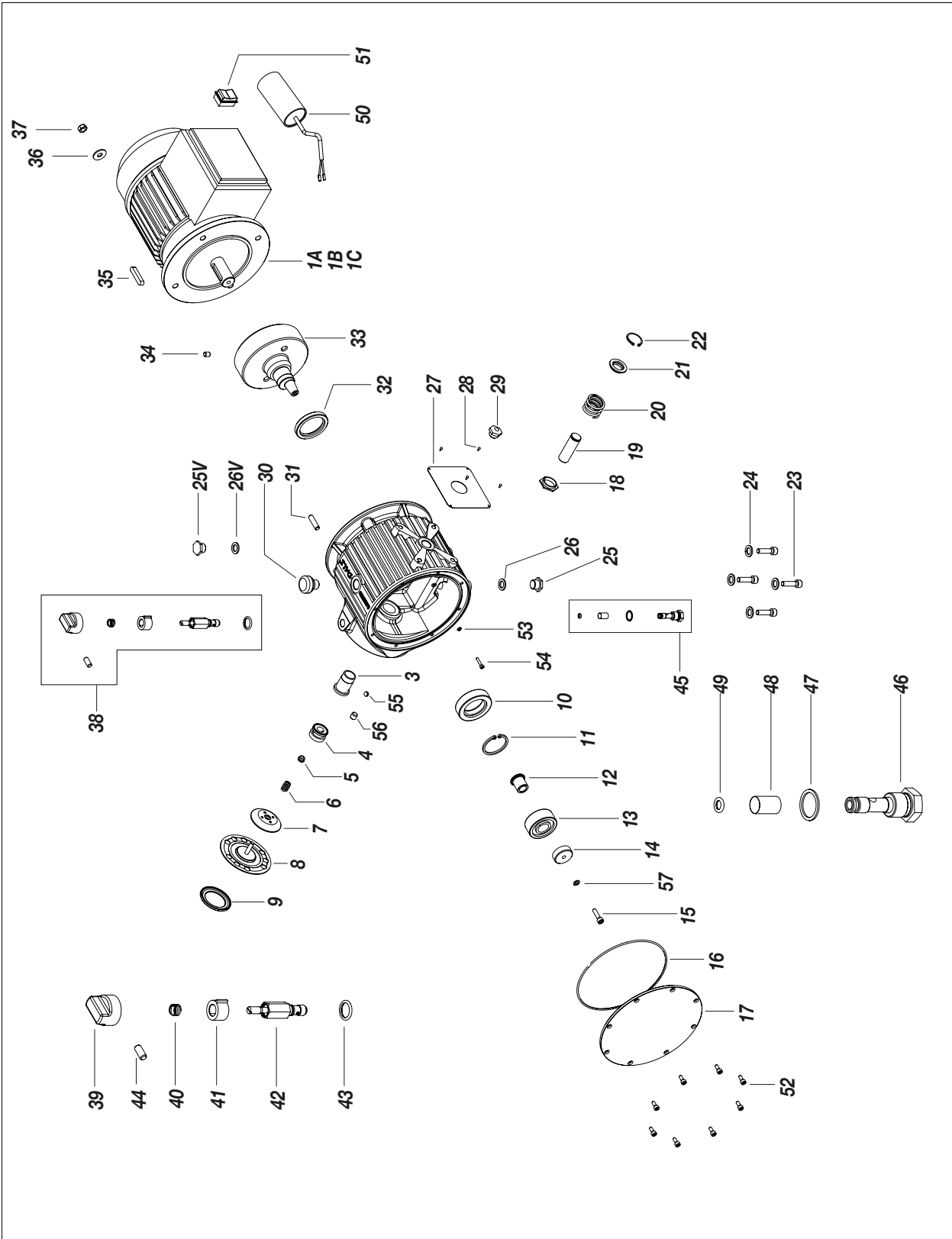

Fig. 1

Pos.	Code	Description
1A	18925	Electric motor mono-phase 220V 50Hz complete
1B	18926	Electric motor mono-phase 110V 60Hz complete
1C	18924	Electric motor three-phases 380V 50Hz complete
2	18901	Hydraulic body
3	32018	Cylinder liner
4	32033	Piston insert
5	33002/5	Nut
6	33002/3	Spring
7	18937	Oil distributor
8	33002/1	Diaphragm
9*	18936	Diaphragm insert
10	31125	Bearing
11	81020	Elastic ring
12	18906	Bushing
13	32026	Bearing
14	32027	Cover
15	32029	Screw
16	18908	OR
17	18907	Cover
18	32041	Check nut
19	32019	Piston
20	32022	Spring
21	32021	Spring cap
22	32020	Elastic ring
23	96031	Screw
24	32024	Washer
25	32108	Plug
25V*	32108	Plug
26	33010	Washer
26V*	33010	Washer
27	18910	Identification plate 220V 50Hz
27	18931	Identification plate 110V 60Hz

SPARES SUPPLIED COMPLETE (reccomended) - COD. 18952

Pos.	Description
2	Hydraulic body
3	Cylinder liner
10	Bearing
11	Elastic ring
18	Check nut

Pos.	Code	Description
27	18932	Petrol identification plate
27	18933	Identification plate 380V 50Hz
28	34020	Rivet
29	32007	Oil inspection window
30	32006	Plug
31	81012	Spline
32	18909/1	Corteco
33	18947	Eccentric flywheel
34	81009	Dowel
35	18919	Tab
36	33005	Washer
37	18903	Nut
38	32150	Complete pressure regulation valve
39	32017	Knob
40	32017/2	Spring
41	32016	Retainer
42	32155	Valve body
43	32014	OR
44	32017/1C	Dowel
45	12475	Oil filter assembly
46	12461	Filter
47	32010	Copper washer
48	258	Filter sieve 60 MESH
49	32012	OR
50	18928	Motor condenser 220V 50Hz
50	18929	Motor condenser 110V 60Hz
51	18938	Switch
52	32032	Screw
53*	5059	Washer
54*	18567	Screw
55*	91915	Ball
56	18946	Dowel
57	32028	Washer (Typ Grower)

COMPLETE MEMBRANE - COD. 18904

Pos.	Description
5	Nut
6	Spring
7	Oil distributor
8	Diaphragm

* Only in the vertical configuration

P PETROL ENGINE

WARNING: always indicate code and quantity for each part required.

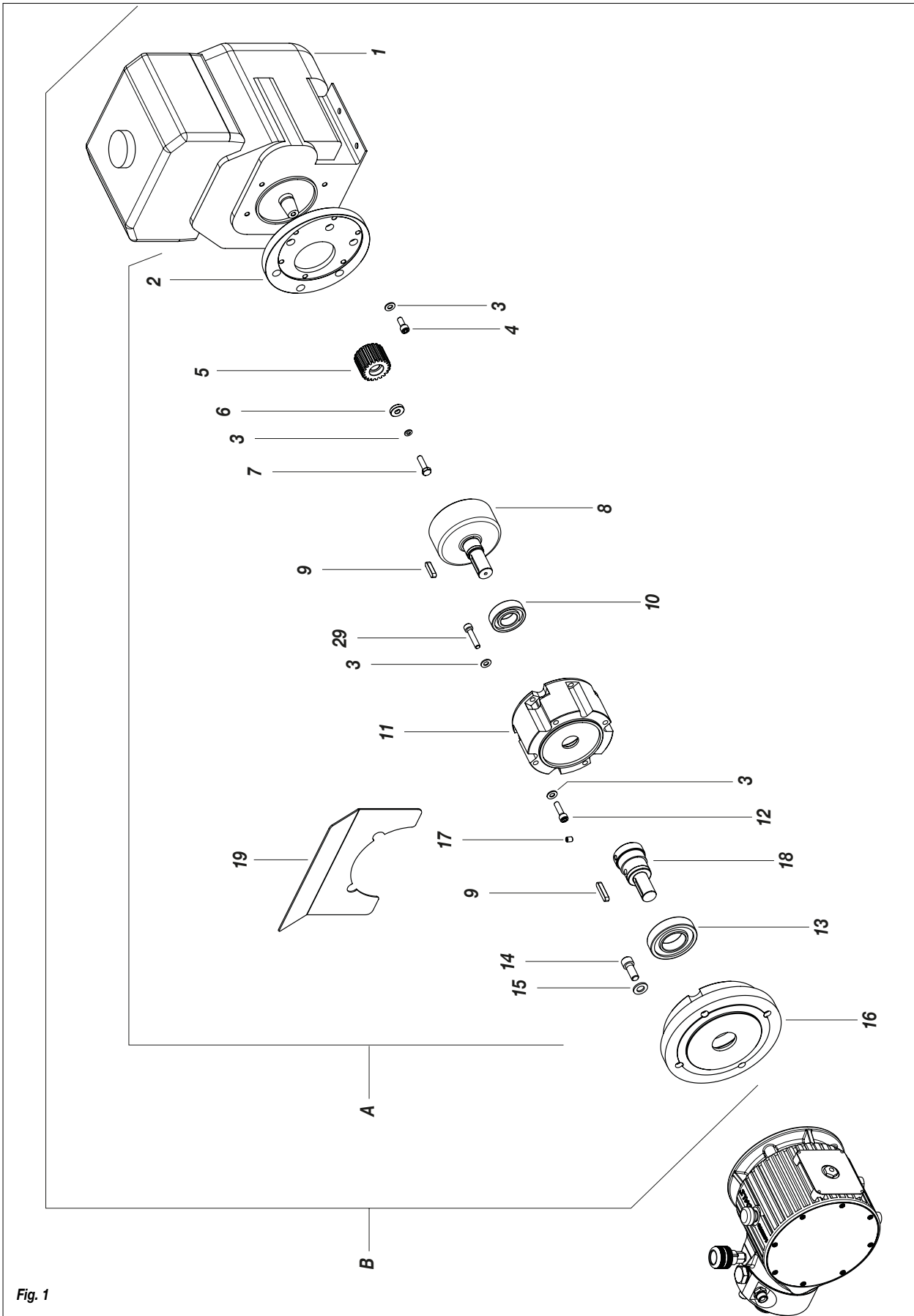

Fig. 1

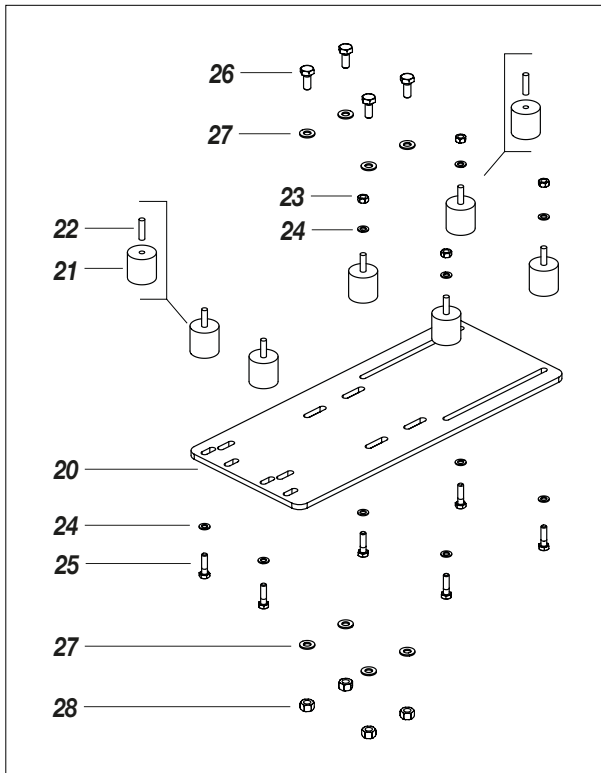

Fig. 2

C

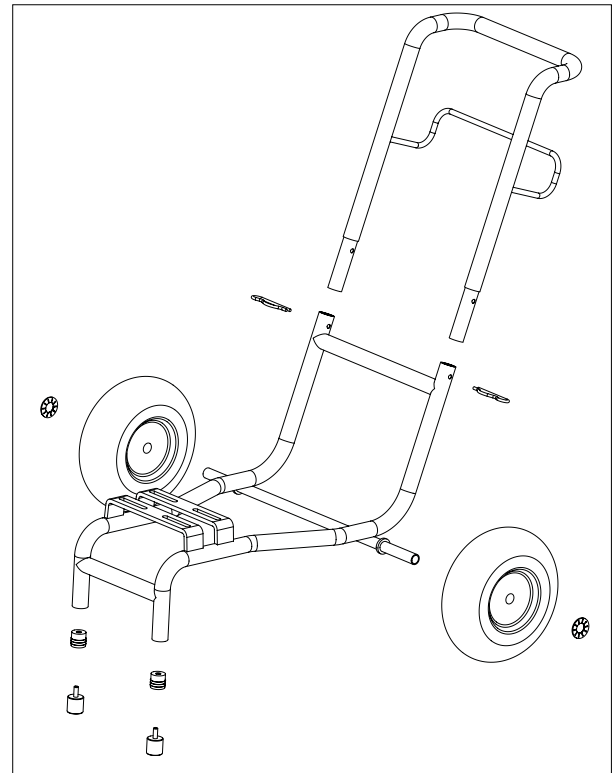

Fig. 3

D

Pos.	Code	Description
A	18260	Complete gearbox – petrol membrane version
B+C+D	18340	Complete gearbox kit – Dali petrol version with trolley
B+C	18347	Complete Dali liner kit
1	4415	Motor
2	18261	Flange motor
3	34009	Washer
4	96031	Screw
5	18262	Pinion
6	18263	Washer
7	8385	Screw
8	18265	Toothed bell
9	18919	Tab
10	42255	Bearing
11	18266	Gearbox cone
12	34008	Screw
13	18267	Bearing

Pos.	Code	Description
14	18344	Screw
15	95114	Washer
16	18268	Hydraulic flange
17	81009	Dowel
18	18269	Reduction
19	18264	Plating guard
20	18254	Fixing plate
21	81107	Vibration damper
22	18942	Threaded pin
23	96099	Nut
24	32024	Washer
25	34008	Screw
26	95156	Screw
27	81033	Washer
28	95158	Nut
29	7059	Screw

Q COMPLETE COLOUR BODY

WARNING: always indicate code and quantity for each part required.

VERTICAL VERSION

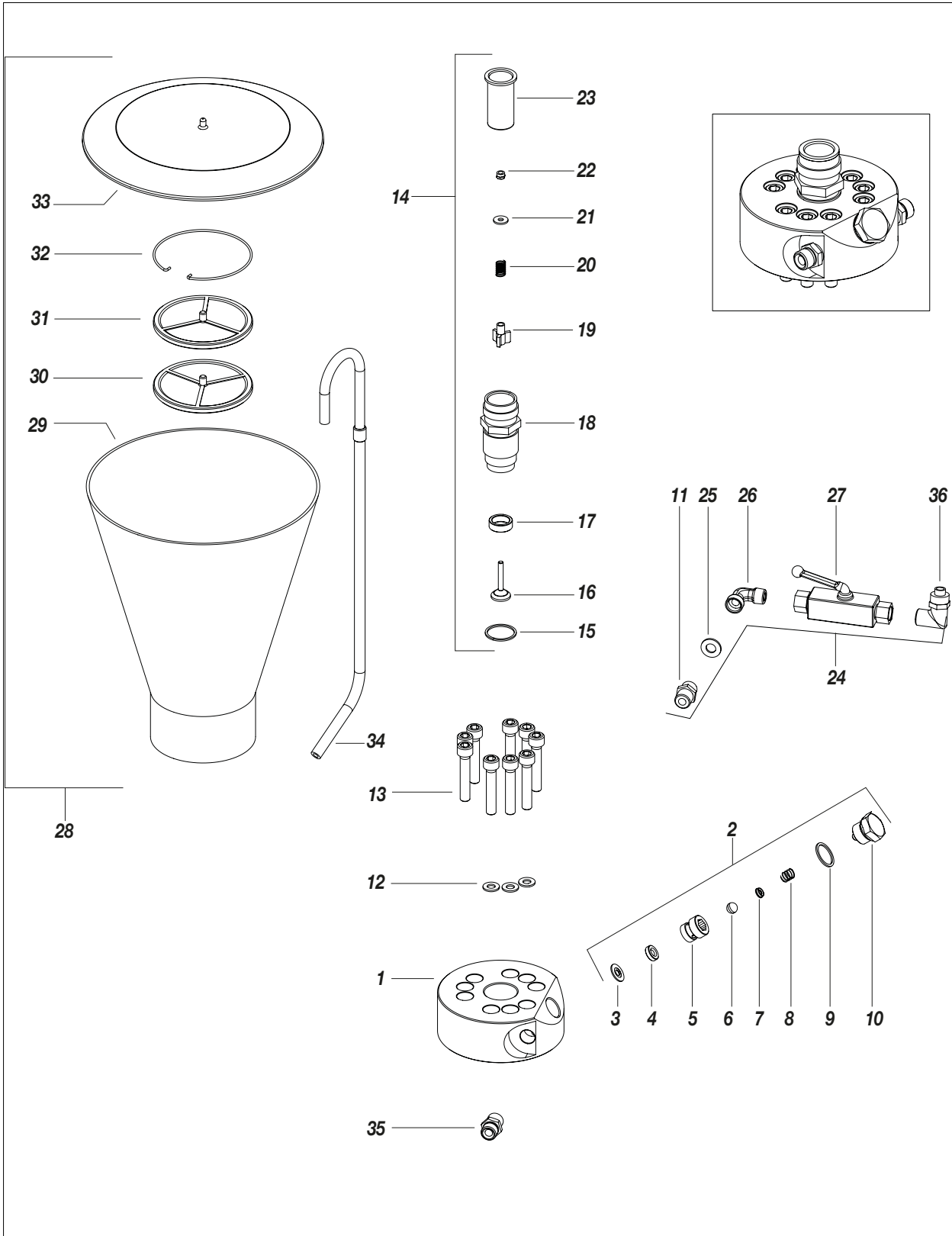

Fig. 1

Pos.	Code	Description
1	18951	Vertical colour body
2	83033	Valve assembly
3	33026	Gasket
4	33027/2	Ball seat
5	33027/1	Valve housing
6	33028	Ball
7	33029	Spring seat
8	53006/1	Spring
9	33031	Gas-ring
10	33032	Check nut
11	33011	Union
12	33005	Washer
13	33004	Screw
14	33017	Complete valve body
15	33018	Gas-ring
16	33019	Conical shutter
17	33020/1	Spear valve seat
18	33020	Valve body

Pos.	Code	Description
19	33021	Shutter guide
20	33022	Spring
21	33023	Washer
22	33024	Nut
23	96099	Seal sleeve
24	18922	Recirculation valve assembly
25	33012	Washer
26	18614	Elbow
27	33013	Cock
28	35101	Tank assembly
29	35103	Tank
30	35006	Close filter
31	35007	Large filter
32	35008	Spring ring
33	55000	Cover
34	18569	Recirculation tube
35	95284	Union
36	4011	Union

HORIZONTAL VERSION

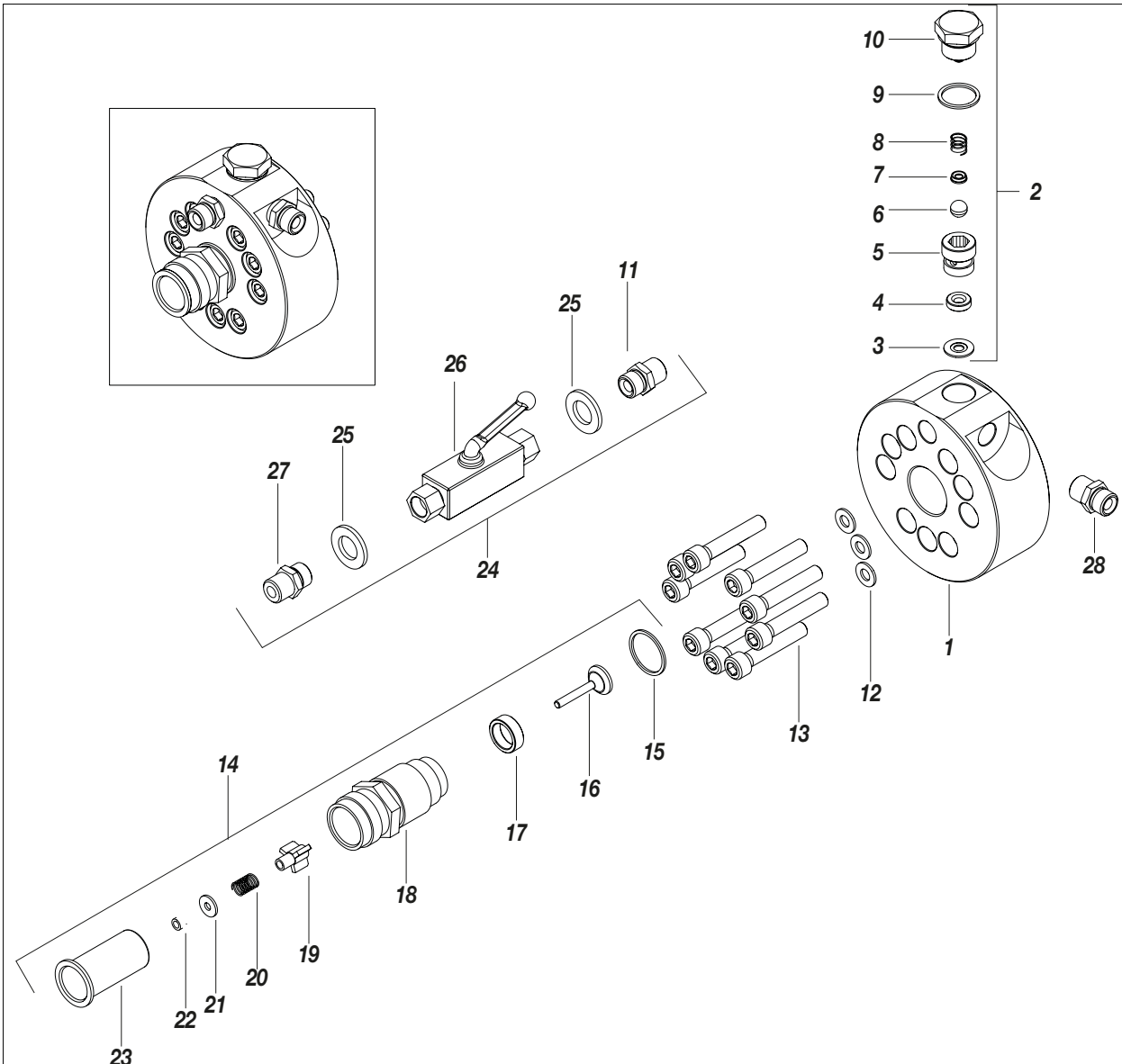

Fig. 2

Pos.	Code	Description
1	18915	Standard colour body
2	83033	Valve assembly
3	33026	Gasket
4	33027/2	Ball seat
5	33027/1	Valve housing
6	33028	Ball
7	33029	Spring seat
8	53006	Spring
9	33031	Gas-ring
10	33032	Plug
11	33011	Union
12	33005	Washer
13	33004	Screw
14	33017	Complete valve body

Pos.	Code	Description
15	33018	Gas-ring
16	33019	Conical shutter
17	33020/1	Spear valve seat
18	33020	Valve body
19	33021	Shutter guide
20	33022	Spring
21	33023	Washer
22	33024	Nut
23	33025	Seal sleeve
24	18922	Recirculation valve assembly
25	33012	Washer
26	33013	Cock
27	33015	Union
28	95284	Union

R SUCTION SYSTEM

WARNING: always indicate code and quantity for each part required.



Fig. 1

Pos.	Code	Description
-	85009	Suction systems
1	85010	Suction tube
2	16609	Recirculation tube
3	18096	Spring
4	85012	Filter of suction

S TROLLEY

WARNING: always indicate code and quantity for each part required.

ELECTRIC MOTOR

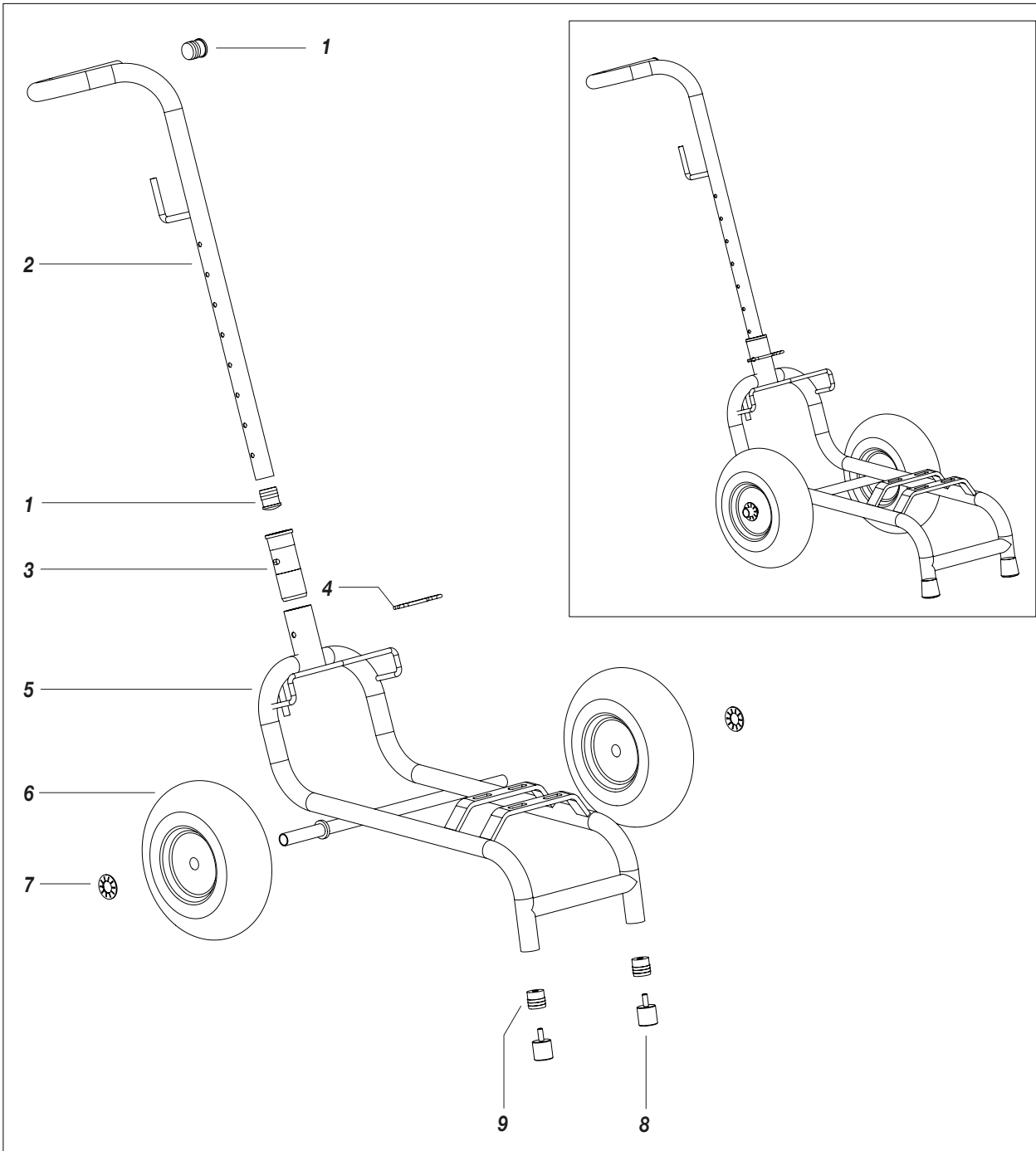

Fig. 1

Pos.	Code	Description
-	18911	Trolley assembly
1	95159	Plug
2	18912	Handle
3	18914	Bushing
4	18902	Split pin

Pos.	Code	Description
5	18913	Trolley frame
6	37218	Pneumatic wheel
7	91047	Washer
8	12454	Feet
9	12473	Plug

PETROL ENGINE

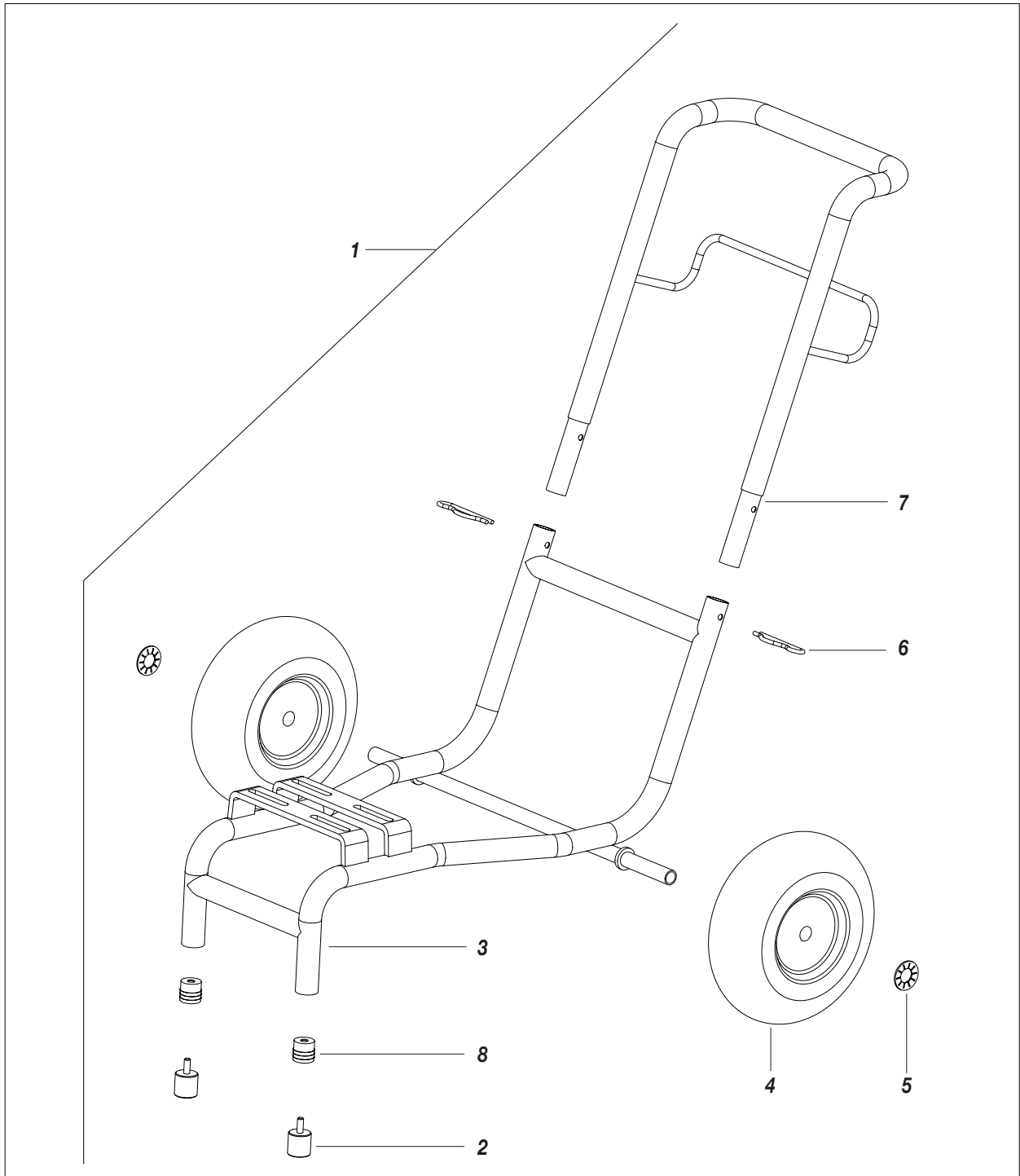

Fig. 2

Pos.	Code	Description
1	12355	Trolley assembly
2	12454	Foot
3	12710	Trolley base
4	37218	Pneumatic wheel
5	91047	Elastic washer

Pos.	Code	Description
6	84007	Split pin
7	12711	Trolley handle
8	12473	Plug

Intentionally blank page



CE DECLARATION OF CONFORMITY



Company



LARIUS srl
Via Antonio Stoppani 21 - 23801 Calolziocorte (LC) ITALY
Tel: +39 0341 621152
Fax: +39 0341 621243
E-mail: larius@larius.com

Declares under his owns responsibility that the product:

DALI' Electric diaphragm pump

complies with the directives:

- EC Directive 2006/42 Machinery Directive
- EU Directive 2014/30 Electromagnetic Compatibility (EMC)
- EU Directive 2014/35 Low Voltage (LVD)

furthermore to the
harmonized standards:

- UNI EN ISO 12100-1/-2
Machinery safety, basic concepts, general principles of design. Basic terminology, methodology. Technical principles.

This declaration relates exclusively to the product in the state in which it was placed on the market, and excludes components or modifications which are added or carried out subsequently by end user.

Calolziocorte, 31 May 2024
Location / Date

Signature

Pierangelo Castagna
Managing Director

**SAMOA INDUSTRIAL, S.A. - HEADQUARTERS
SPAIN AND EXPORT MARKETS**

POL. IND. PORCEYO, I-14 - CAMINO DEL FONTÁN, 831
E-33392 GIJÓN (ASTURIAS), SPAIN
TEL.: +34 985 381 488 - FAX: + 34 985 147 213

**SAMOA S.A.R.L.
FRANCE**

P.A.E.I. DU GIESSEN
3, RUE DE BRISCHBACH
67750 SCHERWILLER, FRANCE
TEL.: +33 3 88 82 79 62 - FAX: +33 3 88 82 77 88

**SAMOA ITALIA - LARIUS
ITALY**

VIA ANTONIO STOPPANI,21
23801 CALOLZIOCORTE (LC) ITALY
Tel.: +39 0341 621152 - Fax: + 39 0341 621242

SAMOA FLOWTECH GMBH

GERMANY, AUSTRIA, SWITZERLAND, THE NETHERLANDS AND GREECE
AM OBEREICHHOLZ 4
D - 97828 MARKTHEIDENFELD, GERMANY
TEL.: +49 9391 9826 0 - FAX: +49 9391 98 26 50

SAMOA LTD.

UNITED KINGDOM AND REP. OF IRELAND

ASTURIAS HOUSE - BARRS FOLD ROAD
WINGATES INDUSTRIAL PARK
WESTHOUGHTON, BL5 3XP, UK
TEL.: +44 1942 850600 - FAX: +44 1942 812160









SAMOA CORPORATION

USA AND CANADA
90 MONTICELLO ROAD
WEAVERVILLE, NC 28787, USA
TEL. +1 (828) 645-2290 - FAX: +1 (828) 658 0840



©Copyright, SAMOA INDUSTRIAL, S.A.
SAMOA Industrial, S.A. is an ISO 9001, ISO 14001 and ISO 45001 certified company.

 **Contact us today!**
Visit www.samoaindustrial.com for more information.

OPERATING AND MAINTENAINCE MANUAL AVAILABLE IN:		
	IT	https://www.larius.com/wp-content/uploads/DALI_I.pdf
	EN	https://www.larius.com/wp-content/uploads/DALI_UK.pdf
	DE	https://www.larius.com/wp-content/uploads/DALI_D.pdf
	FR	https://www.larius.com/wp-content/uploads/DALI_F.pdf
	ES	https://www.larius.com/wp-content/uploads/DALI_SP.pdf
	RU	https://www.larius.com/wp-content/uploads/DALI_RU-1.pdf
	PL	https://www.larius.com/wp-content/uploads/DALI_PL.pdf
	PR	https://www.larius.com/wp-content/uploads/DALI_P.pdf